

**Transportstyrelsens föreskrifter och allmänna råd
om transport av last på fartyg och terminaler som
anlöps av fartyg som lastar eller lossar fast
bulklast
(konsoliderad elektronisk utgåva)**

Innehåll

1 kap. Allmänna bestämmelser.....	1
Tillämpningsområde	1
Definitioner.....	1
Lastinformation.....	5
Stuvning och säkring av last	7
Lastsäkringsmanual	7
Bekämpningsmedel.....	9
Syreanalys och detektering av farliga gaser.....	9
2 kap. Säkring av last i lastbärare	10
3 kap. Lastning, lossning och stuvning av bulkfartyg.....	11
Undantag.....	12
Lämplighetskrav för fartyg	12
Lämplighetskrav för terminaler	12
Terminaloperatörens ansvar.....	12
Befälhavarens ansvar	12
Terminalrepresentantens ansvar.....	13
Förfarandet i samband med lastning och lossning	13
4 kap. Transport av fast bulklast	14
5 kap. Transport av spannmål.....	14
Ikraftträdande- och övergångsbestämmelser.....	15
Bilaga 1. Bestämning av verifierad bruttovikt (VGM) enligt metod 1 och metod 2.....	15
Bilaga 2. Guidelines for the preparation of the cargo securing manual	21
Bilaga 3. Code of safe practice for cargo stowage and securing	31
Bilaga 4. Code of safe practice for ships carrying timber deck cargoes	107
Bilaga 5. Safe stowage and securing of cargo units and other entities in ships other than cellular container ships.....	179
Bilaga 6. Elements to be taken into account when considering the safe stowage and securing of cargo units and vehicles in ships	181
Bilaga 7. Recommendations for entering enclosed spaces aboard ships	187
Bilaga 8. Guidelines for securing arrangements for the transport of road vehicles on ro-ro ships	199

Bilaga 9. Dimensionerande accelerationer för sjötransport från svensk hamn.....	209
Bilaga 10. Dimensionering av lastsäkringsarrangemang i lastbärare	211
Bilaga 11. Lämplighetskrav för bulkfartyg	217
Bilaga 12. Lämplighetskrav för terminaler	219
Bilaga 13. Uppgifter som ska finnas med i informationsbroschyr.....	221
Bilaga 14. Information som befälhavaren ska lämna till terminalen	223
Bilaga 15. Befälhavarens förpliktelser före och under lastning eller lossning	225
Bilaga 16. Information som terminalen ska lämna till befälhavaren	227
Bilaga 17. Terminalrepresentantens förpliktelser före och under lastning eller lossning.....	229
Bilaga 18. Lastnings- eller lossningsplan	231
Bilaga 19. Checklista fartyg/hamn för säkerheten vid lastning eller lossning av bulkfartyg.....	233
Bilaga 20. Riktlinjer vid ifyllande av checklista för fartyg-/hamnsäkerhet.....	235
Bilaga 21. Adoption of the international code for the safe carriage of grain in bulk.....	241

Transportstyrelsens föreskrifter och allmänna råd om transport av last på fartyg och terminaler som anlöps av fartyg som lastar eller lossar fast bulklast; (konsoliderad elektronisk utgåva)

TSFS 2010:174

Konsoliderad elektronisk
utgåva

SJÖFART

beslutade den 25 oktober 2010. Ändringar införda t.o.m. TSFS 2016:92.

Den konsoliderade elektroniska utgåvan kan innehålla fel. Observera därför att det alltid är den tryckta utgåvan som gäller.

1 kap. Allmänna bestämmelser

Tillämpningsområde

1 §¹ Om inte annat anges i varje kapitel gäller dessa föreskrifter

- fartyg som är sysselsatta med lasttransporter,
- last i lastbärare som är avsedd för sjötransport,
- terminaler i Sverige som anlöps av bulkfartyg,
- fartyg med en bruttodräktighet av minst 20, dock med undantag för bestämmelserna om transport av spannmål, vilka gäller alla fartyg oavsett storlek, och
- svenska fartyg oavsett resa och utländska fartyg som befinner sig inom Sveriges sjöterritorium.

Föreskrifterna gäller inte:

- vid utländska fartygs oskadliga genomfart av Sveriges sjöterritorium, eller
- transporter av flytande ämnen i bulk eller gaser i bulk.

För fartyg i inlandssjöfart gäller inte bestämmelserna i bilaga 5. IMO-resolutionen A.489(XII) i 12 § 3 utgör endast en rekommendation för fartyg i inlandssjöfart. (TSFS 2014:119)

Definitioner

2 § I dessa föreskrifter tillämpas följande definitioner, om inte annat särskilt anges:

¹ Motsvarar SOLAS regel VI/1.1.

<i>1974 års SOLAS-konvention</i>	den internationella konventionen om säkerheten för människoliv till sjöss samt därtill hörande protokoll och ändringar, i gällande version
<i>avlastare</i>	person som ingår ett godstransportavtal med en transportör eller i vars namn eller på vars vägnar ett sådant avtal ingås
<i>behörig myndighet</i>	en nationell, regional eller lokal myndighet i en medlemsstat, som enligt den nationella lagstiftningen har befogenhet att tillämpa och verkställa kraven i Europaparlamentets och rådets direktiv 2001/96/EG om fastställande av harmoniserade krav och förfaranden för säker lastning och lossning av bulkfartyg, senast ändrat genom Europaparlamentets och rådets direktiv 2002/84/EG
<i>BLU-koden</i>	koden för säker lastning och lossning av bulkfartyg ² antagen genom IMO-resolution A.862(20), ändrad genom IMO-resolution MSC.238(82) och MSC.304(87) (TSFS 2013:99)
<i>bulkfartyg</i>	<ul style="list-style-type: none">– ett fartyg som är byggt med enkelt däck, toppvingtankar och hoppertankar i lastrummen och som huvudsakligen är avsett att frakta fasta laster i bulk, eller– ett malmfartyg, dvs. ett fartyg med enkelt däck med två längsgående skott och dubbel botten i hela lastlådan, och som är avsett att frakta malm endast i de mellersta lastrummen, eller– ett kombinationsfartyg enligt definitionen i regel II-2/3.14 i 1974 års SOLAS-konvention

² Code of Practice for the Safe Loading and Unloading of Bulk Carriers.

<i>container</i>	<p>en transportanordning som är</p> <ol style="list-style-type: none"> 1. tillräckligt motståndskraftig för att medge upprepad användning, 2. konstruerad för att underlätta godstransporter med ett eller flera transportsätt utan att godset lastas om, 3. konstruerad för att lätt kunna förankras och hanteras och för de ändamålen försedd med en särskild anordning av öppningar och ytor, som är placerad på containerns över- eller undersida för att möjliggöra hantering, stapling eller förankring (hörmbeslag), och 4. så stor att den yta som omfattas av de fyra yttre bottenhörnen är antingen minst 14 m² (150 kvadratfot) eller, om containern är försedd med övre hörmbeslag, minst 7 m² (75 kvadratfot) (TSFS 2016:52)
<i>CSS-koden</i>	<p>koden för säker stuvning och säkring av last³, antagen genom IMO-resolution A.714(17), ändrad genom IMO-cirkulären MSC/Circ.664, MSC/Circ.691, MSC/Circ.740, MSC/Circ.812, MSC/Circ.1026 och MSC/Circ.1352 (TSFS 2013:99)</p>
<i>fartyg i inlandssjöfart</i>	<p>fartyg som har ett gemenskapscertifikat för inlandssjöfart i enlighet med Transportstyrelsens föreskrifter och allmänna råd (TSFS 2014:96) om tekniska krav för fartyg i inlandssjöfart (TSFS 2014:119)</p>
<i>fast bulklast</i>	<p>alla material, utom vätskor och gaser, som består av en kombination av partiklar, granulat eller större bitar av material, i allmänhet likformiga till sin sammansättning, som lastas direkt ner i fartygets lastutrymmen utan någon mellanliggande form av inneslutning</p>
<i>förstängning</i>	<p>(stämpling) metod att hindra last att glida och, om förstängningen sträcker sig tillräckligt högt upp, även att tippa</p>
<i>IMO</i>	<p>den internationella sjöfartsorganisationen (International Maritime Organization)</p>

³ Code of Safe Practice for Cargo Stowage and Securing.

<i>kort internationell resa</i>	resa under vilken <ul style="list-style-type: none"> – ett fartyg inte befinner sig längre än 200 nautiska mil från en hamn eller en plats där passagerarna och besättningen kan föras i säkerhet, – avståndet mellan hamnen där resan börjar och den slutliga destinationshamnen är maximalt 600 nautiska mil, – återresan är maximalt 600 nautiska mil, och – den slutliga destinationshamnen är den sista anlöpshamnen under den planerade resan, det vill säga den hamn där fartyget påbörjar återresan till den hamn där resan började (<i>TSFS 2016:52</i>)
<i>lastbärare</i>	fordon, vagnar, containrar, kassetter, transportlådor, transportbehållare eller motsvarande enheter avsedda för godstransport
<i>lastenhet</i>	två eller flera sammanhängande lastbärare eller ett fordon sammankopplat med lastbärare
<i>lastförskjutning</i>	förskjutning av lasten under transport av sådan omfattning att lastsäkringens försämras eller risk uppstår för skador på person, last, lastbärare eller fartyg
<i>lastinformation</i>	de upplysningar om lasten som krävs enligt 1 kap. 3 och 4 §§
<i>lastsäkring</i>	metoder att hålla kvar lasten i avsett läge under transport
<i>låsning</i>	mekaniskt fastgörande av last så att den hindras att glida och/eller tippa
<i>MBL</i>	lastsäkringsutrustningens brottstyrka ⁴
<i>MSL</i>	maximal tillåten belastning av lastsäkringsutrustningen ⁵
<i>paketgods</i>	gods samlat i mindre lastbärare, såsom kartonger eller lådor, fristående eller på öppen pall
<i>spannmål</i>	vete, råg, korn, havre, majs, ris, frön, baljfrukter och bearbetade former av dessa, vilkas beteende liknar spannmålets i dess naturliga form
<i>spannmålskoden</i>	den internationella spannmålskoden ⁶ , antagen genom IMO-resolution MSC.23(59)

⁴ Maximum Break Load.

⁵ Maximum Securing Load.

⁶ International Code for the Safe Carriage of Grain in Bulk.

<i>surmning</i>	metoder för att förhindra att last glider och/eller tippas
<i>terminal</i>	varje fast, flytande eller rörlig anläggning som är utrustad och används för att lasta eller lossa fasta bulklaster i eller ur bulkfartyg
<i>terminaloperatör</i>	ägaren av en terminal eller den fysiska eller juridiska person till vilken ägaren har överlämnat ansvaret för den lastning och lossning av ett enskilt bulkfartyg som utförs vid terminalen
<i>terminalrepresentant</i>	den person som utsetts av terminaloperatören att ha det övergripande ansvaret för och rätten att vid terminalen kontrollera lastningen eller lossningen av ett enskilt bulkfartyg
<i>timmerlastkoden</i>	2011 års kod för säkerheten vid transport av timmer som däckslast ⁷ , antagen genom IMO-resolution A.1048(27) med rättelse (TSFS 2013:99)
<i>transportköpare</i>	person som ingår ett godstransportavtal med en transportör eller i vars namn eller på vars vägnar ett sådant avtal ingås (TSFS 2013:99)
<i>verifierad bruttovikt (VGM)</i>	bruttovikten av en packad container bestämd genom tillämpning av någon av två metoder enligt bilaga 1 (TSFS 2013:99)

Lastinformation

3 §⁸ Befälhavaren ska kunna säkerställa att:

1. olika typer av last är kompatibla med varandra och tillräckligt separerade från varandra,
2. lasten är anpassad för fartyget,
3. lasten kan lastas, stuvats och säkras på ett erforderligt sätt, och
4. containrar som lastas ombord har en verifierad bruttovikt (VGM).

Befälhavaren ska därför i god tid före lastning se till att han har nödvändig information om lasten. För fartyg med en bruttodräktighet om 500 och däröver ska informationen framgå av ett formulär för lastinformation. Formuläret får vara i elektronisk form.

Kravet i första stycket 4 gäller inte containrar på nationell resa eller containrar på chassi eller trailer som körs på eller av ett ro-ro-fartyg på kort internationell resa. (TSFS 2016:52)

⁷ Code of Safe Practice for Ships carrying Timber Deck Cargoes, 2011 (2011 TDC Code).

⁸ Motsvarar SOLAS regel VI/1.2 och 2.1-2.

Allmänna råd

Formuläret om lastinformation kan ha det utseende som framgår av bilaga 1. Om någon annan typ av informationsbärare används ska den informationen omfatta åtminstone samma uppgifter som framgår av formuläret i bilaga 1.

Riktlinjer för vilka uppgifter som bör finnas med i lastinformationen finns för respektive last i CSS-koden, i timmerlastkoden samt i IMO-cirkulär MSC/Circ.525, MSC/Circ.548 och MSC/Circ.663 (TSFS 2016:52)

4 §⁹ Om styckegods eller last transporteras i lastbärare ska lastinformationen minst innehålla en allmän beskrivning av lasten, lastens eller lastbärarens totalvikt och övriga relevanta särskilda egenskaper som lasten har.

Om lastbäraren är en container som transporteras på fartyg i internationell trafik, undantaget containrar på chassi eller trailer som körs på eller av ett ro-ro-fartyg på kort internationell resa, ska lastinformationen även innehålla uppgifter om containerns verifierade bruttovikt (VGM) enligt bilaga 1. (TSFS 2016:52)

Allmänna råd

Beroende av lastens mängd och art bör information om lasten anges på det sätt som anges i 3 och 4 §§ även på fartyg med en bruttodräktighet under 500. (TSFS 2013:99)

5 §¹⁰ Befälhavaren ska före lastning försäkra sig om att bruttovikten hos de containrar som omfattas av kravet på uppgift om verifierad bruttovikt (VGM) i 4 § andra stycket överensstämmer med vad som är angivet i lastinformationen. Om lastinformationen för en container saknar uppgift om verifierad bruttovikt får den inte lastas på fartyg.

För övriga lastenheter ska befälhavaren, om så är praktiskt möjligt, före lastning försäkra sig om att deras bruttovikt överensstämmer med den vikt som finns angiven i transportdokumentationen. (TSFS 2016:52)

Allmänna råd

Skyldigheten i 5 § första stycket kan uppfyllas antingen genom kontrollvägning eller genom kontroll av dokumentation eller andra uppgifter från transportköparen som styrker att uppgift lämnad i lastinformationen är tillförlitlig. Transportköparen kan exempelvis visa att företaget omfattas av ett kvalitetsledningssystem där process för vägning ingår. (TSFS 2016:52)

⁹ Motsvarar SOLAS regel VI/2.2.

¹⁰ Motsvarar SOLAS regel VI/2.3.

Stuvning och säkring av last

6 §¹¹ Fartyg ska vara lastade och barlastade så att fartygets sjövärdighet bibehålls under hela transporten. Last som förs på eller under däck ska lastas, stuvvas och säkras så att

- fartygets stabilitet eller strukturella styrka inte äventyras,
- lasten inte förskjuts under transporten, och
- säkerheten för fartyget eller de ombordvarande inte äventyras på annat sätt.

7 § För alla typer av last gäller följande: surrningsdon, låsningsdon, förstängningsdon och andra säkringsanordningar ska, vad gäller antal, styrka och elasticitet, dimensioneras så att

- arrangemangen kan ta upp de krafter som uppstår till följd av de dimensionerande accelerationerna, och
- lasten inte förskjuter sig.

Endast funktionsduglig utrustning med erforderlig styrka får användas för säkring av last ombord på fartyg och i lastbärare.

Den säkerhetsnivå som framgår av dessa föreskrifter kan behöva höjas, om extraordinära förhållanden så kräver. (TSFS 2013:99)

Allmänna råd¹²

Surningsutrustning och luftkuddar för säkring av last bör vara märkt med antingen MSL eller MBL. Undantag kan medges för märkning av ändlös surrningsutrustning om märkning inte låter sig göras på grund av surrningsutrustningens art. Saknar utrustningen märkning av MSL kan MSL för olika typer av utrustning beräknas enligt bilaga 10.

8 §¹³ En container får efter lastning inte väga mer än den högsta tillåtna bruttovikten, vilken enligt 6 § containerlagen (1980:152) ska finnas angiven på containerns säkerhetsskylt.

Lastsäkringsmanual

9 §¹⁴ Fartyg ska vara utrustade med en för fartyget individuell lastsäkringsmanual. Manualen ska vara godkänd av fartygets flaggstats-administration och hållas uppdaterad. För svenska fartyg gäller att lastsäkringsmanualen och ändringar av den ska ges in till Transportstyrelsen för godkännande.

För fartyg som transporterar fasta bulklaster eller fartyg som används endast i fartområde E eller zon 3 och 4 gäller inte vad som sägs i första stycket. Fartområdet finns definierat i 1 kap. 3 § fartygssäkerhetsförord-

¹¹ Motsvarar SOLAS regel VI/5.1–2.

¹² Ändringen innebär att sista stycket har upphävts.

¹³ Motsvarar SOLAS regel VI/5.5.

¹⁴ Motsvarar SOLAS regel VI/5.6.

ningen (2003:438). Bestämmelser om zoner finns i 1 kap. Transportstyrelsens föreskrifter och allmänna råd (TSFS 2014:96) om tekniska krav för fartyg i inlandssjöfart.

För utländska fartyg med en bruttodräktighet under 500 gäller vad som sägs i första stycket endast om fartygets flaggstatsadministration inte har beslutat annat. (TSFS 2014:119)

10 §¹⁵ Lastsäkringsmanualen ska innehålla anvisningar för stuvning och säkring av last i enlighet med bestämmelserna i IMO-cirkulär MSC/Circ.1353, med undantag för vad som gäller enligt 11 §. Den arabiska, engelska, franska, kinesiska, ryska och spanska texten av cirkuläret ska ha samma giltighet¹⁶. Cirkuläret finns på engelska i bilaga 2 till dessa föreskrifter. (TSFS 2013:99)

11 § För fartyg på nationell resa med en bruttodräktighet under 500 kan Transportstyrelsen, under förutsättning att det är lämpligt med avseende på lastens och fartygets beskaffenhet, efter ansökan medge att fartyget förses med en lastsäkringsmanual med förenklat innehåll.

Lastsäkringsmanualen med förenklat innehåll och ändringar ska ges in till Transportstyrelsen för godkännande.

En lastsäkringsmanual med förenklat innehåll ska omfatta minst följande avsnitt:

- en lista över lastsäkringsutrustning och dess antal som finns ombord inklusive beskrivning, handhavandeinstruktioner, och utrustningens MSL,
- exempel på hur lasten ska säkras, samt beräkningsgrunder och kriterier för dimensioneringen,
- en plan över surrningspunkter, och
- rutiner för kontroll av utrustningens skick och utsortering av utrustning som inte är funktionsduglig enligt 7 §.

12 §¹⁷ Vid upprättande av lastsäkringsmanualer för svenska fartyg ska, med undantag för vad som gäller enligt 13 §, beroende av lastens och fartygets beskaffenhet, bestämmelserna i punkt 1–3 nedan följas:

1. CSS-koden,
2. timmerlastkoden, och
3. IMO-resolutionerna A.489(XII), A.533(13) och A.581(14), ändrad genom MSC/Circ.812.

En annan metod, än de som anges i 1–3, som säkerställer en likvärdig eller högre säkerhetsnivå kan godtas efter beslut från Transportstyrelsen.

Den arabiska, engelska, franska, kinesiska, ryska och spanska texten av koderna och resolutionerna ska ha samma giltighet. **Fel! Bokmärket är inte definierat.** CSS-koden, timmerlastkoden och ovannämnda IMO-resolutioner finns på engelska i bilaga 3–8 till dessa föreskrifter.

¹⁵ Motsvarar SOLAS regel VI/5.6.

¹⁶ Texterna på arabiska, franska, kinesiska, ryska och spanska finns tillgängliga hos IMO.

¹⁷ Motsvarar SOLAS regel VI/1.2 och 5.1-2.

Vid tillämpning av annex 13 i CSS-koden får de framräknade accelerationerna (a) reduceras i farvatten med begränsade signifikanta våghöjder (HS) i meter enligt nedanstående formel där a_R avser de reducerade accelerationerna:

$$a_R = a \cdot \left(\frac{H_s}{19,6} \right)^{\frac{1}{3}}$$

13 § Vid upprättande av lastsäkringsmanualer med förenklat innehåll enligt 11 § behöver inte bestämmelserna i 12 § tillämpas. I stället får lastsäkringsarrangemanget dimensioneras enligt 2 kap. 5 § beroende på lastens och fartygets beskaffenhet.

14 § Lasten ska stuvras och säkras i enlighet med anvisningarna i lastsäkringsmanualen.

15 § Transportstyrelsen kan medge undantag från kravet på lastsäkringsmanual för svenska fartyg, om det är skäligt med hänsyn till fartygets begränsade användningsområde eller annan särskild omständighet.

Bekämpningsmedel

16 §¹⁸ Vid användande av bekämpningsmedel i lastutrymmen ska erforderliga försiktighetsåtgärder vidtas.

Allmänna råd

Då bekämpningsmedel används för att rengöra lastutrymmen bör riktlinjerna i "IMO Recommendations on the safe use of pesticides in ships" följas.

Syreanalys och detektering av farliga gaser

17 §¹⁹ Då fartyg transporterar fast bulklast som kan avge farliga gaser eller orsaka syrebrist i lastrummet, ska det finnas instrument som med nödvändig noggrannhet kan mäta syrehalten och upptäcka farliga gaser ombord. Instrument ska medföras tillsammans med en detaljerad bruksanvisning.

Instrument som finns ombord på svenska fartyg ska uppfylla kraven i lagen (2016:768) om marin utrustning och i föreskrifter meddelade i anslutning till lagen.

Besättningsmedlemmarna ska ha god kunskap om hur instrumenten används.

Bestämmelserna ovan gäller inte utländska fartyg med en brutto-dräktighet under 500, om fartygets flaggstatsadministration har godkänt någon annan metod för att uppnå erforderlig säkerhetsnivå. (TSFS 2016:92)

¹⁸ Motsvarar SOLAS regel VI/4.

¹⁹ Motsvarar SOLAS regel VI/3.

Allmänna råd

All personal som hanterar fast bulklast som kan avge farliga gaser eller orsaka syrebrist bör ha ett instrument för att mäta syrehalten. Syrehalten bör vara 20,9% för att undvika halter av andra farliga gaser som kan orsaka en ohälsosam atmosfär, vilket framgår av bilaga 7.

Kolmonoxid, koldioxid och svavelväte är vanligen förekommande gaser som kan vara farliga och som därför bör kunna mätas.

2 kap. Säkring av last i lastbärare

1 §²⁰ Detta kapitel gäller fartyg som transporterar last i lastbärare och last i lastbärare som är avsedd för sjötransport. För utländska fartyg gäller bestämmelserna vid transport från svensk hamn. Transport av paketgods som ska befordras på fartyg i fartområde E eller zon 3 och 4, eller gods som ska befordras med vägfärja i trafik på ordinarie färjeled omfattas inte av bestämmelserna i detta kapitel. Fartområdet finns definierat i 1 kap. 3 § fartygssäkerhetsförordningen (2003:438). Bestämmelser om zoner finns i 1 kap. Transportstyrelsens föreskrifter och allmänna råd (TSFS 2014:96) om tekniska krav för fartyg i inlandssjöfart. (TSFS 2014:119)

2 § Gods som transporteras med vägfärja i trafik på ordinarie färjeled omfattas av bestämmelserna i Trafiksäkerhetsverkets föreskrifter (TSVFS 1978:10) om säkring av last på fordon under färd.

3 § Transportstyrelsen kan medge undantag från tillämpning av bestämmelserna i detta kapitel, om det finns särskilda skäl.

4 § Last i lastbärare ska vara säkrad genom låsning, förstängning eller surring, genom en kombination av dessa lastsäkringsmetoder eller genom annan metod i den omfattning som krävs för att förhindra lastförskjutning.

5 § Lastsäkringsarrangemang för säkring av last i lastbärare ska dimensioneras i enlighet med de accelerationer som framgår av bilaga 9, samt de friktionskoefficienter och säkerhetsfaktorer som framgår av bilaga 10 till dessa föreskrifter. Transportstyrelsen kan efter enskilt beslut godta lastsäkringsarrangemang verifierade med praktiska prov enligt bilaga 10.

Allmänna råd

Lastsäkringsarrangemang bör anordnas i enlighet med någon av punkterna 1–3 nedan. Detta gäller under förutsättning att inget däri strider mot vad som framgår av dessa föreskrifter.

1. MSC/Circ.787 - IMO/ILO/UN ECE "Guidelines for packing of cargo transport units (CTUs)",

²⁰ Motsvarar SOLAS regel VI/5.2.

2. IMO working book "Safe packing of cargo transport units", avsnittet "Quick lashing guidelines for transportation on road and sea in areas A, B & C" (2001), eller

3. Transportfackens Yrkes- och Arbetsmiljönämnds lathundar, utgåvor daterade 2008-03-18,

– "Lastsäkring i lastbärare för transport i sjöfartsområde A",

– "Lastsäkring i lastbärare för transport i sjöfartsområde B",

– "Lastsäkring i lastbärare för transport i sjöfartsområde C".

Lastbärare som transporteras från svensk hamn bör medföra ett lastsäkringsintyg från den som utfört lastningen med försäkran om att lasten är säkrad i enlighet med dessa föreskrifter. Ett sådant intyg bör även utvisa beräkningar samt annan relevant dokumentation som ligger till grund för dimensioneringen av lastsäkringsarrangemanget.

6 § Vid förstängning får måttet av fritt utrymme mellan godsenheter inbördes och mellan godsenheter och sidolem eller sidovägg sammanlagt uppgå till maximalt 15 cm. Samma mått gäller för motsvarande förstängning i längdled. Vid förstängning av tungt stumt gods ska fritt utrymme minimeras.

3 kap. Lastning, lossning och stuvning av bulkfartyg²¹

1 §²² Detta kapitel gäller bulkfartyg oavsett storlek, samt andra fartyg med en bruttodräktighet om 500 och däröver, vilka transporterar fast bulklast och vilka anlöper en terminal för att lasta eller lossa fasta bulkklaster, oavsett vilken flagg fartyget för. Kapitlet gäller dessutom alla terminaler som anlöps av sådana bulkfartyg.

2 § Grundläggande bestämmelser finns i lagen (2003:367) om lastning och lossning av bulkfartyg.

Allmänna råd

Vid lastning och lossning av fasta bulkklaster bör bestämmelserna i BLU-koden och IMO-cirkulär MSC/Circ.1160, senast ändrat genom IMO-cirkulär MSC/Circ.1230 och MSC/Circ.1356, följas. I tillägg till BLU-koden bör även MSC/Circ.1357 beaktas.

(TSFS 2013:99)

²¹ Motsvarar delvis Europaparlamentets och rådets direktiv 2001/96/EG om fastställande av harmoniserade krav och förfaranden för säker lastning och lossning av bulkfartyg, senast ändrat genom Europaparlamentets och rådets direktiv 2002/84/EG.

²² Motsvarar direktiv 2001/96/EG art. 2 och SOLAS regel VI/del B.

Undantag

3 § Detta kapitel ska inte tillämpas på fartyg som transporterar spannmål eller på terminaler som endast i undantagsfall används för lastning och lossning av fasta bulkklaster.

4 §²³ För nyligen inrättade terminaler kan som ett undantag från kravet om kvalitetssäkringssystem i 6 § 5 lagen (2003:367) om lastning och lossning av bulkfartyg, medges ett temporärt tillstånd, med högst tolv månaders giltighet, att bedriva lastning och lossning av bulkfartyg. Terminalen måste emellertid visa att den har en plan för genomförande av ett system.

Lämplighetskrav för fartyg

5 §²⁴ Fartyg ska, för att anses lämpliga för lastning och lossning av fasta bulkklaster, uppfylla de krav som anges i bilaga 11.

Lämplighetskrav för terminaler

6 §²⁵ Terminaler ska, för att anses lämpliga för lastning och lossning av fasta bulkklaster, uppfylla de krav som anges i bilaga 12.

Terminaloperatörens ansvar

7 §²⁶ Den informationsbroschyr som terminaloperatören ansvarar för enligt 6 § 4 lagen (2003:367) om lastning och lossning av bulkfartyg, ska innehålla de tillämpliga upplysningar om hamnen och terminalen som anges i bilaga 13.

8 § Det kvalitetssäkringssystem som terminaloperatören ansvarar för enligt 6 § 5 lagen (2003:367) om lastning och lossning av bulkfartyg ska vara certifierat enligt ISO-standard 9001:2000 eller likvärdig standard som ställer minst samma krav och kontrolleras enligt riktlinjerna i ISO-standard 10011:1991 eller likvärdig standard, som ställer samma krav.

Befälhavarens ansvar

9 §²⁷ Den information som befälhavaren ska lämna enligt 7 § 2 lagen (2003:367) om lastning och lossning av bulkfartyg framgår av bilaga 14.

10 § Den information befälhavaren ska få, enligt 7 § 3 lagen (2003:367) om lastning och lossning av bulkfartyg, ska anges på ett formulär för last-

²³ Motsvarar direktiv 2001/96/EG art. 6.

²⁴ Motsvarar direktiv 2001/96/EG art. 4.

²⁵ Motsvarar direktiv 2001/96/EG art. 5.

²⁶ Motsvarar direktiv 2001/96/EG art. 7.2.

²⁷ Motsvarar direktiv 2001/96/EG art. 7.1.

information enligt sektion 4 i bilaga 1 till Transportstyrelsens föreskrifter (TSFS 2010:166) om transport till sjöss av fast gods i bulk (IMSBC-koden). (TSFS 2013:99)

11 §¹⁹ Befälhavaren ska, innan lasthantering påbörjas samt under lastning och lossning, fullgöra de förpliktelser som framgår av bilaga 15.

Terminalrepresentantens ansvar

12 §²⁸ Terminalrepresentanten ska, när terminalen tar emot fartygets första anmälan om beräknad ankomsttid, se till att befälhavaren får de upplysningar som framgår av bilaga 16.

13 §²⁹ Terminalrepresentanten ska försäkra sig om att befälhavaren så tidigt som möjligt har blivit underrättad om innehållet i lastinformationen.

14 §³⁰ Innan lasthanteringen påbörjas samt under lastning eller lossning ska terminalrepresentanten fullgöra de förpliktelser som framgår av bilaga 17.

Förfarandet i samband med lastning och lossning

15 §³¹ En lastnings- och lossningsplan ska innehålla IMO-numret på det berörda fartyget och undertecknas av befälhavaren och terminalrepresentanten.

Planen ska utarbetas i den form som framgår av bilaga 18. Varje ändring av planen, som enligt någon av parterna kan beröra fartygets eller besättningens säkerhet, ska utarbetas och godkännas av bägge parterna i form av en reviderad plan.

16 §³² Den överenskomna lastnings- eller lossningsplanen och varje överenskommen revidering av denna ska hållas tillgänglig på terminalen under tre år för kontroll av behöriga myndigheter.

17 §³³ Innan lastning eller lossning påbörjas ska checklistan för säkerheten i gränssnittet mellan fartyg och hamn, bilaga 19, gemensamt fyllas i och undertecknas av befälhavaren och terminalrepresentanten enligt riktlinjerna i bilaga 20.

18 §³⁴ Kommunikation ska finnas mellan fartyget och terminalen under hela lasthanteringsprocessen
– för utbyte av information, och

²⁸ Motsvarar direktiv 2001/96/EG art. 7.2(a).

²⁹ Motsvarar direktiv 2001/96/EG art. 7.2(b).

³⁰ Motsvarar direktiv 2001/96/EG art. 7.2(d).

³¹ Motsvarar direktiv 2001/96/EG art. 8.1.

³² Motsvarar direktiv 2001/96/EG art. 8.1.

³³ Motsvarar direktiv 2001/96/EG art. 8.2.

³⁴ Motsvarar direktiv 2001/96/EG art. 8.3.

– för att lastning eller lossning på befälhavarens eller terminalrepresentantens order omedelbart ska kunna stoppas.

19 §³⁵ Befälhavaren och terminalrepresentanten ska genomföra lastning eller lossning enligt den överenskomna lastnings- eller lossningsplanen. Terminalrepresentanten ska ansvara för att lastning eller lossning sker i enlighet med den lastrumsordning, kvantitet och lastnings- eller lossningstakt som anges i planen.

Terminalrepresentanten får inte frångå den överenskomna planen utan att sådan ändring i form av en reviderad plan har godkänts av bägge parter.

20 §³⁶ När lastning eller lossning har avslutats ska befälhavaren och terminalrepresentanten skriftligen bekräfta att lastning eller lossning har utförts enligt planen, inklusive varje överenskommen ändring av denna.

När det gäller lossning ska denna bekräftelse också inbegripa

– ett protokoll som anger att lastrummen har tömts och rengjorts på det sätt som befälhavaren kräver,

– uppgift om eventuella skador på fartyget, samt

– eventuella reparationer som utförts.

4 kap. Transport av fast bulklast

1 §³⁷ Transport av fast bulklast annan än spannmål, ska uppfylla kraven i Transportstyrelsens föreskrifter (TSFS 2010:166) om transport till sjöss av fast gods i bulk (IMSBC-koden).

5 kap. Transport av spannmål

1 §³⁸ Detta kapitel omfattar svenska fartyg som transporterar spannmål och utländska fartyg som transporterar spannmål inom Sveriges sjöterritorium, oavsett storlek.

2 §³⁹ Fartyg som transporterar spannmål som last ska tillämpa bestämmelserna som finns i spannmålskoden. Den engelska, arabiska, kinesiska, franska, ryska och spanska texten av spannmålskoden ska ha samma giltighet. Koden finns på engelska i bilaga 21 till dessa föreskrifter.

3 §⁴⁰ Fartyg ska ha ett spannmålsintyg (Document of Authorization) i enlighet med spannmålskoden. Fartyg som saknar ett sådant intyg får inte lastas förrän Transportstyrelsen eller behörig myndighet i lastningslandet godkänt att fartyget kan antas uppfylla spannmålskoden i lastat skick.

³⁵ Motsvarar direktiv 2001/96/EG art. 8.4.

³⁶ Motsvarar direktiv 2001/96/EG art. 8.5.

³⁷ Motsvarar SOLAS regel VI/1-2.

³⁸ Motsvarar SOLAS regel VI/9.

³⁹ Motsvarar SOLAS regel VI/9.

⁴⁰ Motsvarar SOLAS regel VI/9.1-2.

Ikraftträdande- och övergångsbestämmelser

TSFS 2010:174

1. Denna författning träder i kraft den 1 januari 2011.
2. Sjöfartsverkets beslut som gäller då denna författning träder i kraft gäller även efter ikraftträdandet av denna författning. Sådana beslut ska anses ha meddelats av Transportstyrelsens och gäller till dess att Transportstyrelsen meddelar ett nytt beslut eller giltighetstiden för beslutet går ut.
3. Om det i en föreskrift som har beslutats av Sjöfartsverket hänvisas till Sjöfartsverkets föreskrifter och allmänna råd (SJÖFS 2008:4) om transport av last ska denna hänvisning istället avse dessa föreskrifter.

TSFS 2013:99

Denna författning träder i kraft den 1 januari 2014.

TSFS 2014:119

Denna författning träder i kraft den 16 december 2014.

TSFS 2016:52

Denna författning träder i kraft den 1 juli 2016.

TSFS 2016:92

Denna författning träder i kraft den 18 september 2016.

Bilaga 1. Bestämning av verifierad bruttovikt (VGM) enligt metod 1 och metod 2

Beskrivning av vägningsmetoderna

Metod 1

Metod 1 innebär att en packad container vägs som en enhet för att fastställa dess verifierade bruttovikt (VGM).

Bestämmelser om vågar finns i Swedacs föreskrifter (STAFS 2016:7) om automatiska vågar och Swedacs föreskrifter och allmänna råd (STAFS 2016:12) om icke-automatiska vågar.

Noggrannhetsklassen hos vågen ska vara lämplig för ändamålet

Bestämmelser om återkommande kontroll av vågar finns i Swedacs föreskrifter och allmänna råd (STAFS 2007:19) om icke-automatiska vågar och Swedacs föreskrifter (STAFS 2007:1) om automatiska vågar.

Under tiden fram till den 1 juli 2017 får istället vägningsutrustning användas som säkerställer en noggrannhet på ± 1 ton.

Metod 2

Metod 2 innebär att den verifierade bruttovikten (VGM) av en packad container bestäms genom summering av de ingående delvikterna.

Användande av denna metod förutsätter att processen är beskriven i ett kvalitetsledningssystem eller i en separat certifierad process för vägningen. Separat process för vägning ska vara certifierad av ett ackrediterat certifieringsorgan.

Kvalitetsledningssystemet kan vara uppbyggt enligt SS-EN ISO 9001 eller motsvarande samt revideras enligt SS-EN ISO 19011 eller motsvarande. Företrädesvis är kvalitetsledningssystemet certifierat av ett ackrediterat certifieringsorgan. Vid egen vägning enligt steg 1–3 nedan av ingående delvikter förutsätts det att industrin sedan tidigare är utrustad med vägningsutrustning som har en noggrannhet som lämpar sig för den vägning som avses.

Vikten ska fastställas för alla delvikter, inklusive vikten av lastpallar, förstängningsmaterial och andra lastsäkringsmaterial som ska ingå i lasten i containern. Containerns egenvikt adderas till summan av de individuella vikterna.

Tillämpning av metod 2

Följande steg vid tillämpning av metod 2 ska genomföras.

Steg 1 – lastens vikt

Den sammanlagda vikten av dellaster som ska transporteras ska bestämmas genom summering av vikten för varje enskild dellast. Viktsuppgifterna hämtas från egen vägning eller från tillförlitlig information från leverantören av dellasten. Vad gäller bulkvaror kan vikten ha blivit bestämd i produk-

tionsprocessen antingen genom vägning med fyllningsutrustning eller genom vägning av produkten, med en noggrannhet som lämpar sig för den vägning som avses.

Steg 2 – förpackningens vikt

Vikten av förpackningar summeras. Viktsuppgifterna hämtas från egen vägning, från tillverkaren av förpackningen, eller från en databas som stöds av ett kvalitetsledningssystem eller motsvarande. Under alla omständigheter ska giltigheten av denna information vara säkerställd.

Steg 3 – vikten av lastpallar, surningsutrustning och förstängningsmaterial

Vikten av lastpallar och lastsäkringsutrustning såsom spännband, fästpunkter och förstängningsmaterial summeras. Viktsuppgifterna hämtas från egen vägning, från tillverkaren eller från en databas som stöds av ett kvalitetsledningssystem eller motsvarande. Under alla omständigheter ska giltigheten av denna information vara säkerställd.

Steg 4 – vikten av tom container (taravikt)

Den uppgift på egenvikt som anges på containern ska användas.

Steg 5 – bruttovikt av packad container

Vikter erhållna genom steg 1 till 4 ska summeras.

FORMULÄR FÖR LASTINFORMATION Referensnr.

Transportköpare:	Varumottagare:
Transportföretag:	
Namn/typ av transport:	

Instruktioner o.dyl.:	
Avgångshamn/-plats:	Destinationshamn/-plats:
Allmän beskrivning av lasten (Typ av material/partikelstorlek):	
Bruttovikt utan krav på VGM [kg eller metriska ton]:	
Verifierad bruttovikt, VGM ¹⁾ för container [kg eller metriska ton]:	
<input type="checkbox"/> Container	Containernummer:
<input type="checkbox"/> Styckegods	
<input type="checkbox"/> Lastenheter	
<input type="checkbox"/> Bulklast	Specifikation av bulklast*
	Stuvningsfaktor
	Rasvinkel
	Trimningsmetoder
	Kemiska egenskaper† vid ev. risk
	*Om tillämpligt
	† T.ex. IMO-klass, UN nr eller transportbenämning i enlighet med Transportstyrelsens föreskrifter (TSFS 2010:166) om transport till sjöss av fast gods i bulk (IMSBC-koden)
Speciella lastegenskaper av betydelse:	
Ytterligare certifikat*	
<input type="checkbox"/>	Certifikat över fukttinhåll och fuktgräns för transport
<input type="checkbox"/>	Lutningscertifikat/Tätningcertifikat
<input type="checkbox"/>	Undantagscertifikat
<input type="checkbox"/>	Annat (specificera)
* vid behov	

¹⁾ Container för internationell sjötransport utan verifierad bruttovikt (VGM) får inte lastas ombord på fartyg.

FÖRSÄKRAN

Jag försäkrar härmed att lastpartiet är fullständigt och noggrant beskrivet och att noterade testresultat och andra specifikationer är korrekta, såvitt jag vet, och kan anses typiska för det gods som ska lastas.

Undertecknat

Namn/befattning: _____ Transportköparens ombuds signatur

.....
Företag/organisation: _____

.....
Ort och datum _____ Ort och datum

.....

FORM FOR CARGO INFORMATION Transport Document No.....

Shipper:	Consignee:
Carrier:	
Name/Means of transport:	
Instructions or other matters:	
Port/Place of departure:	Port/Place of destination:
General description of the cargo (type of material/particle size):	
Gross mass without VGM-requirement [kg or tonnes]:	
Verified gross mass, VGM ¹⁾ for container[kg or tonnes]:	
<input type="checkbox"/> Container	Container No:
<input type="checkbox"/> General cargo	
<input type="checkbox"/> Load units	
<input type="checkbox"/> Bulk cargo	Specification of bulk cargo*
	Stowage factor
	Angle of repose
	Trimming procedures
	Chemical properties if potential hazard†
	*If applicable
	† For example IMO class, UN No. or bulk cargo shipping name in accordance with the Swedish Transport Agency's Regulations (TSFS 2010:166) on maritime transport of solid bulk cargoes (IMSBC).
Special properties of importance of the cargo	
Additional certificate(s)*	
<input type="checkbox"/> Certificate of moisture content and transportable moisture limit	
<input type="checkbox"/> Weathering certificate	
<input type="checkbox"/> Exemption certificate	
<input type="checkbox"/> Other (specify)	
* If required	

¹⁾ Container for international transport by sea without verified gross mass (VGM) shall not be loaded onboard the ship.

DECLARATION

I hereby declare that the consignment is fully and accurately described and that the given test results and other specifications are correct to the best of my knowledge and belief and can be considered as representative for the cargo to be loaded.

Signature

Name/status: _____ Signature on behalf of the shipper

.....
Company/organization: _____

.....
Place and date: _____ Place and date: _____

.....
.....

(TSFS 2016:52)



E

4 ALBERT EMBANKMENT
LONDON SE1 7SR
Telephone: +44 (0)20 7735 7611 Fax: +44 (0)20 7587 3210

Ref. T1/1.02

MSC.1/Circ.1353
30 June 2010

REVISED GUIDELINES FOR THE PREPARATION OF THE CARGO SECURING MANUAL

1 In accordance with regulations VI/5 and VII/5 of the 1974 SOLAS Convention, as amended, cargo units and cargo transport units shall be loaded, stowed and secured throughout the voyage in accordance with the Cargo Securing Manual approved by the Administration, which shall be drawn up to a standard at least equivalent to the guidelines developed by the Organization.

2 The Maritime Safety Committee, at its eighty-seventh session (12 to 21 May 2010), considered the proposal by the Sub-Committee on Dangerous Goods, Solid Cargoes and Containers, at its fourteenth session (21 to 25 September 2009), and approved the Revised Guidelines for the preparation of the Cargo Securing Manual, as set out in the annex.

3 These Revised Guidelines are based on the provisions contained in the annex to MSC/Circ.745 but have been expanded to include the safe access for lashing of containers, taking into account the provisions of the Code of Safe Practice for Cargo Stowage and Securing (CSS Code), as amended. They are of a general nature and intended to provide guidance on the preparation of such Cargo Securing Manuals, which are required on all types of ships engaged in the carriage of cargoes other than solid and liquid bulk cargoes.

4 Member Governments are invited to bring these Guidelines to the attention of all parties concerned, with the aim of having Cargo Securing Manuals carried on board ships prepared appropriately and in a consistent manner, and to:

- .1 apply the revised guidelines in its entirety for containerships, the keels of which were laid or which are at a similar stage of construction on or after 1 January 2015; and
- .2 apply chapters 1 to 4 of the revised guidelines to existing containerships, the keels of which were laid or which were at a similar stage of construction before 1 January 2015.

5 This circular supersedes MSC/Circ.745.

ANNEX**REVISED GUIDELINES FOR THE PREPARATION OF
THE CARGO SECURING MANUAL****PREAMBLE**

1 In accordance with the International Convention for the Safety of Life at Sea, 1974 (SOLAS) chapters VI, VII and the Code of Safe Practice for Cargo Stowage and Securing (CSS Code), cargo units, including containers shall be stowed and secured throughout the voyage in accordance with a Cargo Securing Manual, approved by the Administration.

2 The Cargo Securing Manual is required on all types of ships engaged in the carriage of all cargoes other than solid and liquid bulk cargoes.

3 The purpose of these guidelines is to ensure that Cargo Securing Manuals cover all relevant aspects of cargo stowage and securing and to provide a uniform approach to the preparation of Cargo Securing Manuals, their layout and content. Administrations may continue accepting Cargo Securing Manuals drafted in accordance with Containers and cargoes (BC) – Cargo Securing Manual (MSC/Circ.385) provided that they satisfy the requirements of these guidelines.

4 If necessary, those manuals should be revised explicitly when the ship is intended to carry containers in a standardized system.

5 It is important that securing devices meet acceptable functional and strength criteria applicable to the ship and its cargo. It is also important that the officers on board are aware of the magnitude and direction of the forces involved and the correct application and limitations of the cargo securing devices. The crew and other persons employed for the securing of cargoes should be instructed in the correct application and use of the cargo securing devices on board the ship.

CHAPTER 1 – GENERAL**1.1 Definitions**

1.1.1 *Cargo securing devices* are all fixed and portable devices used to secure and support cargo units.

1.1.2 *Maximum securing load (MSL)* is a term used to define the allowable load capacity for a device used to secure cargo to a ship. *Safe working load (SWL)* may be substituted for MSL for securing purposes, provided this is equal to or exceeds the strength defined by MSL.

1.1.3 *Standardized cargo* means cargo for which the ship is provided with an approved securing system based upon cargo units of specific types.

1.1.4 *Semi-standardized cargo* means cargo for which the ship is provided with a securing system capable of accommodating a limited variety of cargo units, such as vehicles, trailers, etc.

1.1.5 *Non-standardized cargo* means cargo which requires individual stowage and securing arrangements.

1.2 Preparation of the manual

The Cargo Securing Manual should be developed, taking into account the recommendations given in these Guidelines, and should be written in the working language or languages of the ship. If the language or languages used is not English, French or Spanish, a translation into one of these languages should be included.

1.3 General information

This chapter should contain the following general statements:

- .1 "The guidance given herein should by no means rule out the principles of good seamanship, neither can it replace experience in stowage and securing practice."
- .2 "The information and requirements set forth in this Manual are consistent with the requirements of the vessel's trim and stability booklet, International Load Line Certificate (1966), the hull strength loading manual (if provided) and with the requirements of the International Maritime Dangerous Goods (IMDG) Code (if applicable)."
- .3 "This Cargo Securing Manual specifies arrangements and cargo securing devices provided on board the ship for the correct application to and the securing of cargo units, containers, vehicles and other entities, based on transverse, longitudinal and vertical forces which may arise during adverse weather and sea conditions."
- .4 "It is imperative to the safety of the ship and the protection of the cargo and personnel that the securing of the cargo is carried out properly and that only appropriate securing points or fittings should be used for cargo securing."
- .5 "The cargo securing devices mentioned in this manual should be applied so as to be suitable and adapted to the quantity, type of packaging, and physical properties of the cargo to be carried. When new or alternative types of cargo securing devices are introduced, the Cargo Securing Manual should be revised accordingly. Alternative cargo securing devices introduced should not have less strength than the devices being replaced."
- .6 "There should be a sufficient quantity of reserve cargo securing devices on board the ship."
- .7 "Information on the strength and instructions for the use and maintenance of each specific type of cargo securing device, where applicable, is provided in this manual. The cargo securing devices should be maintained in a satisfactory condition. Items worn or damaged to such an extent that their quality is impaired should be replaced."
- .8 The Cargo Safe Access Plan (CSAP) is intended to provide detailed information for persons engaged in work connected with cargo stowage and securing. Safe access should be provided and maintained in accordance with this plan.

CHAPTER 2 – SECURING DEVICES AND ARRANGEMENTS**2.1 Specification for fixed cargo securing devices**

This sub-chapter should indicate and where necessary illustrate the number, locations, type and MSL of the fixed devices used to secure cargo and should as a minimum contain the following information:

- 2.1.1 a list and/or plan of the fixed cargo securing devices, which should be supplemented with appropriate documentation for each type of device as far as practicable. The appropriate documentation should include information as applicable regarding:
- .1 name of manufacturer;
 - .2 type designation of item with simple sketch for ease of identification;
 - .3 material(s);
 - .4 identification marking;
 - .5 strength test result or ultimate tensile strength test result;
 - .6 result of non destructive testing; and
 - .7 Maximum Securing Load (MSL);
- 2.1.2 fixed securing devices on bulkheads, web frames, stanchions, etc. and their types (e.g., pad eyes, eyebolts, etc.), where provided, including their MSL;
- 2.1.3 fixed securing devices on decks and their types (e.g., elephant foot fittings, container fittings, apertures, etc.) where provided, including their MSL;
- 2.1.4 fixed securing devices on deckheads, where provided, listing their types and MSL; and
- 2.1.5 for existing ships with non-standardized fixed securing devices, the information on MSL and location of securing points is deemed sufficient.

2.2 Specification for portable cargo securing devices

This sub-chapter should describe the number of and the functional and design characteristics of the portable cargo securing devices carried on board the ship, and should be supplemented by suitable drawings or sketches if deemed necessary. It should contain the following information as applicable:

- 2.2.1 a list for the portable securing devices, which should be supplemented with appropriate documentation for each type of device, as far as practicable. The appropriate documentation should include information as applicable regarding:
- .1 name of manufacturer;
 - .2 type designation of item with simple sketch for ease of identification;
 - .3 material(s), including minimum safe operational temperature;
 - .4 identification marking;
 - .5 strength test result or ultimate tensile strength test result;
 - .6 result of non destructive testing; and
 - .7 Maximum Securing Load (MSL);
- 2.2.2 container stacking fittings, container deck securing fittings, fittings for interlocking of containers, bridge-fittings, etc., their MSL and use;
- 2.2.3 chains, wire lashings, rods, etc., their MSL and use;

MSC.1/Circ.1353
Annex, page 4

- 2.2.4 tensioners (e.g., turnbuckles, chain tensioners, etc.), their MSL and use;
- 2.2.5 securing gear for cars, if appropriate, and other vehicles, their MSL and use;
- 2.2.6 trestles and jacks, etc., for vehicles (trailers) where provided, including their MSL and use; and
- 2.2.7 anti-skid material (e.g., soft boards) for use with cargo units having low frictional characteristics.

2.3 Inspection and maintenance schemes

This sub-chapter should describe inspection and maintenance schemes of the cargo securing devices on board the ship.

2.3.1 Regular inspections and maintenance should be carried out under the responsibility of the master. Cargo securing devices inspections as a minimum should include:

- .1 routine visual examinations of components being utilized; and
- .2 periodic examinations/re-testing as required by the Administration. When required, the cargo securing devices concerned should be subjected to inspections by the Administration.

2.3.2 This sub-chapter should document actions to inspect and maintain the ship's cargo securing devices. Entries should be made in a record book, which should be kept with the Cargo Securing Manual. This record book should contain the following information:

- .1 procedures for accepting, maintaining and repairing or rejecting cargo securing devices; and
- .2 record of inspections.

2.3.3 This sub-chapter should contain information for the master regarding inspections and adjustment of securing arrangements during the voyage.

2.3.4 Computerized maintenance procedures may be referred to in this sub-chapter.

CHAPTER 3 – STOWAGE AND SECURING OF NON-STANDARDIZED AND SEMI-STANDARDIZED CARGO

3.1 Handling and safety instructions

This sub-chapter should contain:

- .1 instructions on the proper handling of the securing devices; and
- .2 safety instructions related to handling of securing devices and to securing and unsecuring of units by ship or shore personnel.

3.2 Evaluation of forces acting on cargo units

This sub-chapter should contain the following information:

- .1 tables or diagrams giving a broad outline of the accelerations which can be expected in various positions on board the ship in adverse sea conditions and with a range of applicable metacentric height (GM) values;
- .2 examples of the forces acting on typical cargo units when subjected to the accelerations referred to in paragraph 3.2.1 and angles of roll and metacentric height (GM) values above which the forces acting on the cargo units exceed the permissible limit for the specified securing arrangements as far as practicable;
- .3 examples of how to calculate number and strength of portable securing devices required to counteract the forces referred to in 3.2.2 as well as safety factors to be used for different types of portable cargo securing devices. Calculations may be carried out according to Annex 13 to the CSS Code or methods accepted by the Administration;
- .4 it is recommended that the designer of a Cargo Securing Manual converts the calculation method used into a form suiting the particular ship, its securing devices and the cargo carried. This form may consist of applicable diagrams, tables or calculated examples; and
- .5 other operational arrangements such as electronic data processing (EDP) or use of a loading computer may be accepted as alternatives to the requirements of the above paragraphs 3.2.1 to 3.2.4, providing that this system contains the same information.

3.3 Application of portable securing devices on various cargo units, vehicles and stowage blocks

3.3.1 This sub-chapter should draw the master's attention to the correct application of portable securing devices, taking into account the following factors:

- .1 duration of the voyage;
- .2 geographical area of the voyage with particular regard to the minimum safe operational temperature of the portable securing devices;
- .3 sea conditions which may be expected;
- .4 dimensions, design and characteristics of the ship;
- .5 expected static and dynamic forces during the voyage;
- .6 type and packaging of cargo units including vehicles;
- .7 intended stowage pattern of the cargo units including vehicles; and
- .8 mass and dimensions of the cargo units and vehicles.

MSC.1/Circ.1353
Annex, page 6

3.3.2 This sub-chapter should describe the application of portable cargo securing devices as to number of lashings and allowable lashing angles. Where necessary, the text should be supplemented by suitable drawings or sketches to facilitate the correct understanding and proper application of the securing devices to various types of cargo and cargo units. It should be pointed out that for certain cargo units and other entities with low friction resistance, it is advisable to place soft boards or other anti-skid material under the cargo to increase friction between the deck and the cargo.

3.3.3 This sub-chapter should contain guidance as to the recommended location and method of stowing and securing of containers, trailers and other cargo carrying vehicles, palletized cargoes, unit loads and single cargo items (e.g., woodpulp, paper rolls, etc.), heavy weight cargoes, cars and other vehicles.

3.4 Supplementary requirements for ro-ro ships

3.4.1 The manual should contain sketches showing the layout of the fixed securing devices with identification of strength (MSL) as well as longitudinal and transverse distances between securing points. In preparing this sub-chapter further guidance should be utilized from IMO Assembly resolutions A.533(13) and A.581(14), as appropriate.

3.4.2 In designing securing arrangements for cargo units, including vehicles and containers, on ro-ro passenger ships and specifying minimum strength requirements for securing devices used, forces due to the motion of the ship, angle of heel after damage or flooding and other considerations relevant to the effectiveness of the cargo securing arrangement should be taken into account.

3.5 Bulk carriers

If bulk carriers carry cargo units falling within the scope of chapter VI/5 or chapter VII/5 of the SOLAS Convention, this cargo shall be stowed and secured in accordance with a Cargo Securing Manual, approved by the Administration.

CHAPTER 4 – STOWAGE AND SECURING OF CONTAINERS AND OTHER STANDARDIZED CARGO

4.1 Handling and safety instructions

This sub-chapter should contain:

- .1 instructions on the proper handling of the securing devices; and
- .2 safety instructions related to handling of securing devices and to securing and unsecuring of containers or other standardized cargo by ship or shore personnel.

4.2 Stowage and securing instructions

This sub-chapter is applicable to any stowage and securing system (i.e. stowage within or without cellguides) for containers and other standardized cargo. On existing ships the relevant documents regarding safe stowage and securing may be integrated into the material used for the preparation of this chapter.

4.2.1 Stowage and securing plan

This sub-chapter should consist of a comprehensive and understandable plan or set of plans providing the necessary overview on:

- .1 longitudinal and athwartship views of under deck and on deck stowage locations of containers as appropriate;
- .2 alternative stowage patterns for containers of different dimensions;
- .3 maximum stack masses;
- .4 permissible vertical sequences of masses in stacks;
- .5 maximum stack heights with respect to approved sight lines; and
- .6 application of securing devices using suitable symbols with due regard to stowage position, stack mass, sequence of masses in stack and stack height. The symbols used should be consistent throughout the Cargo Securing Manual.

4.2.2 Stowage and securing principle on deck and under deck

This sub-chapter should support the interpretation of the stowage and securing plan with regard to container stowage, highlighting:

- .1 the use of the specified devices; and
- .2 any guiding or limiting parameters as dimension of containers, maximum stack masses, sequence of masses in stacks, stacks affected by wind load, height of stacks.

It should contain specific warnings of possible consequences from misuse of securing devices or misinterpretation of instructions given.

4.3 Other allowable stowage patterns

4.3.1 This sub-chapter should provide the necessary information for the master to deal with cargo stowage situations deviating from the general instructions addressed under sub-chapter 4.2, including appropriate warnings of possible consequences from misuse of securing devices or misinterpretation of instructions given.

4.3.2 Information should be provided with regard to, *inter alia*:

- .1 alternative vertical sequences of masses in stacks;
- .2 stacks affected by wind load in the absence of outer stacks;
- .3 alternative stowage of containers with various dimensions; and
- .4 permissible reduction of securing effort with regard to lower stacks masses, lesser stack heights or other reasons.

4.4 Forces acting on cargo units

4.4.1 This sub-chapter should present the distribution of accelerations on which the stowage and securing system is based, and specify the underlying condition of stability. Information on forces induced by wind and sea on deck cargo should be provided.

4.4.2 It should further contain information on the nominal increase of forces or accelerations with an increase of initial stability. Recommendations should be given for reducing the risk of cargo losses from deck stowage by restrictions to stack masses or stack heights, where high initial stability cannot be avoided.

CHAPTER 5 – CARGO SAFE ACCESS PLAN (CSAP)

5.1 Ships which are specifically designed and fitted for the purpose of carrying containers should be provided with a Cargo Safe Access Plan (CSAP) in order to demonstrate that personnel will have safe access for container securing operations. This plan should detail arrangements necessary for the conducting of cargo stowage and securing in a safe manner. It should include the following for all areas to be worked by personnel:

- .1 hand rails;
- .2 platforms;
- .3 walkways;
- .4 ladders;
- .5 access covers;
- .6 location of equipment storage facilities;
- .7 lighting fixtures;
- .8 container alignment on hatch covers/pedestals;
- .9 fittings for specialized containers, such as reefer plugs/receptacles;
- .10 first aid stations and emergency access/egress;
- .11 gangways; and
- .12 any other arrangements necessary for the provision of safe access.

5.2 Guidelines for specific requirements are contained in annex 14 to the CSS Code.

(TSFS 2013:99)

Resolution A.714(17)
Adopted on 6 November 1991
(Agenda item 10)

CODE OF SAFE PRACTICE FOR CARGO STOWAGE AND SECURING

THE ASSEMBLY,

RECALLING Article 15(j) of the Convention on the International Maritime Organization concerning the functions of the Assembly in relation to regulations and guidelines concerning maritime safety,

RECALLING ALSO resolution A.489(XII) on safe stowage and securing of cargo units and other entities in ships other than cellular containerships and MSC/Circ.385 of January 1985 containing the provisions to be included in a cargo securing manual to be carried on board ships,

RECALLING FURTHER resolution A.533(13) on elements to be taken into account when considering the safe stowage and securing of cargo units and vehicles in ships,

CONSIDERING the revised IMO/ILO Guidelines for Packing Cargo in Freight Containers or Vehicles,

CONSIDERING ALSO resolution A.581(14) on guidelines for securing arrangements for the transport of road vehicles on ro-ro ships,

BEARING IN MIND that a number of serious accidents have occurred as a result of inadequate securing arrangements on board and deficient stowage and securing of cargoes in vehicles and containers, and that only proper stowage and securing of cargo on adequately designed and properly equipped ships can prevent the occurrence of such accidents in the future,

RECOGNIZING the need to improve the stowage and securing of cargoes shown by experience to create specific hazards to the safety of ships, and the stowage and securing of road vehicles transported on board ro-ro ships,

RECOGNIZING FURTHER that such improvement could be achieved by the establishment of a composite code of safe practice for cargo stowage and securing on board ships, including packing or loading cargo in road vehicles and freight containers,

BELIEVING that the application of such a code of safe practice would enhance maritime safety,

HAVING CONSIDERED the recommendations made by the Maritime Safety Committee at its fifty-eighth session,

1. ADOPTS the Code of Safe Practice for Cargo Stowage and Securing set out in the annex to the present resolution;
2. URGES Governments to implement this Code at the earliest possible opportunity;
3. REQUESTS the Maritime Safety Committee to keep this Code under review and to amend it, as necessary;
4. REVOKES resolution A.288(VIII).

Annex

**CODE OF SAFE PRACTICE
FOR CARGO STOWAGE AND SECURING**

Table of contents

Foreword

General principles

Chapter 1 – General

Chapter 2 – Principles of safe stowage and securing of cargoes

Chapter 3 – Standardized stowage and securing systems

Chapter 4 – Semi-standardized stowage and securing

Chapter 5 – Non-standardized stowage and securing

Chapter 6 – Actions which may be taken in heavy weather

Chapter 7 – Actions which may be taken once cargo has shifted

Annex 1 – Safe stowage and securing of containers on deck of ships which are not specially designed and fitted for the purpose of carrying containers

Annex 2 – Safe stowage and securing of portable tanks

Annex 3 – Safe stowage and securing of portable receptacles

Annex 4 – Safe stowage and securing of wheel-based (rolling) cargoes

Annex 5 – Safe stowage and securing of heavy cargo items such as locomotives, transformers, etc.

Annex 6 – Safe stowage and securing of coiled sheet steel

Annex 7 – Safe stowage and securing of heavy metal products

Annex 8 – Safe stowage and securing of anchor chains

Annex 9 – Safe stowage and securing of metal scrap in bulk

Annex 10 – Safe stowage and securing of flexible intermediate bulk containers

Annex 11 – General guidelines for the under-deck stowage of logs

Annex 12 – Safe stowage and securing of unit loads

FOREWORD

The proper stowage and securing of cargoes is of the utmost importance for the safety of life at sea. Improper stowage and securing of cargoes has resulted in numerous serious ship casualties and caused injury and loss of life, not only at sea but also during loading and discharge.

In order to deal with the problems and hazards arising from improper stowage and securing of certain cargoes on ships, the International Maritime Organization has issued guidelines in the form of either Assembly resolutions or circulars adopted by the Maritime Safety Committee; these are listed hereunder:*

- Safe stowage and securing of cargo units and other entities in ships other than cellular containerships, resolution A.489(XII);
- Provisions to be included in the Cargo Securing Manual to be carried on board ships, MSC/Circ.385;
- Elements to be taken into account when considering the safe stowage and securing of cargo units and vehicles in ships, resolution A.533(13);
- Guidelines for securing arrangements for the transport of road vehicles on ro-ro ships, resolution A.581(14);
- IMO/ILO Guidelines for Packing Cargo in Freight Containers or Vehicles;
- Hazards associated with the entry into enclosed spaces, MSC/Circ.487.

The accelerations acting on a ship in a seaway result from a combination of longitudinal, vertical and predominantly transverse motions. The forces created by these accelerations give rise to the majority of securing problems.

The hazards arising from these forces should be dealt with by taking measures both to ensure proper stowage and securing of cargoes on board and to reduce the amplitude and frequency of ship motions.

The purpose of this Code is to provide an international standard to promote the safe stowage and securing of cargoes by:

- drawing the attention of shipowners and ship operators to the need to ensure that the ship is suitable for its intended purpose;
- providing advice to ensure that the ship is equipped with proper cargo securing means;
- providing general advice concerning the proper stowage and securing of cargoes to minimize the risks to the ship and personnel;
- providing specific advice on those cargoes which are known to create difficulties and hazards with regard to their stowage and securing;
- advising on actions which may be taken in heavy sea conditions; and
- advising on actions which may be taken to remedy the effects of cargo shifting.

In providing such advice, it should be borne in mind that the master is responsible for the safe conduct of the voyage and the safety of the ship, its crew and its cargo.

* The relevant resolutions, circulars and guidelines will be included as an appendix in the consolidated publication of the Assembly resolution and the Code.

GENERAL PRINCIPLES

All cargoes should be stowed and secured in such a way that the ship and persons on board are not put at risk.

The safe stowage and securing of cargoes depend on proper planning, execution and supervision.

Personnel commissioned to tasks of cargo stowage and securing should be properly qualified and experienced.

Personnel planning and supervising the stowage and securing of cargo should have a sound practical knowledge of the application and content of the Cargo Securing Manual, if provided.

In all cases, improper stowage and securing of cargo will be potentially hazardous to the securing of other cargoes and to the ship itself.

Decisions taken for measures of stowage and securing cargo should be based on the most severe weather conditions which may be expected by experience for the intended voyage.

Ship-handling decisions taken by the master, especially in bad weather conditions, should take into account the type and stowage position of the cargo and the securing arrangements.

CHAPTER 1 - GENERAL

1.1 Application

This Code applies to cargoes carried on board ships (other than solid and liquid bulk cargoes and timber stowed on deck) and, in particular, to those cargoes whose stowage and securing have proved in practice to create difficulties.

1.2 Definitions of the terms used

For the purposes of this Code:

Cargo unit means a vehicle, container, flat, pallet, portable tank, packaged unit, or any other entity, etc., and loading equipment, or any part thereof, which belongs to the ship but is not fixed to the ship as defined in Assembly resolution A.489(XII).

Intermediate bulk container (IBC) means a rigid, semi-rigid or flexible portable bulk container packaging of a capacity of not more than 3 m³ (3,000 l), designed for mechanical handling and tested for its satisfactory resistance to handling and transport stresses.

Portable tank means a tank which is not permanently secured on board a ship, and has a capacity of more than 450 l and a shell fitted with external stabilizing members and items of service equipment and structural equipment necessary for the transport of gases, liquids or solids.

Road tank-vehicle means a vehicle with wheels and fitted with a tank or tanks intended for the transport of gases, liquids or solids by both road and sea modes of transport, the tank or tanks of which are rigidly and permanently attached to the vehicle during all normal operations of loading, transport and discharge and are neither filled nor emptied on board.

Road vehicle means a commercial vehicle, semi-trailer, road train, articulated road train or a combination of vehicles, as defined in Assembly resolution A.581(14).

Roll-trailer means a low vehicle for the carriage of cargo with one or more wheel axles on the rear and a support on the front end, which is towed or pushed in the port to and from its stowage on board the ship by a special tow-vehicle.

Ro-ro ship means a ship which has one or more decks either closed or open, not normally subdivided in any way and generally running the entire length of the ship, carrying goods which are loaded and unloaded normally in a horizontal manner.

Unit load means that a number of packages are either:

- .1 placed or stacked, and secured by strapping, shrink-wrapping or other suitable means, on to a load board such as a pallet; or
- .2 placed in a protective outer packaging such as a pallet box; or
- .3 permanently secured together in a sling.

1.3 Forces

1.3.1 Forces, which have to be absorbed by suitable arrangements for stowage and securing to prevent cargo shifting, are generally composed of components acting relative to the axes of the ship:

- longitudinal;
- transversal; and
- vertical.

Remark: For the purpose of stowage and securing cargo, longitudinal and transverse forces are considered predominant.

1.3.2 Transverse forces alone, or the resultant of transverse, longitudinal and vertical forces, normally increase with the height of the stow and the longitudinal distance of the stow from the ship's centre of motion in a seaway. The most severe forces can be expected in the furthest forward, the furthest aft and the highest stowage position on each side of the ship.

1.3.3 The transverse forces exerted increase directly with the metacentric height of the ship. An undue metacentric height may be caused by:

- improper design of the ship;
- unsuitable cargo distribution; and
- unsuitable bunker and ballast distribution.

1.3.4 Cargo should be so distributed that the ship has a metacentric height in excess of the required minimum and, whenever practicable, within an acceptable upper limit to minimize the forces acting on the cargo.

1.3.5 In addition to the forces referred to above, cargo carried on deck may be subjected to forces arising from the effects of wind and green seas.

1.3.6 Improper shiphandling (course or speed) may create adverse forces acting on the ship and the cargo.

1.3.7 The magnitude of the forces may be estimated by using the appropriate calculation methods as contained in the Cargo Securing Manual, if provided.

1.3.8 Although the operation of anti-roll devices may improve the behaviour of the ship in a seaway, the effect of such devices should not be taken into account when planning the stowage and securing of cargoes.

1.4 Behaviour of cargoes

1.4.1 Some cargoes have a tendency to deform or to compact themselves during the voyage, which will result in a slackening of their securing gear.

1.4.2 Cargoes with low friction coefficients, when stowed without proper friction-increasing devices such as dunnage, soft boards, rubber mats, etc., are difficult to secure unless tightly stowed across the ship.

1.5 Criteria for estimating the risk of cargo shifting

1.5.1 When estimating the risk of cargo shifting, the following should be considered:

- dimensional and physical properties of the cargo;
- location of the cargo and its stowage on board;
- suitability of the ship for the particular cargo;
- suitability of the securing arrangements for the particular cargo;
- expected seasonal weather and sea conditions;
- expected ship behaviour during the intended voyage;
- stability of the ship;
- geographical area of the voyage; and
- duration of the voyage.

1.5.2 These criteria should be taken into account when selecting suitable stowage and securing methods and whenever reviewing the forces to be absorbed by the securing equipment.

1.5.3 Bearing in mind the above criteria, the master should accept the cargo on board his ship only if he is satisfied that it can be safely transported.

1.6 Cargo Securing Manual

1.6.1 Ships carrying cargo units and other entities covered in this Code and as outlined in resolution A.489(XII) (appendix) should carry a Cargo Securing Manual as detailed in MSC/Circ.385.

1.6.2 The cargo securing arrangements detailed in the ship's Cargo Securing Manual, if provided, should be based on the forces expected to affect the cargo carried by the ship, calculated in accordance with a method accepted by the Administration or approved by a classification society acceptable to the Administration.

1.7 Equipment

The ship's cargo securing equipment should be:

- available in sufficient quantity;
- suitable for its intended purpose, taking into account the recommendations of the Cargo Securing Manual, if provided;
- of adequate strength;
- easy to use; and
- well maintained.

1.8 Special cargo transport units

The shipowner and the ship operator should, where necessary, make use of relevant expertise when considering the shipment of a cargo with unusual characteristics which may require special attention to be given to its location on board vis-à-vis the structural strength of the ship, its stowage and securing, and the weather conditions which may be expected during the intended voyage.

1.9 Cargo information

1.9.1 Before accepting a cargo for shipment, the shipowner or ship operator should obtain all necessary information about the cargo and ensure that:

- the different commodities to be carried are compatible with each other or suitably separated;
- the cargo is suitable for the ship;
- the ship is suitable for the cargo; and
- the cargo can be safely stowed and secured on board the ship and transported under all expected conditions during the intended voyage.

1.9.2 The master should be provided with adequate information regarding the cargo to be carried so that its stowage may be properly planned for handling and transport.

CHAPTER 2 – PRINCIPLES OF SAFE STOWAGE AND SECURING OF CARGOES

2.1 Suitability of cargo for transport

Cargo carried in containers, road vehicles, shipborne barges, railway wagons and other cargo transport units should be packed and secured within these units so as to prevent, throughout the voyage, damage or hazard to the ship, to the persons on board and to the marine environment.

2.2 Cargo distribution

2.2.1 It is of utmost importance that the master takes great care in planning and supervising the stowage and securing of cargoes in order to prevent cargo sliding, tipping, racking, collapsing, etc.

2.2.2 The cargo should be distributed so as to ensure that the stability of the ship throughout the entire voyage remains within acceptable limits so that the hazards of excessive accelerations are reduced as far as practicable.

2.2.3 Cargo distribution should be such that the structural strength of the ship is not adversely affected.

2.3 Cargo securing arrangements

2.3.1 Particular care should be taken to distribute forces as evenly as practicable between the cargo securing devices. If this is not feasible, the arrangements should be upgraded accordingly.

2.3.2 If, due to the complex structure of a securing arrangement or other circumstances, the person in charge is unable to assess the suitability of the arrangement from experience and knowledge of good seamanship, the arrangement should be verified by using an acceptable calculation method.

2.4 Residual strength after wear and tear

Cargo securing arrangements and equipment should have sufficient residual strength to allow for normal wear and tear during their lifetime.

2.5 Friction forces

Where friction between the cargo and the ship's deck or structure or between cargo transport units is insufficient to avoid the risk of sliding, suitable material such as soft boards or dunnage should be used to increase friction.

2.6 Shipboard supervision

2.6.1 The principal means of preventing the improper stowage and securing of cargoes is through proper supervision of the loading operation and inspections of the stow.

2.6.2 As far as practicable, cargo spaces should be regularly inspected throughout the voyage to ensure that the cargo, vehicles and cargo transport units remain safely secured.

2.7 Entering enclosed spaces

The atmosphere in any enclosed space may be incapable of supporting human life through lack of oxygen or it may contain flammable or toxic gases. The master should ensure that it is safe to enter any enclosed space.

2.8 General elements to be considered by the master

Having evaluated the risk of cargo-shifting, taking into account the criteria set out in 1.5, the master should ensure, prior to loading of any cargo, cargo transport unit or vehicle that:

- .1 the deck area for their stowage is, as far as practicable, clean, dry and free from oil and grease;
- .2 the cargo, cargo transport unit or vehicle, appears to be in suitable condition for transport, and can be effectively secured;
- .3 all necessary cargo securing equipment is on board and in good working condition; and
- .4 cargo in or on cargo transport units and vehicles is, to the extent practicable, properly stowed and secured on to the unit or vehicle.

2.9 Cargo stowage and securing declaration

2.9.1 Where there is reason to suspect that a container or vehicle into which dangerous goods have been packed or loaded is not in compliance with the provisions of section 12 or 17, as appropriate, of the General Introduction to the IMDG Code, or where a container packing certificate/vehicle packing declaration is not available, the unit should not be accepted for shipment.

2.9.2 Where practicable and feasible, road vehicles should be provided with a cargo stowage and securing declaration, stating that the cargo on the road vehicle has been properly stowed and secured for the intended sea voyage, taking into account the IMO/ILO guidelines for packing cargo in freight containers or vehicles. An example of such a declaration is given hereunder. The vehicle packing declaration, recommended by the IMDG Code (see 2.9.1), may be acceptable for this purpose.

Example

CARGO STOWAGE AND SECURING DECLARATION	
Vehicle no.
Place of loading
Date of loading
Commodity(ies)
I hereby declare that the cargo on the above-mentioned vehicle has been properly stowed and secured for transport by sea, by taking into account the IMO/ILO Guidelines for Packing Cargo in Freight Containers or Vehicles.	
Name of signatory
Status
Place	Date
Signature on behalf of the packer	
Remarks:	
.....	
.....	
.....	
.....	
.....	

CHAPTER 3 – STANDARDIZED STOWAGE AND SECURING SYSTEMS

3.1 Recommendations

Ships intended for the carriage of cargoes in a standardized stowage and securing system (e.g. containers, railway wagons, shipborne barges, etc.) should be:

- .1 so designed and equipped that the standardized cargoes concerned can be safely stowed and secured on board under all conditions expected during the intended voyage;
- .2 of a design and so equipped as to be accepted by the Administration or approved by a classification society acceptable to the Administration; and
- .3 provided with adequate information, for use by the master, on the arrangements provided for the safe stowage and securing of the specific cargoes for which the ship is designed or adapted.

CHAPTER 4 – SEMI-STANDARDIZED STOWAGE AND SECURING

4.1 Securing arrangements

4.1.1 Ships intended for the carriage of certain specific cargoes such as road vehicles, systemized cargo carrying roll-trailers and automobiles on ro-ro ships, etc., should be provided with securing points spaced sufficiently close to each other for the intended operation of the ship and in accordance with section 4 of the guidelines for securing arrangements for the transport of road vehicles on ro-ro ships (resolution A.581(14)).

4.1.2 Road vehicles intended for transport by sea should be provided with arrangements for their safe stowage and securing, as detailed in section 5 of the annex to resolution A.581(14).

4.1.3 Roll-trailers carrying systemized cargo should be provided with arrangements for the safe stowage and securing of the vehicle and its cargo. Special consideration should be given to the height of the stow, the compactness of the stow and the effects of a high centre of gravity of the cargo.

4.2 Stowage and securing of vehicles

4.2.1 Vehicles, including roll-trailers not provided with adequate securing arrangements, should be stowed and secured in accordance with chapter 5 of this Code.

4.2.2 Ro-ro ships which do not comply with the requirements of section 4 of the annex to resolution A.581(14) or are not provided with equivalent stowage and securing means providing for an equivalent degree of safety during transport by sea should be dealt with in accordance with chapter 5 of this Code.

4.2.3 Vehicles should be stowed and secured in accordance with sections 6 and 7 of the annex to resolution A.581(14). Special consideration should be given to the stowage and securing of roll-trailers carrying systemized cargo, road tank-vehicles and portable tanks on wheels, taking into account the effects of a tank's high centre of gravity and free surface.

4.3 Acceptance of road vehicles for transport by sea on ro-ro ships

4.3.1 The master should not accept a road vehicle for transport on board his ship unless satisfied that the road vehicle is apparently suitable for the intended voyage and is provided with at least the securing points specified in section 5 of the annex to resolution A.581(14).

4.3.2 In exceptional circumstances, where there is some doubt that the recommendations of 4.3.1 can or need to be fulfilled, the master may accept the vehicle for shipment, after taking into account the condition of the vehicle and the expected nature of the intended voyage.

CHAPTER 5 – NON-STANDARDIZED STOWAGE AND SECURING

5.1 Recommendations

5.1.1 This chapter and the annexes provide advice of a general nature for the stowage and securing of cargoes not covered by chapters 3 and 4 of this Code and particularly specific advice for the stowage and securing of cargoes which have proved to be difficult to stow and secure on board ships.

5.1.2 The list of cargoes given in 5.3 should not be regarded as exhaustive, as there may be other cargoes which could create hazards if not properly stowed and secured.

5.2 Equivalent stowage and securing

The guidance given in the annexes provides for certain safeguards against the problems inherent in the cargoes covered. Alternative methods of stowage and securing may afford the same degree of safety. It is imperative that any alternative method chosen should provide a level of securing safety at least equivalent to that described in the resolutions, circulars and guidelines listed in the foreword to this Code.

5.3 Cargoes which have proved to be a potential source of danger

Such cargoes include:

- .1 containers when carried on deck of ships which are not specially designed and fitted for the purpose of carrying containers (annex 1);
- .2 portable tanks (tank-containers) (annex 2);
- .3 portable receptacles (annex 3);
- .4 special wheel-based (rolling) cargoes (annex 4);
- .5 heavy cargo items such as locomotives, transformers, etc. (annex 5);
- .6 coiled sheet steel (annex 6);
- .7 heavy metal products (annex 7);
- .8 anchor chains (annex 8);
- .9 metal scrap in bulk (annex 9);
- .10 flexible intermediate bulk containers (FIBCs) (annex 10);
- .11 logs in under-deck stow (annex 11); and
- .12 unit loads (annex 12).

CHAPTER 6 – ACTIONS WHICH MAY BE TAKEN IN HEAVY WEATHER

6.1 General

The purpose of this chapter is not to usurp the responsibilities of the master, but rather to offer some advice on how stresses induced by excessive accelerations caused by bad weather conditions could be avoided.

6.2 Excessive accelerations

Measures to avoid excessive accelerations are:

- .1 alteration of course or speed or a combination of both;
- .2 heaving to;

- .3 early avoidance of areas of adverse weather and sea conditions; and
- .4 timely ballasting or deballasting to improve the behaviour of the ship, taking into account the actual stability conditions (see also 7.2).

6.3 Voyage planning

One way of reducing excessive accelerations is for the master, as far as possible and practicable, to plan the voyage of the ship carefully so as to avoid areas with severe weather and sea conditions. The master should always consult the latest available weather information.

CHAPTER 7 – ACTIONS WHICH MAY BE TAKEN ONCE CARGO HAS SHIFTED

7.1 The following actions may be considered:

- .1 alterations of course to reduce accelerations;
- .2 reductions of speed to reduce accelerations and vibration;
- .3 monitoring the integrity of the ship;
- .4 restowing or resecuring the cargo and, where possible, increasing the friction; and
- .5 diversion of route in order to seek shelter or improved weather and sea conditions.

7.2 Tank ballasting or deballasting operations should be considered only if the ship has adequate stability.

Annex 1

Safe stowage and securing of containers on deck of ships which are not specially designed and fitted for the purpose of carrying containers

1 STOWAGE

1.1 Containers carried on deck or on hatches of such ships should preferably be stowed in the fore-and-aft direction.

1.2 Containers should not extend over the ship's sides. Adequate supports should be provided when containers overhang hatches or deck structures.

1.3 Containers should be stowed and secured so as to permit safe access for personnel in the necessary operation of the ship.

1.4 Containers should at no time overstress the deck or hatches on which they are stowed.

1.5 Bottom-tier containers, when not resting on stacking devices, should be stowed on timber of sufficient thickness, arranged in such a way as to transfer the stack load evenly on to the structure of the stowage area.

1.6 When stacking containers, use should be made of locking devices, cones, or similar stacking aids, as appropriate, between them.

1.7 When stowing containers on deck or hatches, the position and strength of the securing points should be taken into consideration.

2 SECURING

2.1 All containers should be effectively secured in such a way as to protect them from sliding and tipping. Hatch covers carrying containers should be adequately secured to the ship.

2.2 Containers should be secured using one of the three methods recommended in figure 1 or methods equivalent thereto.

2.3 Lashings should preferably consist of wire ropes or chains or material with equivalent strength and elongation characteristics.

2.4 Timber shoring should not exceed 2 m in length.

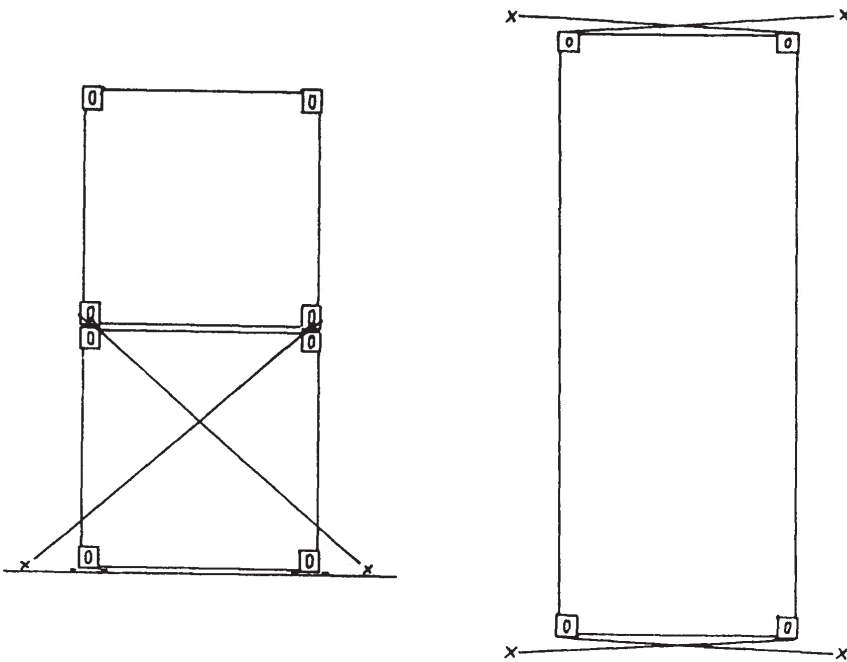

Method A – *Medium-weight containers: weight of top container not more than 70% of that of bottom container*

Figure 1 – Recommended methods of non-standardized securing of containers

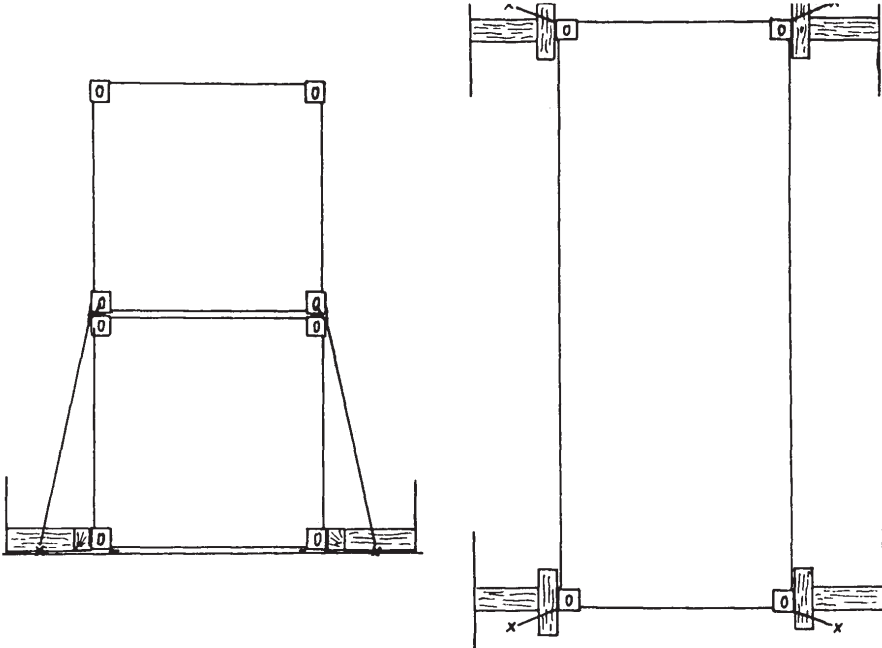

Method B – Medium-weight containers: weight of top container may be more than 70% of that of bottom container

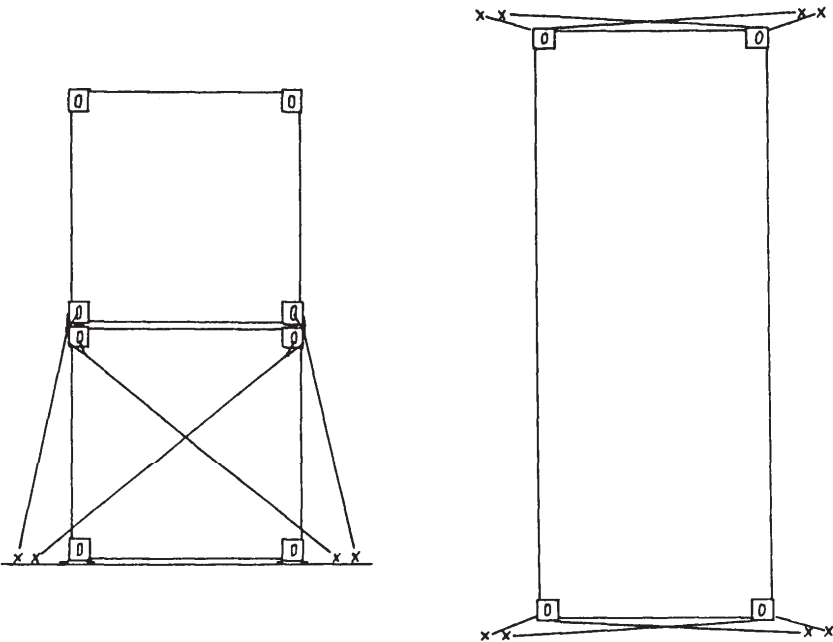

Method C – Heavyweight containers: weight of top container may be more than 70% of that of bottom container

Figure 1 – Recommended methods of non-standardized securing of containers (cont.)

2.5 Wire clips should be adequately greased, and tightened so that the dead end of the wire is visibly compressed (figure 2).

2.6 Lashings should be kept, when possible, under equal tension.

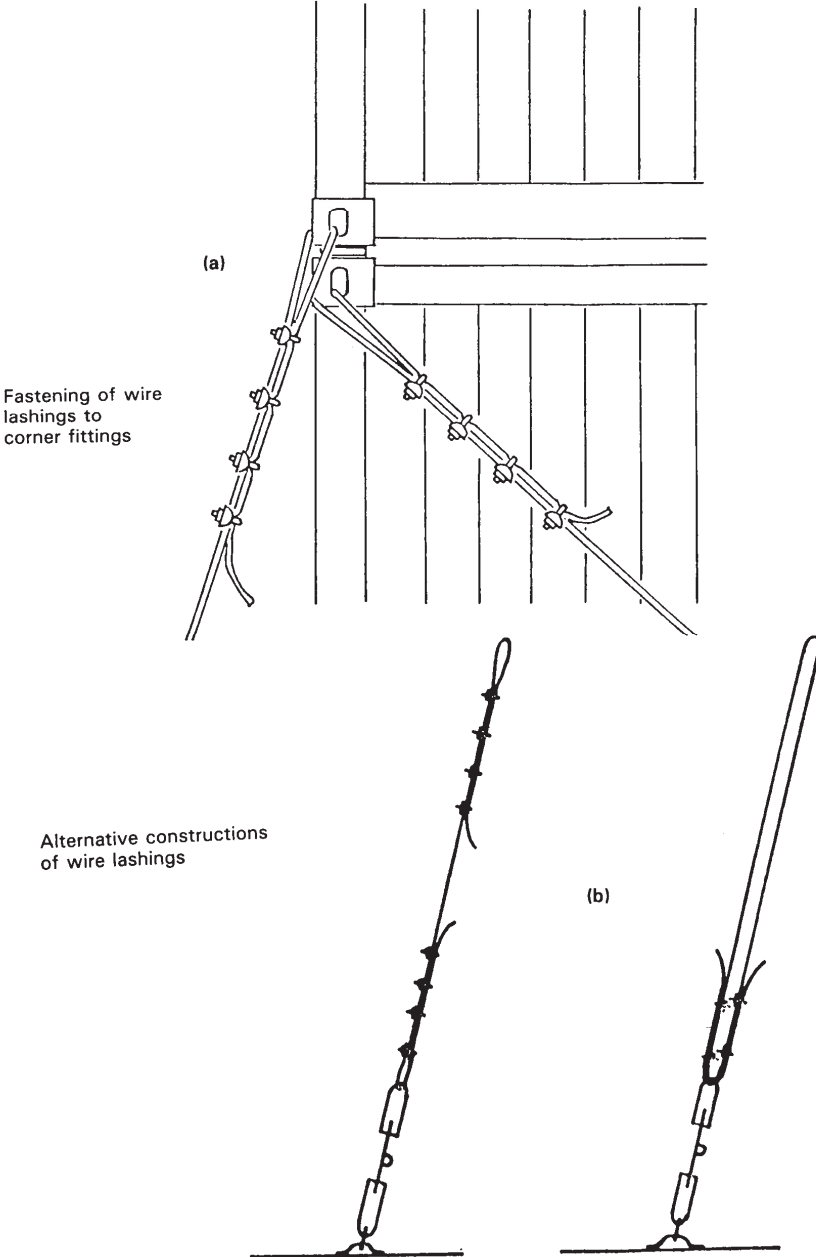

Figure 2

Annex 2

Safe stowage and securing of portable tanks

1 INTRODUCTION

1.1 The provisions of this annex apply to a portable tank, which in the context of this annex, means a tank which is not permanently secured on board the vessel and has a capacity of more than 450 l and a shell fitted with external stabilizing members and items of service equipment and structural equipment necessary for the transport of liquids, solids or gases.

1.2 These provisions do not apply to tanks intended for the transport of liquids, solids or gases having a capacity of 450 l or less.

Note: The capacity for portable tanks for gases is 1,000 l or more.

2 GENERAL PROVISIONS FOR PORTABLE TANKS

2.1 Portable tanks should be capable of being loaded and discharged without the need of removal of their structural equipment and be capable of being lifted on to and off the ship when loaded.

2.2 The applicable requirements of the International Convention for Safe Containers (CSC), 1972, as amended, should be fulfilled by any tank-container which meets the definition of a container within the terms of that Convention. Additionally, the provisions of section 13 of the General Introduction to the IMDG Code should be met when the tank will be used for the transport of dangerous goods.

2.3 Portable tanks should not be offered for shipment in an ullage condition liable to produce an unacceptable hydraulic force due to surge within the tank.

2.4 Portable tanks for the transport of dangerous goods should be certified in accordance with the provisions of the IMDG Code by the competent approval authority or a body authorized by that authority.

3 PORTABLE TANK ARRANGEMENT

3.1 The external stabilizing members of a portable tank may consist of skids or cradles and, in addition, the tank may be secured to a platform-based container. Alternatively, a tank may be fixed within a framework of ISO or non-ISO frame dimensions.

3.2 Portable tank arrangements should include fittings for lifting and securing on board.

Note: All types of the aforementioned portable tanks may be carried on multipurpose ships but need special attention for lashing and securing on board.

4 CARGO INFORMATION

4.1 The master should be provided with at least the following information:

- .1 dimensions of the portable tank and commodity if non-dangerous and, if dangerous, the information required in accordance with the IMDG Code;
- .2 the gross mass of the portable tank; and
- .3 whether the portable tank is permanently secured on to a platform-based container or in a frame and whether securing points are provided.

5 STOWAGE

- 5.1 The typical distribution of accelerations of the ship should be borne in mind in deciding whether the portable tank will be stowed on or under deck.
- 5.2 Tanks should be stowed in the fore-and-aft direction on or under deck.
- 5.3 Tanks should be stowed so that they do not extend over the ship's side.
- 5.4 Tanks should be stowed so as to permit safe access for personnel in the necessary operation of the ship.
- 5.5 At no time should the tanks overstress the deck or hatches; the hatchcovers should be so secured to the ship that tipping of the entire hatchcover is prevented.

6 SECURING AGAINST SLIDING AND TIPPING

6.1 Non-standardized portable tanks

6.1.1 The securing devices on non-standardized portable tanks and on the ship should be arranged in such a way as to withstand the transverse and longitudinal forces, which may give rise to sliding and tipping. The lashing angles against sliding should not be higher than 25° and against tipping not lower than 45° to 60° (figure 1).

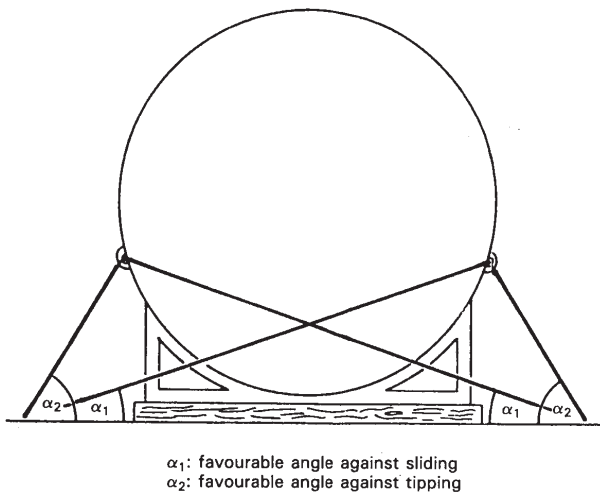

Figure 1 – Securing of portable tanks with favourable lashing angles

6.1.2 Whenever necessary, timber should be used between the deck surface and the bottom structure of the portable tank in order to increase friction. This does not apply to tanks on wooden units or with similar bottom material having a high coefficient of friction.

6.1.3 If stowage under deck is permitted, the stowage should be such that the portable non-standardized tank can be landed directly on its place and bedding.

6.1.4 Securing points on the tank should be of adequate strength and clearly marked.

Note: Securing points designed for road and rail-transport may not be suitable for transport by sea.

6.1.5 Lashings attached to tanks without securing points should pass around the tank and both ends of the lashing should be secured to the same side of the tank (figure 2).

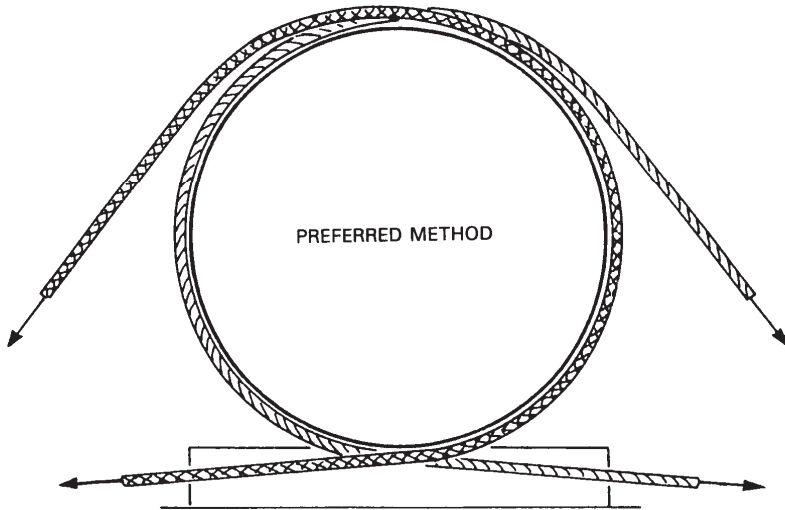

Figure 2 – Securing of portable tanks having no securing points

6.1.6 Sufficient securing devices should be arranged in such a way that each device takes its share of the load with an adequate factor of safety.

6.1.7 The structural strength of the deck or hatch components should be taken into consideration when tanks are carried thereon and when locating and affixing the securing devices.

6.1.8 Portable tanks should be secured in such a manner that no load is imposed on the tank or fittings in excess of those for which they have been designed.

6.2 Standardized portable tanks (tank-containers)

6.2.1 Standardized portable tanks with ISO frame dimensions should be secured according to the system of lashing with which the ship is equipped, taking into consideration the height of the tank above the deck and the ullage in the tank.

7 MAINTENANCE OF SECURING ARRANGEMENTS

7.1 The integrity of the securing arrangements should be maintained throughout the voyage.

7.2 Particular attention should be paid to the need for tight lashings, grips and clips to prevent weakening through chafing.

7.3 Lashings should be regularly checked and retightened.

Annex 3

Safe stowage and securing of portable receptacles***1 INTRODUCTION**

1.1 A portable receptacle, in the context of these guidelines, means a receptacle not being a portable tank, which is not permanently secured on board the ship and has a capacity of 1,000 l or less and has different dimensions in length, width, height and shape and which is used for the transport of gases or liquids.

2 Portable receptacles can be divided into:

- .1 cylinders of different dimensions without securing points and having a capacity not exceeding 150 l;
- .2 receptacles of different dimensions with the exception of cylinders in conformity with 2.1 having a capacity of not less than 100 l and not more than 1,000 l and whether or not fitted with hoisting devices of sufficient strength; and
- .3 assemblies, known as "frames", of cylinders in conformity with 2.1, the cylinders being interconnected by a manifold within the frame and held firmly together by metal fittings. The frames are equipped with securing and handling devices of sufficient strength (e.g. cylindrical receptacles are equipped with rolling hoops and receptacles are secured on skids).

3 CARGO INFORMATION

3.1 The master should be provided with at least the following information:

- .1 dimensions of the receptacle and commodity if non-dangerous and, if dangerous, the information as required in accordance with the IMDG Code;
- .2 gross mass of the receptacles; and
- .3 whether or not the receptacles are equipped with hoisting devices of sufficient strength.

4 STOWAGE

4.1 The typical distribution of accelerations of the ship should be borne in mind in deciding whether the receptacles should be stowed on or under deck.

4.2 The receptacles should preferably be stowed in the fore-and-aft direction on or under deck.

4.3 Receptacles should be dunnaged to prevent their resting directly on a steel deck. They should be stowed and chocked as necessary to prevent movement unless mounted in a frame as a unit. Receptacles for liquefied gases should be stowed in an upright position.

4.4 When the receptacles are stowed in an upright position, they should be stowed in a block, cribbed or boxed in with suitable and sound timber. The box or crib should be dunnaged underneath to provide clearance from a steel deck. The receptacles in a box or crib should be braced to prevent movement. The box or crib should be securely chocked and lashed to prevent movement in any direction.

* Where in this annex the term *receptacle* is used, it is meant to include both receptacles and cylinders.

5 SECURING AGAINST SLIDING AND SHIFTING

5.1 Cylinders

Cylinders should be stowed fore-and-aft on athwartships dunnage. Where practicable, the stow should be secured by using two or more wires, laid athwartships prior to loading, and passed around the stow to securing points on opposite sides. The wires are tightened to make a compact stow by using appropriate tightening devices. During loading, wedges may be necessary to prevent cylinders rolling.

5.2 Cylinders in containers

Cylinders should, whenever practicable, be stowed upright with their valves on top and with their protective caps firmly in place. Cylinders should be adequately secured, so as to withstand the rigours of the intended voyage, by means of steel strapping or equivalent means led to lashing points on the container floor. When cylinders cannot be stowed upright in a closed container, they should be carried in an open top or a platform-based container.

5.3 Receptacles

Securing of receptacles stowed on or under deck should be as follows:

- .1 lashings should be positioned as shown in figure 1;
- .2 where possible, the hoisting devices on receptacles should be used to lash them; and
- .3 at regular times the lashings should be checked and retightened.

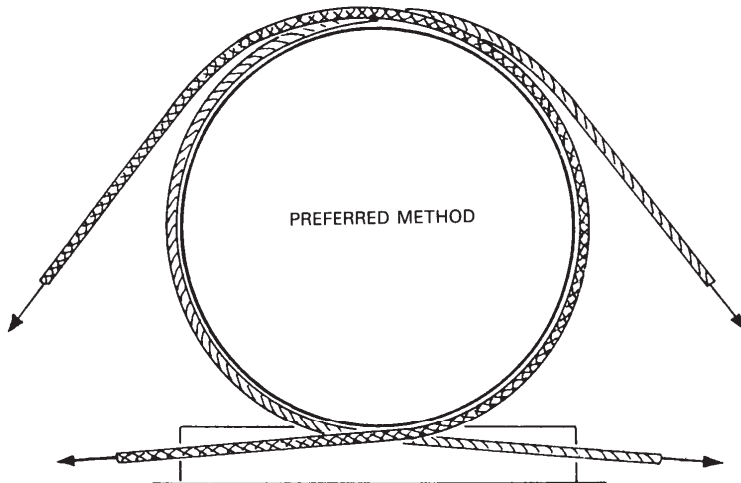

Figure 1 – Securing of receptacles having no securing points

Annex 4

Safe stowage and securing of wheel-based (rolling) cargoes**1 INTRODUCTION**

Wheel-based cargoes, in the context of these guidelines, are all cargoes which are provided with wheels or tracks, including those which are used for the stowage and transport of other cargoes, except trailers and road-trains (covered by chapter 4 of this Code), but including buses, military vehicles with or without tracks, tractors, earth-moving equipment, roll-trailers, etc.

2 GENERAL RECOMMENDATIONS

2.1 The cargo spaces in which wheel-based cargo is to be stowed should be dry, clean and free from grease and oil.

2.2 Wheel-based cargoes should be provided with adequate and clearly marked securing points or other equivalent means of sufficient strength to which lashings may be applied.

2.3 Wheel-based cargoes which are not provided with securing points should have those places, where lashings may be applied, clearly marked.

2.4 Wheel-based cargoes, which are not provided with rubber wheels or tracks with friction-increasing lower surface, should always be stowed on wooden dunnage or other friction-increasing material such as soft boards, rubber mats, etc.

2.5 When in stowage position, the brakes of a wheel-based unit, if so equipped, should be set.

2.6 Wheel-based cargoes should be secured to the ship by lashings made of material having strength and elongation characteristics at least equivalent to steel chain or wire.

2.7 Where possible, wheel-based cargoes, carried as part cargo, should be stowed close to the ship's side or in stowage positions which are provided with sufficient securing points of sufficient strength, or be block-stowed from side to side of the cargo space.

2.8 To prevent any lateral shifting of wheel-based cargoes not provided with adequate securing points, such cargoes should, where practicable, be stowed close to the ship's side and close to each other, or be blocked off by other suitable cargo units such as loaded containers, etc.

2.9 To prevent the shifting of wheel-based cargoes, it is, where practicable, preferable to stow those cargoes in a fore-and-aft direction rather than athwartships. If wheel-based cargoes are inevitably stowed athwartships, additional securing of sufficient strength may be necessary.

2.10 The wheels of wheel-based cargoes should be blocked to prevent shifting.

2.11 Cargoes stowed on wheel-based units should be adequately secured to stowage platforms or, where provided with suitable means, to its sides. Any movable external components attached to a wheel-based unit, such as derricks, arms or turrets should be adequately locked or secured in position.

Annex 5

Safe stowage and securing of heavy cargo items such as locomotives, transformers, etc.

1 CARGO INFORMATION

The master should be provided with sufficient information on any heavy cargo offered for shipment so that he can properly plan its stowage and securing; the information should at least include the following:

- .1 gross mass;
- .2 principal dimensions with drawings or pictorial descriptions, if possible;
- .3 location of the centre of gravity;
- .4 bedding areas and particular bedding precautions if applicable;
- .5 lifting points or slinging positions; and
- .6 securing points, where provided, including details of their strength.

2 LOCATION OF STOWAGE

2.1 When considering the location for stowing a heavy cargo item, the typical distribution of accelerations on the ship should be kept in mind:

- .1 lower accelerations occur in the midship sections and below the weather deck; and
- .2 higher accelerations occur in the end sections and above the weather deck.

2.2 When heavy items are to be stowed on deck, the expected "weather side" of the particular voyage should be taken into account if possible.

2.3 Heavy items should preferably be stowed in the fore-and-aft direction.

3 DISTRIBUTION OF WEIGHT

The weight of the item should be distributed in such a way as to avoid undue stress on the ship's structure. Particularly with the carriage of heavy items on decks or hatch covers, suitable beams of timber or steel of adequate strength should be used to transfer the weight of the item on to the ship's structure.

4 SECURING AGAINST SLIDING AND TIPPING

4.1 Whenever possible, timber should be used between the stowage surface and the bottom of the unit in order to increase friction. This does not apply to items on wooden cradles or on rubber tyres or with similar bottom material having a high coefficient of friction.

4.2 The securing devices should be arranged in a way to withstand transverse and longitudinal forces which may give rise to sliding or tipping.

4.3 The optimum lashing angle against sliding is about 25°, while the optimum lashing angle against tipping is generally found between 45° and 60° (figure 1).

4.4 If a heavy cargo item has been dragged into position on greased skid boards or other means to reduce friction, the number of lashings used to prevent sliding should be increased accordingly.

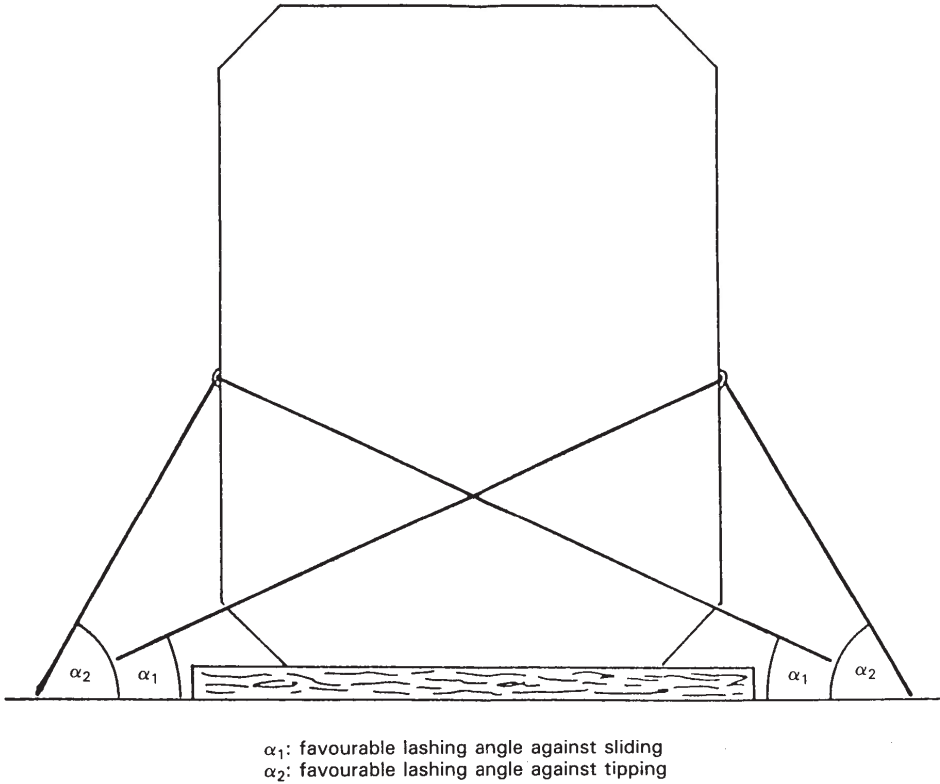

Figure 1 – Principles of securing heavy items against sliding and tipping

4.5 If, owing to circumstances, lashings can be set at large angles only, sliding must be prevented by timber shoring, welded fittings or other appropriate means. Any welding should be carried out in accordance with accepted hot work procedures.

5 SECURING AGAINST HEAVY SEAS ON DECK

Whilst it is recognized that securing cargo items against heavy seas on deck is difficult, all efforts should be made to secure such items and their supports to withstand such impact and special means of securing may have to be considered.

6 HEAVY CARGO ITEMS PROJECTING OVER THE SHIP'S SIDE

Items projecting over the ship's side should be additionally secured by lashings acting in longitudinal and vertical directions.

7 ATTACHMENT OF LASHINGS TO HEAVY CARGO ITEMS

7.1 If lashings are to be attached to securing points on the item, these securing points should be of adequate strength and clearly marked. It should be borne in mind that securing points designed for road or rail transport may not be suitable for securing the items on board ship.

7.2 Lashings attached to items without securing points should pass around the item, or a rigid part thereof, and both ends of the lashing should be secured to the same side of the unit (figure 2).

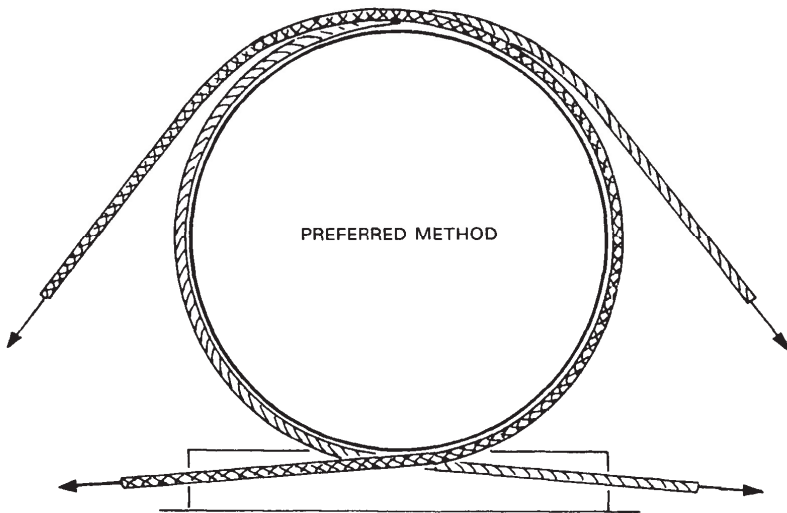

Figure 2 - Principle of securing heavy items having no suitable securing points

8 COMPOSITION AND APPLICATION OF SECURING DEVICES

- 8.1 Securing devices should be assembled so that each component is of equal strength.
- 8.2 Connecting elements and tightening devices should be used in the correct way. Consideration should be given to any reduction of the strength of the lashings during the voyage through corrosion, fatigue or mechanical deterioration and should be compensated by using stronger securing material.
- 8.3 Particular attention should be paid to the correct use of wire, grips and clips. The saddle portion of the clip should be applied to the live load segment and the U-bolt to the dead or shortened end segment.
- 8.4 Securing devices should be arranged in such a way that each device takes its share of load according to its strength.
- 8.5 Mixed securing arrangements of devices with different strength and elongation characteristics should be avoided.

9 MAINTENANCE OF SECURING ARRANGEMENTS

- 9.1 The integrity of the securing arrangements should be maintained throughout the voyage.
- 9.2 Particular attention should be paid to the need for tight lashings, grips and clips and to prevent weakening through chafing. Timber cradles, beddings and shorings should be checked.
- 9.3 Greasing the thread of clips and turnbuckles increases their holding capacity and prevents corrosion.

10 SECURING CALCULATION

- 10.1 Where necessary, the securing arrangements for heavy cargo items should be verified by an appropriate calculation.

Annex 6

Safe stowage and securing of coiled sheet steel

1 GENERAL

1.1 This annex deals only with coiled sheet steel stowed on the round. Vertical stowage is not dealt with because this type of stowage does not create any special securing problems.

1.2 Normally, coils of sheet steel have a gross mass in excess of 10 tonnes each.

2 COILS

2.1 Coils should be given bottom stow and, whenever possible, be stowed in regular tiers from side to side of the ship.

2.2 Coils should be stowed on dunnage laid athwartships. Coils should be stowed with their axes in the fore-and-aft direction. Each coil should be stowed against its neighbour. Wedges should be used as stoppers when necessary during loading and discharging to prevent shifting (figures 1 and 2).

2.3 The final coil in each row should normally rest on the two adjacent coils. The mass of this coil will lock the other coils in the row.

2.4 If it is necessary to load a second tier over the first, then the coils should be stowed in between the coils of the first tier (figure 2).

2.5 Any void space between coils in the topmost tier should be adequately secured (figure 3).

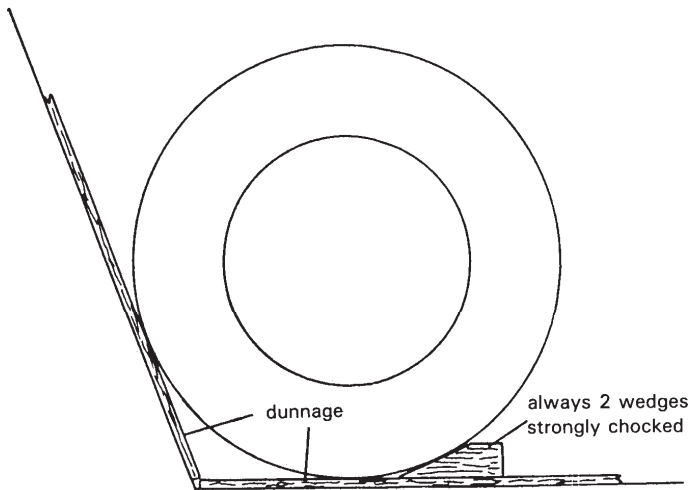

Figure 1 - Principle of dunnaging and wedging coils

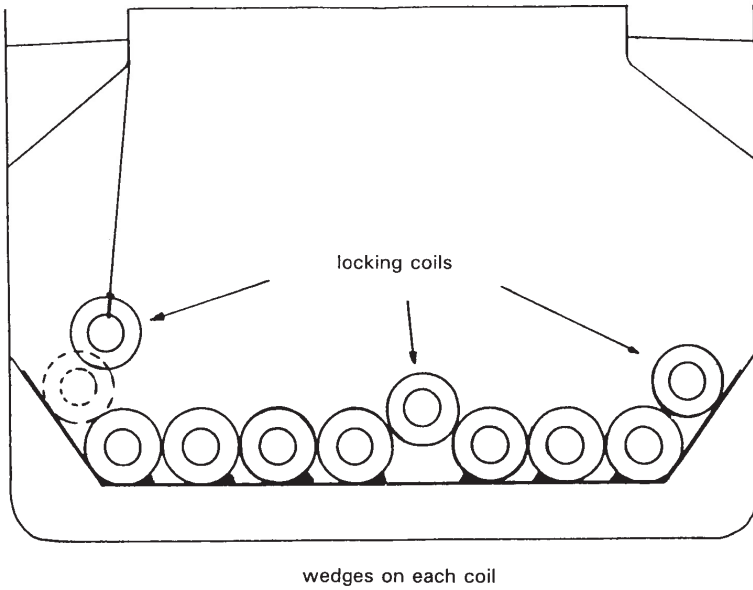

Figure 2 - Inserting of locking coils

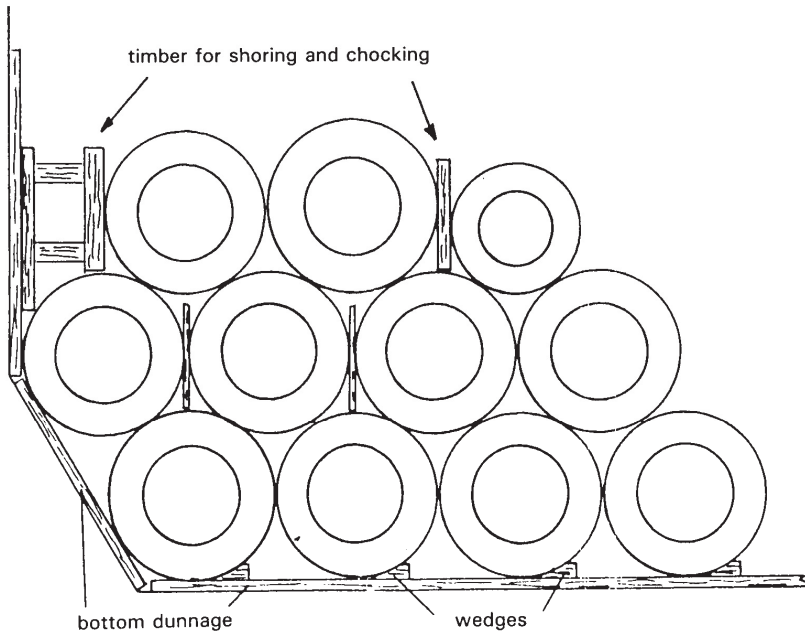

Figure 3 - Shoring and chocking in voids between coils

3 LASHINGS

3.1 The objective is to form one large, immovable block of coils in the hold by lashing them together. In general, strip coils in three end rows in the top tier should be lashed. To prevent fore-and-aft shifting in the top tier of bare-wound coils group-lashing should not be applied due to their fragile nature, the end row of a top tier should be secured by dunnage and wires, which are to be tightened from side to side and by additional wires to the bulkhead. When coils are fully loaded over the entire bottom space and are well shored, no lashings are required except for locking coils (figures 4, 5, and 6).

3.2 The lashings can be of a conventional type using wire or any equivalent means.

3.3 Conventional lashings should consist of wires having sufficient tensile strength. The first tier should be chocked. It should be possible to retighten the lashings during the voyage (figures 5 and 6).

3.4 Wire lashings should be protected against damage from sharp edges.

3.5 If there are few coils, or a single coil only, they should be adequately secured to the ship, by placing them in cradles, by wedging, or by shoring and then lashing to prevent transverse and longitudinal movement.

3.6 Coils carried in containers, railway wagons and road vehicles should be stowed in cradles or specially made beds and should be prevented from moving by adequate securing.

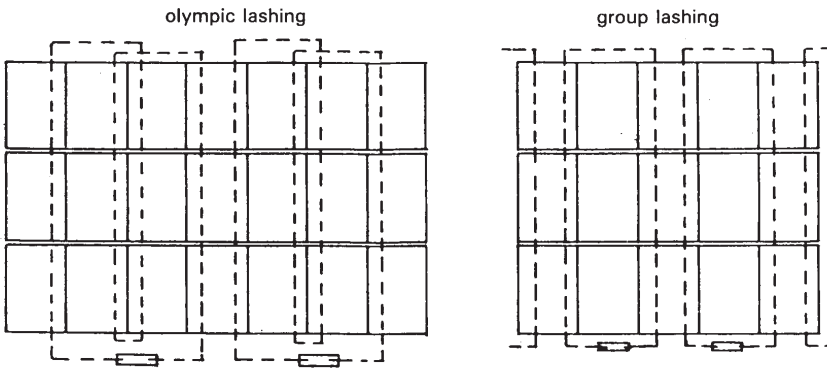

Figure 4 - Securing of top tier against fore-and-aft shifting (view from top)

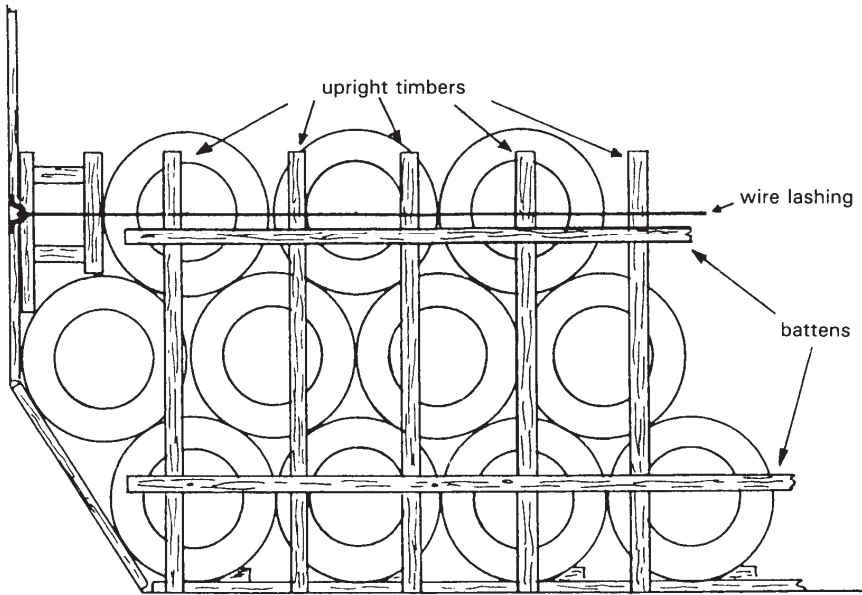

Figure 5 - Securing of end row in top tier against fore-and-aft shifting

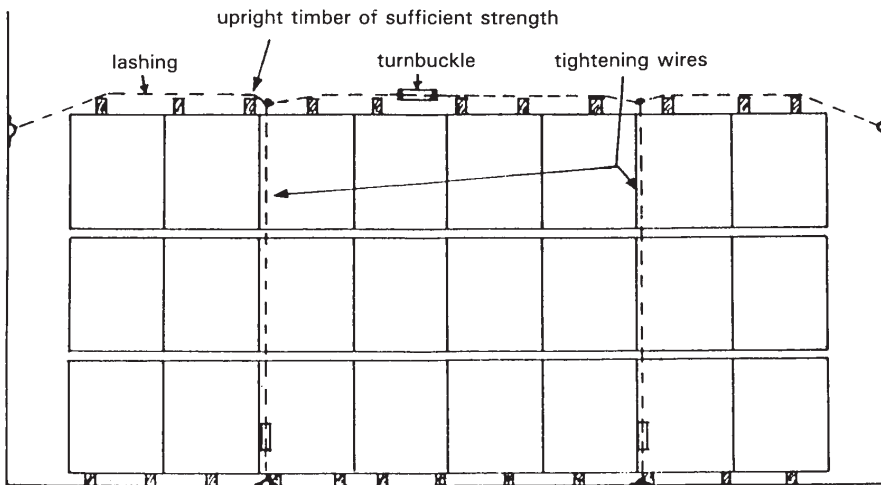

Figure 6 - Securing of end row in top tier against fore-and-aft shifting (view from top)

Annex 7

Safe stowage and securing of heavy metal products

1 GENERAL

1.1 Heavy metal products in the context of this Code include any heavy item made of metal, such as bars, pipes, rods, plates, wire coils, etc.

1.2 The transport of heavy metal products by sea exposes the ship to the following principal hazards:

- .1 overstressing of the ship's structure if the permissible hull stress or permissible deck loading is exceeded;
- .2 overstressing of the ship's structure as a result of a short roll period caused by excessive metacentric height; and
- .3 cargo shifting because of inadequate securing resulting in a loss of stability or damage to the hull or both.

2 RECOMMENDATIONS

2.1 The cargo spaces in which heavy metal products are to be stowed should be clean, dry and free from grease and oil.

2.2 The cargo should be so distributed as to avoid undue hull stress.

2.3 The permissible deck and tank top loading should not be exceeded.

2.4 The following measures should be taken when stowing and securing heavy metal products:

- .1 cargo items should be stowed compactly from one side of the ship to the other leaving no voids between them and using timber blocks between items if necessary;
- .2 cargo should be stowed level whenever possible and practicable;
- .3 the surface of the cargo should be secured; and
- .4 the shoring should be made of strong, non-splintering wood and adequately sized to withstand the acceleration forces. One shoring should be applied to every frame of the ship but at intervals of not less than 1 m.

2.5 In the case of thin plates and small parcels, alternate fore-and-aft and athwartships stowage has proved satisfactory. The friction should be increased by using sufficient dry dunnage or other material between the different layers.

2.6 Pipes, rails, rolled sections, billets, etc., should be stowed in the fore-and-aft direction to avoid damage to the sides of the ship if the cargo shifts.

2.7 The cargo, and especially the topmost layer, can be secured by:

- .1 having other cargo stowed on top of it; or
- .2 lashing by wire, chocking off or similar means.

2.8 Whenever heavy metal products are not stowed from side to side of the ship, special care should be taken to secure such stowages adequately.

2.9 Whenever the surface of the cargo is to be secured, the lashings should be independent of each other, exert vertical pressure on the surface of the cargo, and be so positioned that no part of the cargo is unsecured.

3 WIRE COILS

- 3.1** Wire coils should be stowed flat so that each coil rests against an adjacent coil. The coils in successive tiers should be stowed so that each coil overlaps the coils below.
- 3.2** Wire coils should be tightly stowed together and substantial securing arrangements should be used. Where voids between coils are unavoidable or where there are voids at the sides or ends of the cargo space, the stow should be adequately secured.
- 3.3** When securing wire coils stowed on their sides in several layers like barrels, it is essential to remember that, unless the top layer is secured, the coils lying in the stow can be forced out of the stow by the coils below on account of the ship's motions.

Annex 8

Safe stowage and securing of anchor chains

1 GENERAL

- 1.1** Anchor chains for ships and offshore structures are usually carried in bundles or in continuous lengths.
- 1.2** Provided certain safety measures are followed prior to, during, and after stowage, anchor chains may be lowered directly on to the place of stowage in bundles without further handling or stowed longitudinally either along the ship's entire cargo space or part thereof.
- 1.3** If the cargo plans given in the ship's documentation contain no specific requirements, the cargo should be distributed over the lower hold and 'tween-decks in such a way that stability values thus obtained will guarantee adequate stability.

2 RECOMMENDATIONS

- 2.1** Cargo spaces in which chains are stowed should be clean and free from oil and grease.
- 2.2** Chains should only be stowed on surfaces which are permanently covered either by wooden ceiling or by sufficient layers of dunnage or other suitable friction-increasing materials. Chains should never be stowed directly on metal surfaces.

3 STOWAGE AND SECURING OF CHAINS IN BUNDLES

- 3.1** Chains in bundles, which are lifted directly on to their place of stowage without further handling, should be left with their lifting wires attached and should preferably be provided with additional wires around the bundles for lashing purposes.
- 3.2** It is not necessary to separate layers of chain with friction-increasing material such as dunnage because chain bundles will grip each other. The top layer of chain bundles should be secured to both sides of the ship by suitable lashings. Bundles may be lashed independently or in a group, using the lifting wires.

4 STOWAGE AND SECURING OF CHAINS WHICH ARE STOWED LONGITUDINALLY

4.1 Stowage of each layer of chain should, whenever possible and practicable, commence and terminate close to the ship's side. Care should be taken to achieve a tight stow.

4.2 It is not necessary to separate layers of chain with friction-increasing material, such as dunnage because chain layers will grip each other.

4.3 Bearing in mind the expected weather and sea conditions, the length and nature of the voyage and the nature of the cargo to be stowed on top of the chain, the top layer of each stow should be secured by lashings of adequate strength crossing the stow at suitable intervals and thus holding down the entire stow.

Annex 9

Safe stowage and securing of anchor chains

1 INTRODUCTION

1.1 This annex deals with the stowage of metal scrap which is difficult to stow compactly because of its size, shape and mass, but does not apply to metal scrap such as metal borings, shavings or turnings, the carriage of which is addressed by the Code of Safe Practice for Solid Bulk Cargoes.

1.2 The hazards involved in transporting metal scrap include:

- .1 shifting of the stow which in turn can cause a list;
- .2 shifting of individual heavy pieces which can rupture the side plating below the waterline and give rise to serious flooding;
- .3 excessive loading on tank tops or 'tween-decks; and
- .4 violent rolling caused by excessive metacentric height.

2 RECOMMENDATIONS

2.1 Before loading, the lower battens of the spar ceiling should be protected by substantial dunnage to reduce damage and to prevent heavy and sharp pieces of scrap coming in contact with the ship's side plating. Air and sounding pipes, and bilge and ballast lines protected only by wooden boards, should be similarly protected.

2.2 When loading, care should be taken to ensure that the first loads are not dropped from a height which could damage the tank tops.

2.3 If light and heavy scrap is to be stowed in the same cargo space, the heavy scrap should be loaded first. Scrap should never be stowed on top of metal turnings, or similar forms of waste metal.

2.4 Scrap should be compactly and evenly stowed with no voids or unsupported faces of loosely held scrap.

2.5 Heavy pieces of scrap, which could cause damage to the side plating or end bulkheads if they were to move, should be overstowed or secured by suitable lashings. The use of shoring is unlikely to be effective because of the nature of the scrap.

2.6 Care should be taken to avoid excessive loading on tank tops and decks.

Annex 10

Safe stowage and securing of flexible intermediate bulk containers

1 INTRODUCTION

1.1 A flexible intermediate bulk container (FIBC), in the context of these guidelines, means a flexible portable packaging to be used for the transport of solids with a capacity of not more than 3 m³ (3,000 l) designed for mechanical handling and tested for its satisfactory resistance to transport and transport stresses in a one-way type or multi-purpose design.

2 CARGO INFORMATION

The master should at least be provided with the following information:

- .1 the total number of FIBCs and the commodity to be loaded;
- .2 the dimensions of the FIBCs;
- .3 the total gross mass of the FIBCs;
- .4 one-way type or multi-purpose design; and
- .5 the kind of hoisting (one hook or more hooks to be used).

3 RECOMMENDATIONS

3.1 The ideal ship for the carriage of FIBCs is one with wide hatches so that the FIBCs can be landed directly in the stowage positions without the need for shifting.

3.2 The cargo spaces should, where practicable, be rectangular in shape and free of obstructions.

3.3 The stowage space should be clean, dry and free from oil and nails.

3.4 When FIBCs have to be stowed in deep hatch wings, easy access and sufficient manoeuvring space for suitably adapted fork-lift trucks should be available.

3.5 When FIBCs are stowed in the hatchway only, the space in the wings and the forward and aft end of the cargo space should be loaded with other suitable cargo or blocked off in such a way that the FIBCs are adequately supported.

4 STOWAGE

4.1 The typical distribution of the accelerations of the ship should be kept in mind when FIBCs are loaded.

4.2 The width of the ship divided by the width of the FIBC will give the number of FIBCs which can be stowed athwartships and the void space left. If there will be a void space, the stowage of the FIBCs should start from both sides to the centre, so that any void space will be in the centre of the hatchway.

4.3 FIBCs should be stowed as close as possible against each other and any void space should be chocked off.

4.4 The next layers should be stowed in a similar way so that the FIBCs fully cover the FIBCs underneath. If in this layer a void space is left, it should also be chocked off in the centre of the hatchway.

4.5 When there is sufficient room in the hatchway on top of the layers underneath to stow another layer, it should be established whether the coamings can be used as bulkheads. If not, measures should be taken to prevent the FIBCs shifting to the open space in the wings. Otherwise, the FIBCs should be stowed from one coaming to another. In both cases any void space should be in the centre and should be chocked off.

4.6 Chocking off is necessary in all cases to prevent shifting of the FIBCs to either side and to prevent a list of the ship developing in rough weather (figure 1).

5 SECURING

5.1 In cases where only a part of a 'tween-deck or lower hold is used for the stowage of FIBCs, measures should be taken to prevent the FIBCs from shifting. These measures should include sufficient gratings or plywood sheets placed against the FIBCs and the use of wire lashings from side to side to secure the FIBC cargo.

5.2 The wire lashings and plywood sheets used for securing should be regularly checked, in particular before and after rough weather, and retightened if necessary.

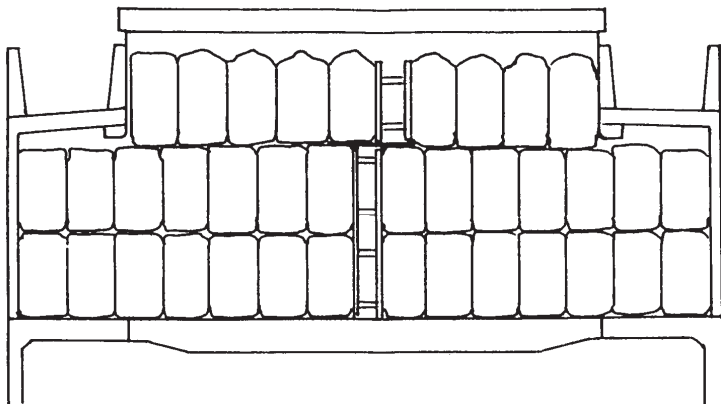

Figure 1 – Stowage of FIBCs with chocked void spaces in the centre of the stowage area

Annex 11

General guidelines for the under-deck stowage of logs

1 INTRODUCTION

The purpose of this annex is to recommend safe practices for the under-deck stowage of logs and other operational safety measures designed to ensure the safe transport of such cargoes.

2 Prior to loading:

- .1 each cargo space configuration (length, breadth and depth), the cubic bale capacity of the respective cargo spaces, the various lengths of logs to be loaded, the cubic volume (log average), and the capacity of the gear to be used to load the logs should be determined;

- .2 using the above information, a pre-stow plan should be developed to allow the maximum utilization of the available space; the better the under-deck stowage, the more cargo can safely be carried on deck;
 - .3 the cargo spaces and related equipment should be examined to determine whether the condition of structural members, framework and equipment could affect the safe carriage of the log cargo. Any damage discovered during such an examination should be repaired in an appropriate manner;
 - .4 the bilge suction screens should be examined to ensure they are clean, effective and properly maintained to prevent the admission of debris into the bilge piping system;
 - .5 the bilge wells should be free of extraneous material such as wood bark and wood splinters;
 - .6 the capacity of the bilge pumping system should be ascertained. A properly maintained and operating system is crucial for the safety of the ship. A portable dewatering pump of sufficient capacity and lift will provide additional insurance against a clogged bilge line;
 - .7 side sparring, pipe guards, etc., designed to protect internal hull members should be in place; and
 - .8 the master should ensure that the opening and closing of any high ballast dump valves are properly recorded in the ship's log. Given that such high ballast tanks are necessary to facilitate loading and bearing in mind regulation 22(1) of the International Convention on Load Lines, 1966, which requires a screw-down valve fitted in gravity overboard drain lines, the master should ensure that the dump valves are properly monitored to preclude the accidental readmission of water into these tanks. Leaving these tanks open to the sea, could lead to an apparently inexplicable list, a shift of deck cargo, and potential capsizing.
- 3 During loading operations:
- .1 each lift of logs should be hoisted aboard the ship in close proximity to the ship to minimize any potential swinging of the lift;
 - .2 the possibility of damage to the ship and the safety of those who work in the cargo spaces should be considered. The logs should not be swinging when lowered into the space. The hatch coaming should be used, as necessary, to eliminate any swinging of the logs by gently resting the load against the inside of the coaming, or on it, prior to lowering;
 - .3 the logs should be stowed compactly, thereby eliminating as many voids as is practicable. The amount and the vertical centre of gravity of the logs stowed under deck will govern the amount of cargo that can be safely stowed on deck. In considering this principle, the heaviest logs should be loaded first into the cargo spaces;
 - .4 logs should generally be stowed compactly in a fore and aft direction, with the longer lengths towards the forward and aft areas of the space. If there is a void in the space between the fore and aft lengths, it should be filled with logs stowed athwartships so as to fill in the void across the breadth of the spaces as completely as the length of the logs permits;
 - .5 where the logs in the spaces can only be stowed fore and aft in one length, any remaining void forward or aft should be filled with logs stowed athwartships so as to fill in the void across the breadth of the space as completely as the length of the logs permits;
 - .6 athwartship voids should be filled tier by tier as loading progresses;
 - .7 butt ends of the logs should be alternately reversed to achieve a more level stowage, except where excess sheer on the inner bottom is encountered;
 - .8 extreme pyramiding of logs should be avoided to the greatest extent possible. If the breadth of the space is greater than the breadth of the hatch opening, pyramiding may be avoided by sliding fore and aft loaded logs into the ends of the port and starboard sides of the space. This sliding of logs into the ends of the port and starboard sides of the space should

commence early in the loading process (after reaching a height of approximately 2 m above the inner bottom) and should continue throughout the loading process;

- .9 it may be necessary to use loose tackle to manoeuvre heavy logs into the under-deck areas clear of the hatchways. Blocks, purchases and other loose tackle should be attached to suitably reinforced fixtures such as eyebolts or padeyes provided for this purpose. However, if this procedure is followed, care should be taken to avoid overloading the gear;
- .10 a careful watch by ship's personnel should be maintained throughout the loading to ensure no structural damage occurs. Any damage which affects the seaworthiness of the ship should be repaired;
- .11 when the logs are stowed to a height of about 1 m below the forward or aft athwartship hatch coaming, the size of the lift of logs should be reduced to facilitate stowing of the remaining area; and
- .12 logs in the hatch coaming area should be stowed as compactly as possible to maximum capacity.

4 After loading, the ship should be thoroughly examined to ascertain its structural condition. Bilges should be sounded to verify the ship's watertight integrity.

5 During the voyage:

- .1 the ship's heeling angle and rolling period should be checked, in a seaway, on a regular basis;
- .2 wedges, wastes, hammers and portable pump, if provided, should be stored in an easily accessible place; and
- .3 the master or a responsible officer should ensure that it is safe to enter an enclosed cargo space by:
 - .3.1 ensuring that the space has been thoroughly ventilated by natural or mechanical means;
 - .3.2 testing the atmosphere of the space at different levels for oxygen deficiency and harmful vapour where suitable instruments are available; and
 - .3.3 requiring self-contained breathing apparatus to be worn by all persons entering the space where there is any doubt as to the adequacy of ventilation or testing before entry.

Annex 12

Safe stowage and securing of unit loads

1 INTRODUCTION

Unit load for the purposes of this annex means that a number of packages are either:

- .1 placed or stacked, and secured by strapping, shrink-wrapping or other suitable means, on a load board such as a pallet; or
- .2 placed in a protective outer packaging such as a pallet box; or
- .3 permanently secured together in a sling.

Note: A single large package such as a portable tank or receptacle, intermediate bulk container or freight container is excluded from the recommendations of this annex.

2 CARGO INFORMATION

The master should be provided with at least the following information:

- .1 the total number of unit loads and commodity to be loaded;
- .2 the type of strapping or wrapping used;
- .3 the dimensions of a unit load in metres; and
- .4 the gross mass of a unit load in kilogrammes.

3 RECOMMENDATIONS

3.1 The cargo spaces of the ship in which unit loads will be stowed should be clean, dry and free from oil and grease.

3.2 The decks, including the tank top, should be flush all over.

3.3 The cargo spaces should preferably be of a rectangular shape, horizontally and vertically. Cargo spaces of another shape in forward holds or in 'tweendecks should be transformed into a rectangular shape both athwartships and longitudinally by the use of suitable timber (figure 1).

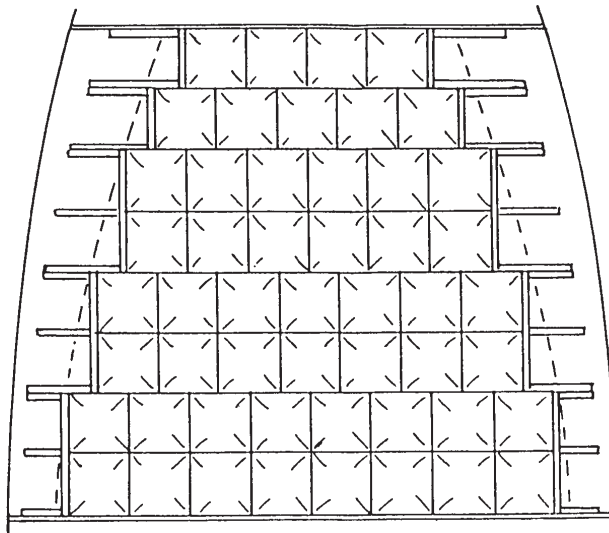

Figure 1 – Stowage and chocking of unit loads in a tapered stowage area (view from top)

4 STOWAGE

4.1 The unit loads should be stowed in such a way that securing, if needed, can be performed on all sides of the stow.

4.2 The unit loads should be stowed without any void space between the loads and the ship's sides to prevent the unit loads from racking.

4.3 When unit loads have to be stowed on top of each other, attention should be paid to the strength of pallets and the shape and the condition of the unit loads.

4.4 Precautions should be taken when unit loads are mechanically handled to avoid damaging the unit loads.

5 SECURING

Block stowage should be ensured and no void space be left between the unit loads.

6 SECURING WHEN STOWED ATHWARTSHIPS

6.1 When unit loads are stowed in a lower hold or in a 'tween-deck against a bulkhead from side to side, gratings or plywood sheets should be positioned vertically against the stack of the unit loads. Wire lashings should be fitted from side to side keeping the gratings or plywood sheets tight against the stow.

6.2 Additionally, lashing wires can be fitted at different spacing from the bulkhead over the stow to the horizontally placed wire lashings in order to further tighten the stow.

7 STOWAGE IN A WING OF A CARGO SPACE AND FREE AT TWO SIDES

When unit loads are stowed in the forward or after end of a cargo space and the possibility of shifting in two directions exists, gratings or plywood sheets should be positioned vertically to the stack faces of the unit loads of the non-secured sides of the stow. Wire lashings should be taken around the stow from the wings to the bulkhead. Where the wires can damage the unit loads (particularly on the corners of the stow), gratings or plywood sheets should be positioned in such a way that no damage can occur on corners.

8 STOWAGE FREE AT THREE SIDES

When unit loads are stowed against the ship's sides in such a way that shifting is possible from three sides, gratings or plywood sheets should be positioned vertically against the stack faces of the unit loads. Special attention should be paid to the corners of the stow to prevent damage to the unit loads by the wire lashings. Wire lashing at different heights should tighten the stow together with the gratings or plywood sheets at the sides (figure 2).

9 GENERAL

9.1 Instead of gratings or plywood sheets, other possibilities are the use of aluminium stanchions or battens of sufficient strength.

9.2 During the voyage the wire lashings should be regularly inspected and slack wires should be retightened if necessary. In particular, after rough weather, wire lashings should be checked and retightened if necessary.

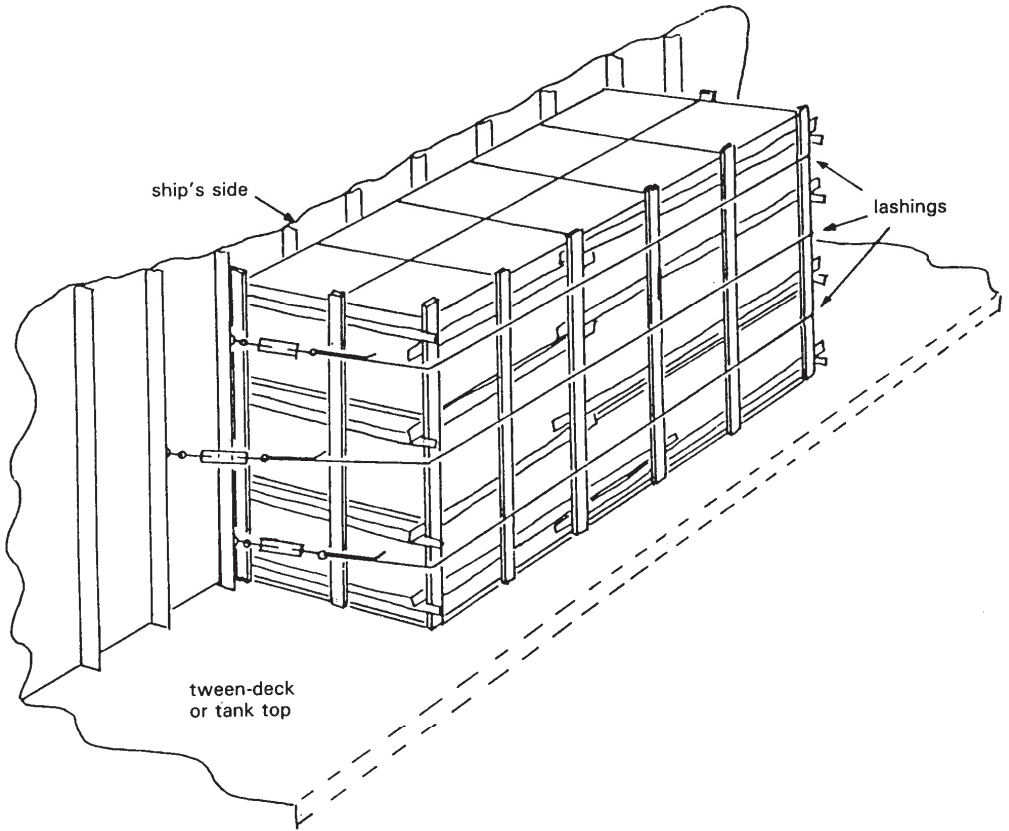

Figure 2 – Securing of units stowed at the ship's side

INTERNATIONAL MARITIME ORGANIZATION

4 ALBERT EMBANKMENT
LONDON SE1 7SR

Telephone: 071-735 7611
Telegrams: INTERMAR-LONDON SE1
Telex: 23588
Telefax: 071-587 3210



MSC/Circ.664
22 December 1994

Ref. T3/2.04

CONTAINERS AND CARGOES

**CODE OF SAFE PRACTICE FOR CARGO STOWAGE AND
SECURING (CSS CODE)**

Amendments to the CSS Code

1 The Maritime Safety Committee, at its sixty-fourth session (5 to 9 December 1994), adopted, in accordance with operative paragraph 3 of Assembly resolution A.714(17), the annexed amendments to the Code of Safe Practice for Cargo Stowage and Securing (CSS Code).

2 Member Governments are invited to bring the said amendments to the attention of shipowners, ship operators, shipmasters and crews and all others concerned.

ANNEX

**AMENDMENTS TO THE CODE OF SAFE PRACTICE
FOR CARGO STOWAGE AND SECURING**

- 1 Replace the first sentence of paragraph 1.9.1 of chapter 1 by:

"Prior to shipment the shipper should provide all necessary information about the cargo to enable the shipowner or ship operator to ensure that."
- 2 Replace paragraph 2.9.1 of chapter 2 by:

"2.9.1 Where there is reason to suspect that a container or vehicle into which dangerous goods have been packed or loaded is not in compliance with the provisions of regulation VII/5.2 or 5.3 of SOLAS 1974, as amended, or with the provisions of section 12 or 17, as appropriate, of the General Introduction to the IMDG Code, or where a container packing certificate/vehicle packing declaration is not available, the unit should not be accepted for shipment."
- 3 Replace paragraph 3.2 of annex 6 by:

"3.2 The lashings can be of a conventional type using wire, steel band or any equivalent means."
- 4 Add a new annex 13, as shown in the appendix.

APPENDIX

Annex 13

Methods to assess the efficiency of securing arrangements for non-standardized cargo

1. SCOPE OF APPLICATION

The methods described in this annex should be applied to non-standardized cargoes, but not to containers on containerhips .

Very heavy units as carried under the provisions of Chapter 1.8 of the Code of Safe Practice for Cargo Stowage and Securing (the Code) and those items for which exhaustive advice on stowage and securing is given in the annexes to the Code should be excluded.

Nothing in this annex should be read to exclude the use of computer software, provided the output achieves design parameters which meet the minimum safety factors applied in this annex.

The application of the methods described in this annex are supplementary to the principles of good seamanship and shall not replace experience in stowage and securing practice.

2. PURPOSE OF THE METHODS

The methods should:

- .1 provide guidance for the preparation of the Cargo Securing Manual and the examples therein;
- .2 assist ship's staff in assessing the securing of cargo units not covered by the Cargo Securing Manual;
- .3 assist qualified shore personnel in assessing the securing of cargo units not covered by the Cargo Securing Manual; and
- .4 serve as a reference for maritime and port related education and training.

3. PRESENTATION OF THE METHODS

The methods are presented in a universally applicable and flexible way. It is recommended that designers of Cargo Securing Manuals convert this presentation into a form suiting the particular ship, its securing equipment and the cargo carried. This form may consist of applicable diagrammes, tables or calculated examples.

4. STRENGTH OF SECURING EQUIPMENT

- .1 Manufacturers of securing equipment should at least supply information on the nominal breaking strength of the equipment in kilo-Newton (kN) ¹⁾.
- .2 "Maximum Securing Load" (MSL) is a term used to define the load capacity for a device used to secure cargo to a ship. Maximum securing load is to securing devices as safe working load is to lifting tackle. The MSL for different securing devices are given below if not given under 4.3. The MSL of timber should be taken as 0.3 kN per cm² normal to the grain.

Material	MSL
shackles, rings, deckeyes, turnbuckles of mild steel	50% of breaking strength
fibre rope	33% of breaking strength
wire rope (single use)	80% of breaking strength
wire rope (re-usable)	30% of breaking strength
steel band (single use)	70% of breaking strength
chains	50% of breaking strength

Table 1: Determination of MSL from breaking strength

¹⁾ 1 kN = 100 kg

- 3 For particular securing devices (e.g. fibre straps with tensioners or special equipment for securing containers) a permissible working load may be prescribed and marked by authority. This should be taken as the MSL.
- 4 When the components of a lashing device are connected in series, for example, a wire to a shackle to a deck eyes, the minimum MSL in the series shall apply to that device.

5. SAFETY FACTOR

Within the assessment of a securing arrangement by a calculated balance of forces and moments the calculation strength of securing devices (CS) should be reduced against MSL using a safety factor of 1.5 as follows:

$$CS = \frac{MSL}{1.5}$$

The reasons for this reduction are the possibility of uneven distribution of forces among the devices, strength reduction due to poor assembly and others.

Notwithstanding the introduction of such a safety factor, care should be taken to use securing elements of similar material and strength in order to provide a uniform elastic behavior within the arrangement.

RULE-OF-THUMB METHOD

The total of MSL values of the securing devices on each side of a unit of cargo (port as well as starboard) should equal the weight of the unit ².

This method, which implies a transverse acceleration of 1 g (9.81 m/sec²), applies to nearly any size of ships regardless of the location of stowage, stability and loading conditions, season and area of operation. The method however, neither takes into account the adverse effects of lashing angles and non-homogeneous distribution of forces among the securing devices nor the favourable effect of friction.

Transverse lashing angles to the deck should not be greater than 60° and it is important that adequate friction is provided by the use of suitable material. Additional lashings at angles of greater than 60° may be desirable to prevent tipping but are not to be counted in the number of lashings under the rule-of-thumb.

ADVANCED CALCULATION METHOD

1 Assumption of external forces

External forces to a cargo unit in longitudinal, transverse and vertical direction should be obtained using the formula:

$$F_{(x,y,z)} = m \cdot a_{(x,y,z)} + F_{w(x,y)} + F_{s(x,y)}$$

$F_{(x,y,z)}$ = longitudinal, transverse and vertical forces

m = mass of the unit

$a_{(x,y,z)}$ = longitudinal, transverse and vertical acceleration (see table 2)

$F_{w(x,y)}$ = longitudinal and transverse force by wind pressure

$F_{s(x,y)}$ = longitudinal and transverse force by sea sloshing.

²: basic acceleration data are presented in Table 2.

² The weight of the unit should be taken in kN

Transverse acceleration a_y in m/sec^2										Longitudinal acceleration a_x in m/sec^2	
on deck high	7.1	6.9	6.8	6.7	6.7	6.8	6.9	7.1	7.4	3.8	
on deck low	6.5	6.3	6.1	6.1	6.1	6.1	6.3	6.5	6.7	2.9	
tween deck	5.9	5.6	5.5	5.4	5.4	5.5	5.6	5.9	6.2	2.0	
lower hold	5.5	5.3	5.1	5.0	5.0	5.1	5.3	5.5	5.9	1.5	
	0	0.1	0.2	0.3	0.4	0.5	0.6	0.7	0.8	0.9	L
Vertical acceleration a_z in m/sec^2											
	7.6	6.2	5.0	4.3	4.3	5.0	6.2	7.6	9.2		

Table 2: Basic acceleration data

Remarks:

The given transverse acceleration figures include components of gravity, pitch and heave parallel to the deck. The given vertical acceleration figures do not include the static weight component.

The basic acceleration data are to be considered as valid under the following operational conditions:

1. Operation in unrestricted area.
2. Operation during the whole year.
3. Duration of the voyage is 25 days.
4. Length of the ship is 100 m.
5. Service speed is 15 knots.
6. $B/GM \geq 13$. (B: breadth of ship, GM: metacentric height)

For operation in a restricted area reduction of these figures may be considered taking also into account the season of the year and the duration of the voyage.

For ships of a length other than 100 m and a service speed other than 15 knots the acceleration figures should be corrected by a factor given in Table 3.

Length	50	60	70	80	90	100	120	140	160	180	200
Speed											
9 kn	1.20	1.09	1.00	0.92	0.85	0.79	0.70	0.63	0.57	0.53	0.49
12 kn	1.34	1.22	1.12	1.03	0.96	0.90	0.79	0.72	0.65	0.60	0.56
15 kn	1.49	1.36	1.24	1.15	1.07	1.00	0.89	0.80	0.73	0.68	0.63
18 kn	1.64	1.49	1.37	1.27	1.18	1.10	0.98	0.89	0.82	0.76	0.71
21 kn	1.78	1.62	1.49	1.38	1.29	1.21	1.08	0.98	0.90	0.83	0.78
24 kn	1.93	1.76	1.62	1.50	1.40	1.31	1.17	1.07	0.98	0.91	0.85

Table 3: Correction factors for length and speed

In addition for ships with B/GM less than 13, the transverse acceleration figures should be corrected by a factor given in Table 4.

B/GM	7	8	9	10	11	12	13 or above
on deck high	1.56	1.40	1.27	1.19	1.11	1.05	1.00
on deck low	1.42	1.30	1.21	1.14	1.09	1.04	1.00
tween deck	1.26	1.19	1.14	1.09	1.06	1.03	1.00
lower hold	1.15	1.12	1.09	1.06	1.04	1.02	1.00

Table 4: Correction factors for B/GM < 13

The following cautions should be observed:

In the case of marked roll resonance with amplitudes above $\pm 30^\circ$, the given figures of transverse acceleration may be exceeded. Effective measures should be taken to avoid this condition.

In case of heading the seas at high speed with marked slamming shocks, the given figures of longitudinal and vertical acceleration may be exceeded. An appropriate reduction of speed should be considered.

In the case of running before large stern or aft quartering seas with a stability, which does not amply exceed the accepted minimum requirements, large roll amplitudes must be expected with transverse accelerations greater than the figures given. An appropriate change of heading should be considered.

Forces by wind and sea to cargo units above the weather deck should be accounted for by a simple approach:

- force by wind pressure = 1 kN per m²
- force by sea sloshing = 1 kN per m².

Sloshing by sea can induce forces much greater than the figure given above. This figure should be considered as remaining unavoidable after adequate measures to prevent overcoming seas.

Sea sloshing forces need only be applied to a height of deck cargo up to 2 metres above the weather deck or hatch top.

For voyages in restricted area sea sloshing forces may be neglected.

7.2 Balance of forces and moments

The balance calculation should preferably be carried out for

- transverse sliding in port and starboard direction
- transverse tipping in port and starboard direction
- longitudinal sliding under conditions of reduced friction in forward and aft direction.

In case of symmetrical securing arrangements one appropriate calculation is sufficient.

7.2.1 Transverse sliding

The balance calculation should meet the following condition (see also Fig. 1):

$$F_y \leq \mu \cdot m \cdot g + CS_1 \cdot f_1 + CS_2 \cdot f_2 + \dots + CS_n \cdot f_n$$

where

- n is the number of lashings being calculated
- F_y is transverse force from load assumption (kN)
- μ is friction coefficient
($\mu = 0.3$ for steel-timber or steel-rubber)
($\mu = 0.1$ for steel-steel dry)
($\mu = 0.0$ for steel-steel wet)

MSC/Circ.664
ANNEX
Page 6

- m is mass of cargo unit (t)
- g is gravity acceleration of earth = 9.81 (m/s²)
- CS is calculated strength of transverse securing devices (kN)
- f is function of μ and vertical securing angle α (see Table 5).

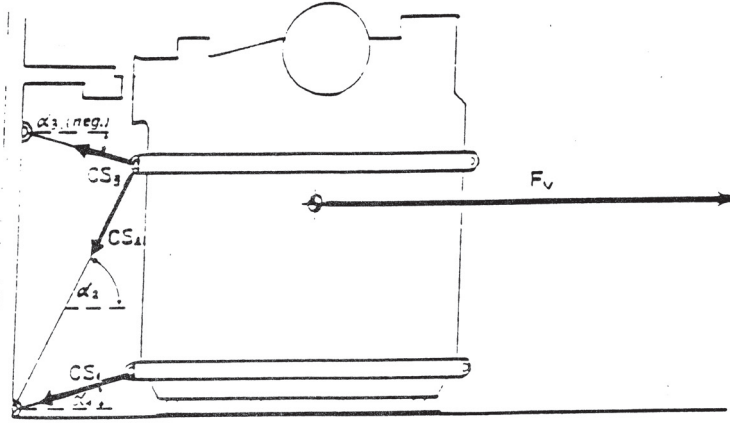

Figure 1: Balance of transverse forces

A vertical securing angle α greater than 60° will reduce the effectiveness of this particular securing device in respect to sliding of the unit. Disregarding of such devices from the balance of forces should be considered, unless the necessary load is gained by the imminent tendency to tipping or by a reliable pretensioning of the securing device which includes maintaining the pretension throughout the voyage.

Any horizontal securing angle, i.e. deviation from the transverse direction, should not exceed 30°, otherwise an exclusion of this securing device from the transverse sliding balance should be considered.

$\mu \backslash \alpha$	- 30°	- 20°	- 10°	0°	10°	20°	30°	40°	50°	60°	70°	80°	90°
0.3	0.72	0.84	0.93	1.00	1.04	1.04	1.02	0.96	0.87	0.76	0.62	0.47	0.30
0.1	0.82	0.91	0.97	1.00	1.00	0.97	0.92	0.83	0.72	0.59	0.44	0.27	0.10
0.0	0.87	0.94	0.98	1.00	0.98	0.94	0.87	0.77	0.64	0.50	0.34	0.17	0.00

Table 5: f-values as function of α and μ / Remark: $f = \mu \cdot \sin \alpha + \cos \alpha$

7.2.2 Transverse tipping

This balance calculation should meet the following condition (see also Fig. 2):

$$F_y \cdot a \leq b \cdot m \cdot g + CS_1 \cdot c_1 + CS_2 \cdot c_2 + \dots + CS_n \cdot c_n$$

where

- F_y, m, g, CS, n are as explained under 7.2.1.
- a is lever-arm of tipping (m) (see Fig. 2)
- b is lever-arm of stability (m) (see Fig. 2)
- c is lever-arm of securing force (m) (see Fig. 2)

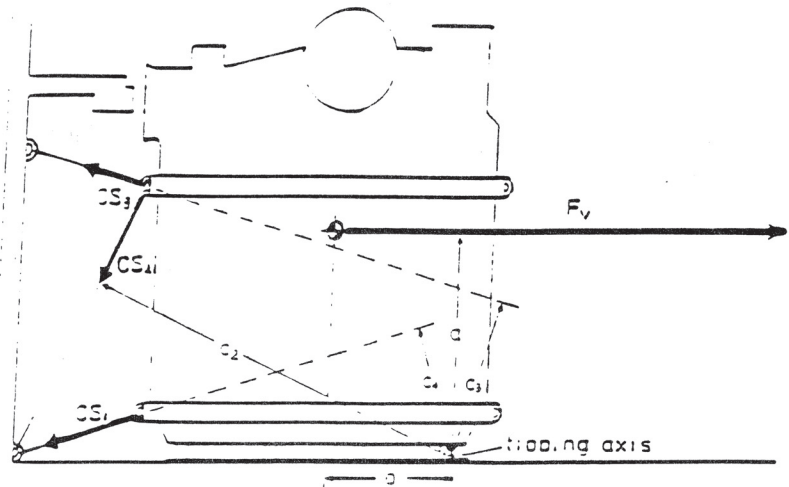

Figure 2: Balance of transverse moments

7.2.3 Longitudinal sliding

Under normal conditions the transverse securing devices provide sufficient longitudinal components to prevent longitudinal sliding. If in doubt, a balance calculation should meet the following condition:

$$F_x \leq \mu \cdot (m \cdot g - F_z) + CS_1 \cdot f_1 + CS_2 \cdot f_2 + \dots + CS_n \cdot f_n$$

where

F_x	is	longitudinal force from load assumption (kN)
n, μ, m, g	are	as explained under 7.2.1
F_z	is	vertical force from load assumption (kN)
CS	is	calculated strength of longitudinal securing devices (kN)

Remark: Longitudinal components of transverse securing devices should not be assumed greater than $0.5 \cdot CS$.

MSC/Circ.664
ANNEX
Page 8

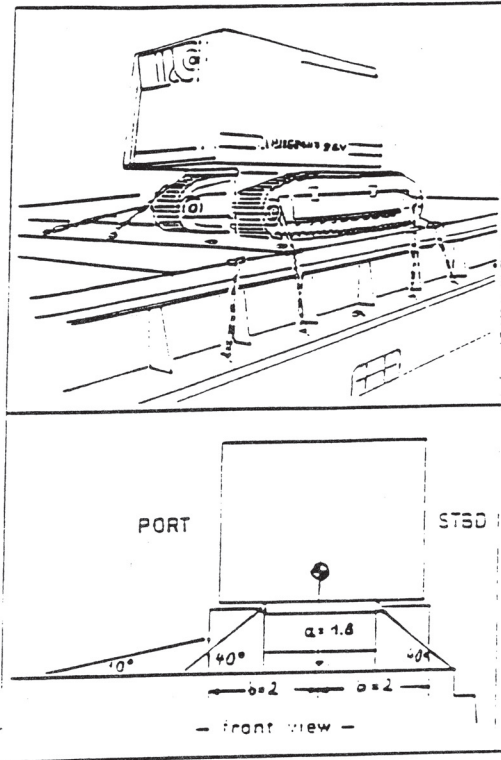

Advanced Calculation Method
Calculated Example

Ship: L = 120 m; B = 20 m; GM = 1.4 m
Speed = 15 knots

Cargo: m = 62 t; dimensions = 6·4·4 m
Stowage at 0.7 L on deck low

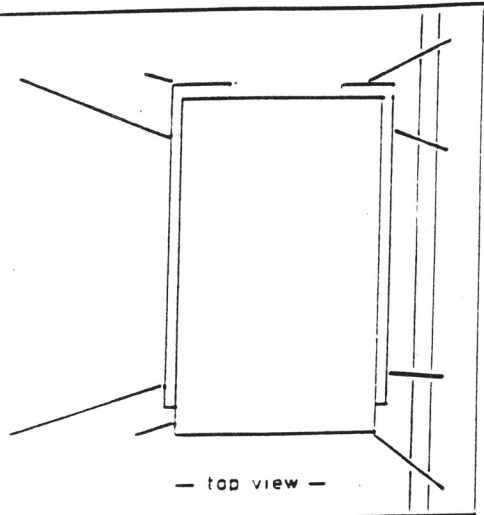

Securing material: wire rope: br. strength = 125 kN; MSL = 100 kN
shackles, turnbuckles, deck rings: ... br. strength = 180 kN; MSL = 90 kN
stowed on dunnage-boards: $\mu = 0.3$; CS = $90/1.5 = 60$ kN

Securing arrangement:

side	n	CS	α	f	c
STBD	4	60 kN	40°	0.96	-
PORT	2	60 kN	40°	0.96	-
PORT	2	60 kN	10°	1.04	-

External forces:
 $F_x = 2.9 \cdot 0.89 \cdot 62 = 16 - 3 = 184$ kN
 $F_y = 6.3 \cdot 0.89 \cdot 62 = 24 - 12 = 384$ kN
 $F_z = 6.2 \cdot 0.89 \cdot 62 = 342$ kN

Balance of forces (STBD-arrangement):
 $384 < 0.3 \cdot 62 \cdot 9.81 + 4 \cdot 60 \cdot 0.96$
 $384 < 412$ this is ok!

Balance of forces (PORT-arrangement):
 $384 < 0.3 \cdot 62 \cdot 9.81 + 2 \cdot 60 \cdot 0.96 + 2 \cdot 60 \cdot 1.04$
 $384 < 422$ this is ok!

Balance of moments:
 $384 \cdot 1.8 < 2 \cdot 62 \cdot 9.81$
 $691 < 1216$ no tipping, even without lashings!

Explanations and interpretation to the "Methods to assess the efficiency of securing arrangements for non-standardized cargo"

1. The exclusion from the scope of application of the methods of very heavy units as carried under the provisions of Chapter 1.8 of the Code should be understood to accommodate the possibility of adapting the stowage and securing of such units to specifically determined weather- and sea-conditions during transport. The exclusion should not be understood as restriction of the methods to units up to a certain mass or dimension.
2. The acceleration figures given in Table 2 in combination with the correction factors represent peak values on a 25-day voyage. This does not imply that peak values in x-, y- and z-direction occur simultaneously with the same probability. It can be generally assumed that peak values in the transverse direction will appear in combination with less than 60% of the peak values in longitudinal and vertical direction.

Peak values in longitudinal and vertical direction may join more closely because they have the common source of pitching and heaving.
3. The advanced calculation method uses the "worst case approach". That is expressed clearly by the transverse acceleration figures which increase to forward and aft in the ship and thereby show the influence of transverse components of simultaneous vertical accelerations. Consequently there is no need to consider vertical accelerations separately in the transverse balances of forces and moments. These simultaneously acting vertical accelerations create an apparent increase of weight of the unit and thus improve the friction in the balance of forces, respectively the moment of stability in the balance of moments. For this reason there is no reduction of the normal force $m \cdot g$ due to the present angle of heel.

The situation is different for the longitudinal sliding balance. The worst case would be a peak value of the longitudinal force F_x accompanied by an extreme reduction of weight through the vertical force F_z .
4. The friction coefficients shown in the methods are somewhat reduced against appropriate figures in other publications. The reason for this should be seen in various influences which may appear in practical shipping as: moisture, grease, oil, dust and other residues, vibration of the ship.

There are certain stowage materials available which are said to increase friction considerably. Extended experience with these materials may bring additional coefficients into practical use.
5. The principal way of calculating forces within the securing elements of a complex securing arrangement should necessarily include the consideration of
 - load-elongation behaviour (elasticity),
 - geometrical arrangement (angles, length),
 - pretensionof each individual securing element.

This approach would require a large volume of information and a complex, iterative calculation. Still the results would be doubtful due to uncertain parameters.
Therefore the simplified approach was chosen with the assumption that the elements take an even load of CS (calculation strength) which is reduced against the MSL (maximum securing load) by the safety factor 1.5.
6. When employing the advanced calculation method the way of collecting data should be followed as shown in the calculated example. It is acceptable to estimate securing angles, to take average angles for a set of lashings and similarly arrive at reasonable figures of the levers a, b and c for the balance of moments.

It should be born in mind that meeting or missing the balance calculation just by a tiny change of one or the other parameter indicates to be near the goal anyway. There is no clear-cut border line between safety and non-safety. In doubt, the arrangement should be improved.

INTERNATIONAL MARITIME ORGANIZATION

4 ALBERT EMBANKMENT
LONDON SE1 7SR

Telephone: 0171-735 7611

Telegrams: INTERMAR-LONDON SE1

Telex: 23588

Telefax: 0171-587 3210



MSC/Circ.691

1 June 1995

Ref. T3/2.04

CONTAINERS AND CARGOES

CODE OF SAFE PRACTICE FOR CARGO STOWAGE AND SECURING (CSS CODE)

Amendments to the CSS Code

1 The Maritime Safety Committee, at its sixty-fifth session (9 to 17 May 1995), adopted, in accordance with operative paragraph 3 of Assembly resolution A.714(17) - Code of Safe Practice for Cargo Stowage and Securing (CSS Code) - the annexed amendments to the Code.

2 Member Governments are invited to bring the said amendments to the attention of shipowners, shipmasters and crews and all others concerned.

MSC/Circ.691

ANNEX

AMENDMENTS TO THE CODE OF SAFE PRACTICE FOR CARGO STOWAGE AND SECURING (CSS CODE)

Chapter 1

Replace the existing paragraph 1.6.2 by the following paragraph:

"1.6.2 The cargo securing arrangements detailed in the ship's Cargo Securing Manual, if provided, should be based on the forces expected to affect the cargo carried by the ship, calculated in accordance with the method described in Annex 13 or with a method accepted by the Administration or approved by a classification society acceptable to the Administration."

Annex 5

Add the following new paragraph 4 and renumber the existing paragraphs 4 to 9 accordingly:

"4 CARGO STOWED IN OPEN CONTAINERS, ON PLATFORMS OR PLATFORM-BASED CONTAINERS

4.1 While the stowage and securing of open containers, ISO platform or platform-based containers (flatracks) on a container ship or a ship fitted or adapted for the carriage of containers, should follow the information for that system, the stowage and securing of the cargo in such containers, should be carried out in accordance with the *IMO/ILO Guidelines for Packing Cargo in Freight Containers or Vehicles*.

4.2 When heavy cargo items are carried on ISO platform or platform-based containers (flatracks) the provisions of this Annex should be followed. Additionally, the following items should be taken into account:

- 1 The ISO standard platform, etc., used should be of a suitable type with regard to strength and MSL of the securing points.
- 2 The weight of the heavy cargo item should be properly distributed.
- 3 Where deemed necessary the heavy cargo item(s) carried on ISO standard platform or platform-based containers, etc., should not only be secured to the platform(s) or platform-based containers, etc., but also to neighbouring platforms(s), etc., or to securing points located at fixed structure of the ship. The elasticity of the last mentioned lashings should be sufficiently in line with the overall elasticity of the stowage block underneath the heavy cargo item(s) in order to avoid overloading those lashings."

Replace the existing paragraph 10 by the following new paragraph 11:

"11 SECURING CALCULATION

11.1 Where necessary, the securing arrangements for heavy cargo items should be verified by an appropriate calculation in accordance with Annex 13 to the Code."

ORGANISATION MARITIME INTERNATIONALE

4 ALBERT EMBANKMENT
LONDRES SE1 7SR

Téléphone : 0171-735 7611
Téléfax : 0171-587 3210
Télex : 23588 IMOLDN G



MSC/Circ.740
14 June 1996

Ref. T3/2.04

**AMENDMENT TO THE CODE OF SAFE PRACTICE FOR CARGO STOWAGE
AND SECURING (CSS CODE)**

1 The Maritime Safety Committee, at its sixty-sixth session (28 May to 6 June 1996) , approved the annexed amendment to the Code of Safe Practice for Cargo Stowage and Securing (CSS Code).

2 Member Governments are invited to bring the amendment to the attention of shipowners, ship operators, shipmasters and crews and all others concerned.

ANNEX

**AMENDMENT TO THE CODE OF SAFE PRACTICE
FOR CARGO STOWAGE AND SECURING (CSS CODE)**

Annex 12 - Safe stowage and securing of unit loads

In section 2 "Cargo information", in subparagraph .3, the word "and" is deleted, in subparagraph .4, "." is replaced by the word "; and ", and the following new subparagraph .5 is added:

".5 relevant examination certificates for pre-slung slings around cargo units. The slings should be identified by specific means, e.g. colour coding, batch numbers or otherwise."

INTERNATIONAL MARITIME ORGANIZATION

4 ALBERT EMBANKMENT
LONDON SE1 7SR

Telephone: 0171-735 7611
Fax: 0171-587 3210
Telex: 23588 IMOLDN G



MSC/Circ.812
16 June 1997

Ref. T3/2.01

**AMENDMENTS TO THE GUIDELINES FOR SECURING ARRANGEMENTS FOR THE
TRANSPORT OF ROAD VEHICLES ON RO-RO SHIPS (RESOLUTION A.581(14))
AND THE CODE OF SAFE PRACTICE FOR CARGO STOWAGE
AND SECURING (RESOLUTION A.714(17))**

1 The Maritime Safety Committee, at its sixty-eighth session (28 May to 6 June 1997), having considered draft amendments to the Guidelines for securing arrangements for the transport of road vehicles on ro-ro ships (resolution A.581(14)) and the Code of Safe Practice for Cargo Stowage and Securing (resolution A.714(17)), prepared by the Sub-Committee on Dangerous Goods, Solid Cargoes and Containers, at its second session, approved the proposed amendments set out in the annex.

2 These amendments aim at extending the provisions of the Guidelines for securing arrangements for transport of road vehicles on ro-ro ships, to cover the use of web lashings which are widely accepted on such ships.

3 Member Governments are invited to bring the attached amendments to the attention of all parties concerned with a view to implementing them as soon as possible.

ANNEX

**AMENDMENTS TO THE GUIDELINES FOR SECURING ARRANGEMENTS FOR THE
TRANSPORT OF ROAD VEHICLES ON RO-RO SHIPS (RESOLUTION A.581(14))
AND TO THE CODE OF SAFE PRACTICE FOR CARGO STOWAGE
AND SECURING (RESOLUTION A.714(17))**

**GUIDELINES FOR SECURING ARRANGEMENTS FOR THE TRANSPORT
OF ROAD VEHICLES ON RO-RO SHIPS (RESOLUTION A.581(14))**

- 1 The existing text of paragraph 4.2.3 is replaced by the following:

"The maximum securing load (MSL) of each securing point should be not less than 100 kN. If the securing point is designed to accommodate more than one lashing (y lashings), the MSL should be not less than $y \times 100$ kN".

- 2 The existing text of paragraph 6.1 is replaced by the following:

"The maximum securing load (MSL) of lashings should not be less than 100 kN, and they should be made of material having suitable elongation characteristics."

**CODE OF SAFE PRACTICE FOR CARGO STOWAGE AND SECURING
(RESOLUTION A.714(17))**

Annex 13 - Methods to assess the efficiency of securing arrangements for non-standardized cargo

- 3 In table 1 - "Determination of MSL from breaking strength", in the column "Material", the words "web lashing" are inserted below the words "fibre rope" and in the column "MSL", the expression "70% of breaking strength" is inserted below the expression "33% of breaking strength".

INTERNATIONAL MARITIME ORGANIZATION
4 ALBERT EMBANKMENT
LONDON SE1 7SR

Telephone: 020 7735 7611
Fax: 020 7587 3210
Telex: 23588 IMOLDN G



IMO

E

Ref. T3/1.01

MSC/Circ.1026
27 May 2002

**AMENDMENTS TO THE CODE OF SAFE PRACTICE FOR CARGO STOWAGE
AND SECURING (CSS CODE)**

- 1 The Maritime Safety Committee, at its seventy-fifth session (15 to 24 May 2002), approved the annexed amendments to the Code of Safe Practice for Cargo Stowage and Securing (CSS Code).
- 2 Member Governments are invited to bring the amendment to the attention of shipowners, ship operators, shipmasters and crews and all others concerned.

ANNEX

AMENDMENTS TO THE CODE OF SAFE PRACTICE FOR CARGO STOWAGE AND SECURING (CSS CODE)

ANNEX 13

Methods to assess the efficiency of securing arrangements for non-standardized cargo

1 SCOPE OF APPLICATION

1 In paragraph 1, after the second sentence a new sentence is added as follows:

“All lashing assemblies used in the application of the methods described in this annex must be attached to fixed securing points or strong supporting structures marked on the cargo unit or advised as being suitable, or taken as a loop around the unit with both ends secured to the same side as shown in Annex 5, Figure 2 of the Code. Lashings going over the top of the cargo unit, which have no defined securing direction but only act to increase friction by their pre-tension, cannot be credited in the evaluation of securing arrangements under this annex.”

4 STRENGTH OF SECURING EQUIPMENT

2 In paragraph 4.2, the second sentence in the first sub-paragraph is replaced by the following text:

“Safe Working Load (SWL) may be substituted for MSL for securing purposes, provided this is equal to or exceeds the strength defined by MSL.”

3 In Table 1 (as amended by MSC/Circ. 812), "70% of breaking strength" on the line regarding web lashing is replaced by "50% of breaking strength".

5 SAFETY FACTOR

4 Existing paragraph 5 is replaced by the following text and re-numbered as paragraph 6:

“When using balance calculation methods for assessing the strength of the securing devices, a safety factor is used to take account of the possibility of uneven distribution of forces among the devices or reduced capability due to the improper assembly of the devices or other reasons. This safety factor is used in the formula to derive the calculated strength (CS) from the MSL and shown in the relevant method used.

$$CS = MSL/safety\ factor$$

Notwithstanding the introduction of such a safety factor, care should be taken to use securing elements of similar material and length in order to provide a uniform elastic behaviour within the arrangement.”

MSC/Circ.1026

ANNEX

Page 2

6 RULE-OF-THUMB METHOD

5 Existing paragraph 6 is re-numbered as paragraph 5. Existing sub-paragraphs 6.1, 6.2 and 6.3 are re-numbered as 5.1, 5.2 and 5.3 accordingly.

7 ADVANCED CALCULATION METHOD

6 After Table 3 the following text and formula are added:

“For length/speed combinations not directly tabulated, the following formula may be used to obtain the correction factor with v = speed in knots and L = length between perpendiculars in metres:

$$\text{correction factor} = (0.345 \cdot v / \sqrt{L}) + (58.62 \cdot L - 1034.5) / L^2$$

This formula shall not be used for ship lengths less than 50 m or more than 300 m.”

7 Under the existing paragraph 7.2, the following text and a new table are added:

“Friction contributes towards prevention of sliding. The following friction coefficients (μ) should be applied.

Table 5 – Friction coefficients

Materials in contact	Friction coefficient, (μ)
timber-timber, wet or dry	0.4
steel-timber or steel-rubber	0.3
steel-steel, dry	0.1
steel-steel, wet	0.0

8 In paragraph 7.2.1, the text from (μ = 0.3 for steel-timber or steel-rubber) to (μ = 0.0 for steel-steel, wet) is deleted; “table 5” in the definition of f is replaced by “table 6”; and a formula is added under the definition of CS as follows:

$$CS = \frac{MSL}{1.5}$$

9 Existing Table 5 is re-numbered as Table 6.

10 Under the re-numbered Table 6, the following text is added:

“As an alternative to using Table 6 to determine the forces in a securing arrangement, the method outlined in paragraph 7.3 can be used to take account of transverse and longitudinal components of lashing forces.”

11 In paragraph 7.2.3, under the definition of CS a formula is added:

$$“CS = \frac{MSL}{1.5}”$$

- 12 A new paragraph 7.2.4 is added as follows:

“7.2.4 Calculated example

A calculated example for this method is shown in Appendix 1.”

- 13 A new paragraph 7.3 is added as follows:

“7.3 Balance of forces – alternative method

The balance of forces described in paragraph 7.2.1 and 7.2.3 will normally furnish a sufficiently accurate determination of the adequacy of the securing arrangement. However, this alternative method allows a more precise consideration of horizontal securing angles.

Securing devices usually do not have a pure longitudinal or transverse direction in practice but have an angle β in the horizontal plane. This horizontal securing angle β is defined in this annex as the angle of deviation from the transverse direction. The angle β is to be scaled in the quadrantal mode, i.e. between 0 and 90°.

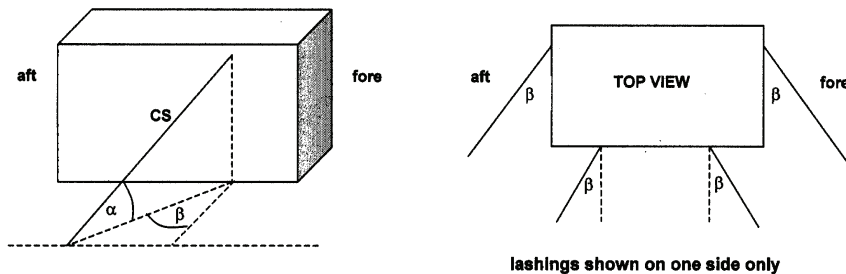

Figure 3 – Definition of the vertical and horizontal securing angles α and β

A securing device with an angle β develops securing effects both in longitudinal and transverse direction, which can be expressed by multiplying the calculated strength CS with the appropriate values of f_x or f_y . The values of f_x and f_y can be obtained from Table 7.

Table 7 consists of five sets of figures, one each for the friction coefficients $\mu = 0.4, 0.3, 0.2, 0.1$ and 0. Each set of figures is obtained by using the vertical angle α and horizontal angle β . The value of f_x is obtained when entering the table with β from the right while f_y is obtained when entering with β from the left, using the nearest tabular value for α and β . Interpolation is not required but may be used.

The balance calculations are made in accordance with the following formulae:

$$\begin{aligned} \text{Transverse sliding} &: F_y \leq \mu \cdot m \cdot g + f_{y1} \cdot CS_1 + \dots + f_{yn} \cdot CS_n \\ \text{Longitudinal sliding} &: F_x \leq \mu(m \cdot g - F_z) + f_{x1} \cdot CS_1 + \dots + f_{xn} \cdot CS_n \\ \text{Transverse tipping} &: F_y \cdot a \leq b \cdot m \cdot g + 0.9(CS_1 \cdot c_1 + CS_2 \cdot c_2 + \dots + CS_n \cdot c_n) \end{aligned}$$

Caution:

Securing devices, which have a vertical angle α of less than 45° in combination with horizontal angle β greater than 45° , should not be used in the balance of transverse tipping in the above formula.

All symbols used in these formulae have the same meaning as defined in paragraph 7.2 except f_y and f_x , obtained from Table 7, and CS is as follows:

$$CS = \frac{MSL}{1.35}$$

A calculated example for this method is shown in Appendix 1.

Table 7 – f_x -values and f_y -values as a function of α , β and μ

Table 7.1 for $\mu = 0.4$

β for f_y	α														β for f_x
	-30	-20	-10	0	10	20	30	40	45	50	60	70	80	90	
0	0.67	0.80	0.92	1.00	1.05	1.08	1.07	1.02	0.99	0.95	0.85	0.72	0.57	0.40	90
10	0.65	0.79	0.90	0.98	1.04	1.06	1.05	1.01	0.98	0.94	0.84	0.71	0.56	0.40	80
20	0.61	0.75	0.86	0.94	0.99	1.02	1.01	0.98	0.95	0.91	0.82	0.70	0.56	0.40	70
30	0.55	0.68	0.78	0.87	0.92	0.95	0.95	0.92	0.90	0.86	0.78	0.67	0.54	0.40	60
40	0.46	0.58	0.68	0.77	0.82	0.86	0.86	0.84	0.82	0.80	0.73	0.64	0.53	0.40	50
50	0.36	0.47	0.56	0.64	0.70	0.74	0.76	0.75	0.74	0.72	0.67	0.60	0.51	0.40	40
60	0.23	0.33	0.42	0.50	0.56	0.61	0.63	0.64	0.64	0.63	0.60	0.55	0.48	0.40	30
70	0.10	0.18	0.27	0.34	0.41	0.46	0.50	0.52	0.52	0.53	0.52	0.49	0.45	0.40	20
80	-0.05	0.03	0.10	0.17	0.24	0.30	0.35	0.39	0.41	0.42	0.43	0.44	0.42	0.40	10
90	-0.20	-0.14	-0.07	0.00	0.07	0.14	0.20	0.26	0.28	0.31	0.35	0.38	0.39	0.40	0

Table 7.2 for $\mu = 0.3$

β for f_y	α														β for f_x
	-30	-20	-10	0	10	20	30	40	45	50	60	70	80	90	
0	0.72	0.84	0.93	1.00	1.04	1.04	1.02	0.96	0.92	0.87	0.76	0.62	0.47	0.30	90
10	0.70	0.82	0.92	0.98	1.02	1.03	1.00	0.95	0.91	0.86	0.75	0.62	0.47	0.30	80
20	0.66	0.78	0.87	0.94	0.98	0.99	0.96	0.91	0.88	0.83	0.73	0.60	0.46	0.30	70
30	0.60	0.71	0.80	0.87	0.90	0.92	0.90	0.86	0.82	0.79	0.69	0.58	0.45	0.30	60
40	0.51	0.62	0.70	0.77	0.81	0.82	0.81	0.78	0.75	0.72	0.64	0.54	0.43	0.30	50
50	0.41	0.50	0.58	0.64	0.69	0.71	0.71	0.69	0.67	0.64	0.58	0.50	0.41	0.30	40
60	0.28	0.37	0.44	0.50	0.54	0.57	0.58	0.58	0.57	0.55	0.51	0.45	0.38	0.30	30
70	0.15	0.22	0.28	0.34	0.39	0.42	0.45	0.45	0.45	0.45	0.43	0.40	0.35	0.30	20
80	0.00	0.06	0.12	0.17	0.22	0.27	0.30	0.33	0.33	0.34	0.35	0.34	0.33	0.30	10
90	-0.15	-0.10	-0.05	0.00	0.05	0.10	0.15	0.19	0.21	0.23	0.26	0.28	0.30	0.30	0

Table 7.3 for $\mu = 0.2$

β for f_y	α														β for f_x
	-30	-20	-10	0	10	20	30	40	45	50	60	70	80	90	
0	0.77	0.87	0.95	1.00	1.02	1.01	0.97	0.89	0.85	0.80	0.67	0.53	0.37	0.20	90
10	0.75	0.86	0.94	0.98	1.00	0.99	0.95	0.88	0.84	0.79	0.67	0.52	0.37	0.20	80
20	0.71	0.81	0.89	0.94	0.96	0.95	0.91	0.85	0.81	0.76	0.64	0.51	0.36	0.20	70
30	0.65	0.75	0.82	0.87	0.89	0.88	0.85	0.79	0.75	0.71	0.61	0.48	0.35	0.20	60
40	0.56	0.65	0.72	0.77	0.79	0.79	0.76	0.72	0.68	0.65	0.56	0.45	0.33	0.20	50
50	0.46	0.54	0.60	0.64	0.67	0.67	0.66	0.62	0.60	0.57	0.49	0.41	0.31	0.20	40
60	0.33	0.40	0.46	0.50	0.53	0.54	0.53	0.51	0.49	0.47	0.42	0.36	0.28	0.20	30
70	0.20	0.25	0.30	0.34	0.37	0.39	0.40	0.39	0.38	0.37	0.34	0.30	0.26	0.20	20
80	0.05	0.09	0.14	0.17	0.21	0.23	0.25	0.26	0.26	0.26	0.26	0.25	0.23	0.20	10
90	-0.10	-0.07	-0.03	0.00	0.03	0.07	0.10	0.13	0.14	0.15	0.17	0.19	0.20	0.20	0

Table 7.4 for $\mu = 0.1$

β for f_y	α														β for f_x
	-30	-20	-10	0	10	20	30	40	45	50	60	70	80	90	
0	0.82	0.91	0.97	1.00	1.00	0.97	0.92	0.83	0.78	0.72	0.59	0.44	0.27	0.10	90
10	0.80	0.89	0.95	0.98	0.99	0.96	0.90	0.82	0.77	0.71	0.58	0.43	0.27	0.10	80
20	0.76	0.85	0.91	0.94	0.94	0.92	0.86	0.78	0.74	0.68	0.56	0.42	0.26	0.10	70
30	0.70	0.78	0.84	0.87	0.87	0.85	0.80	0.73	0.68	0.63	0.52	0.39	0.25	0.10	60
40	0.61	0.69	0.74	0.77	0.77	0.75	0.71	0.65	0.61	0.57	0.47	0.36	0.23	0.10	50
50	0.51	0.57	0.62	0.64	0.65	0.64	0.61	0.56	0.53	0.49	0.41	0.31	0.21	0.10	40
60	0.38	0.44	0.48	0.50	0.51	0.50	0.48	0.45	0.42	0.40	0.34	0.26	0.19	0.10	30
70	0.25	0.29	0.32	0.34	0.35	0.36	0.35	0.33	0.31	0.30	0.26	0.21	0.16	0.10	20
80	0.10	0.13	0.15	0.17	0.19	0.20	0.20	0.20	0.19	0.19	0.17	0.15	0.13	0.10	10
90	-0.05	-0.03	-0.02	0.00	0.02	0.03	0.05	0.06	0.07	0.08	0.09	0.09	0.10	0.10	0

Table 7.5 for $\mu = 0.0$

β for f_y	α														β for f_x
	-30	-20	-10	0	10	20	30	40	45	50	60	70	80	90	
0	0.87	0.94	0.98	1.00	0.98	0.94	0.87	0.77	0.71	0.64	0.50	0.34	0.17	0.00	90
10	0.85	0.93	0.97	0.98	0.97	0.93	0.85	0.75	0.70	0.63	0.49	0.34	0.17	0.00	80
20	0.81	0.88	0.93	0.94	0.93	0.88	0.81	0.72	0.66	0.60	0.47	0.32	0.16	0.00	70
30	0.75	0.81	0.85	0.87	0.85	0.81	0.75	0.66	0.61	0.56	0.43	0.30	0.15	0.00	60
40	0.66	0.72	0.75	0.77	0.75	0.72	0.66	0.59	0.54	0.49	0.38	0.26	0.13	0.00	50
50	0.56	0.60	0.63	0.64	0.63	0.60	0.56	0.49	0.45	0.41	0.32	0.22	0.11	0.00	40
60	0.43	0.47	0.49	0.50	0.49	0.47	0.43	0.38	0.35	0.32	0.25	0.17	0.09	0.00	30
70	0.30	0.32	0.34	0.34	0.34	0.32	0.30	0.26	0.24	0.22	0.17	0.12	0.06	0.00	20
80	0.15	0.16	0.17	0.17	0.17	0.16	0.15	0.13	0.12	0.11	0.09	0.06	0.03	0.00	10
90	0.00	0.00	0.00	0.00	0.00	0.00	0.00	0.00	0.00	0.00	0.00	0.00	0.00	0.00	0

Remark: $f_x = \cos \alpha \cdot \sin \beta + \mu \cdot \sin \alpha$ $f_y = \cos \alpha \cdot \cos \beta + \mu \cdot \sin \alpha$

14 The existing text under the heading “Advanced calculation method: calculated example” with the heading are deleted from section 7 and added in as new Appendix 1 to the Annex with modifications as following paragraphs 15 and 16.

15 In new Appendix 1, the words “Advanced calculation method: calculated example” are replaced by the follows:

“Calculated example 1
(refer to paragraph 7.2, Balance of forces and moments)”

16 In new Appendix 1, calculated example 2 is added after calculated example 1 as follows:

“Calculated example 2
(refer to paragraph 7.3, Balance of forces – alternative method)

A cargo unit of 68 t mass is stowed on timber ($\mu = 0.3$) in the ‘tween deck at 0.7 L of a vessel. L = 160m, B = 24 m, v = 18 kn and GM = 1.5 m. Dimensions of the cargo unit are height = 2.4 m and width = 1.8 m. The external forces are: Fx = 112 kN, Fy = 312 kN, Fz = 346 kN.

The top view shows the overall securing arrangement with eight lashings.

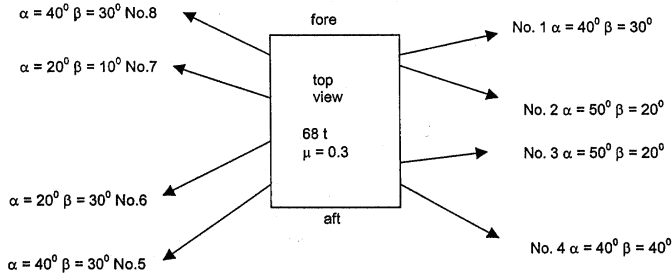

Calculation of balance of forces:

No.	MSL (KN)	CS (KN)	α	β	fy	Cs* fy	fx	Cs* fx
1	108	80	40° stbd	30° fwd	0.86	68.8 stbd	0.58	46.4 fwd
2	90	67	50° stbd	20° aft	0.83	55.6 stdb	0.45	30.2 aft
3	90	67	50° stbd	20° fwd	0.83	55.6 stdb	0.45	30.2 fwd
4	108	80	40° stbd	40° aft	0.78	62.4 stdb	0.69	55.2 aft
5	108	80	40° port	30° aft	0.86	68.8 port	0.58	46.4 aft
6	90	67	20° port	30° aft	0.99	66.3 port	0.57	38.2 aft
7	90	67	20° port	10° fwd	1.03	69.0 port	0.27	18.1 fwd
8	108	80	40° port	30° fwd	0.86	68.8 port	0.58	46.4 fwd

Transverse balance of forces (STBD arrangement) Nos. 1, 2, 3 and 4:

$$312 < 0.3 \cdot 68 \cdot 9.81 + 68.8 + 55.6 + 55.6 + 62.4$$

$$312 < 443 \quad \text{this is OK !}$$

Transverse balance of forces (PORT arrangement) Nos. 5, 6, 7 and 8:

$$312 < 0.3 \cdot 68 \cdot 9.81 + 68.8 + 66.3 + 69.0 + 68.8$$

$$312 < 473 \quad \text{this is OK!}$$

Longitudinal balance of forces (FWD arrangement) Nos. 1, 3, 7, 8:

$$112 < 0.3 (68 \cdot 9.81 - 346) + 46.4 + 30.2 + 18.1 + 46.4$$

$$112 < 237 \quad \text{this is OK !}$$

Longitude balance of forces (AFT arrangement) Nos. 2, 4, 5, 6:

$$112 < 0.3 (68 \cdot 9.81 - 346) + 30.2 + 55.2 + 46.4 + 38.2$$

$$112 < 266 \quad \text{this is OK!}$$

Transverse Tipping

Unless specific information is provided, the vertical center of gravity of the cargo unit can be assumed to be at one half the height and the transverse center of gravity at one half the width.
Also, if the lashing is connected as shown in the sketch, instead of measuring c, the length of the lever from the tipping axis to the lashing CS, it is conservative to assume that it is equal to the width of the cargo unit.

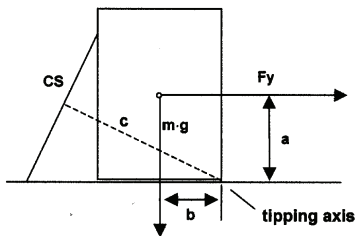

$$F_y \cdot a \leq b \cdot m \cdot g + 0.9 \cdot (CS_1 \cdot c_1 + CS_2 \cdot c_2 + CS_3 \cdot c_3 + CS_4 \cdot c_4)$$

$$312 \cdot 2.4/2 < 1.8/2 \cdot 68 \cdot 9.81 + 0.9 \cdot 1.8 \cdot (80 + 67 + 67 + 80)$$

$$374 < 600 + 476$$

$$374 < 1076 \quad \text{this is OK !}$$

17 The existing text under the heading “Explanation and interpretation of “Methods of assess the efficiency of securing arrangements for non-standardized cargo” with the heading are deleted from section 7 and added in as new Appendix 2 to the Annex.



4 ALBERT EMBANKMENT
LONDON SE1 7SR

Telephone: +44 (0)20 7735 7611

Fax: +44 (0)20 7587 3210

Ref. T3/1.02

MSC.1/Circ.1352

30 June 2010

**AMENDMENTS TO THE CODE OF SAFE PRACTICE FOR CARGO STOWAGE
AND SECURING (CSS CODE)**

1 The Maritime Safety Committee, at its eighty-seventh session (12 to 21 May 2010), approved amendments to the Code of Safe Practice for Cargo Stowage and Securing (CSS Code), set out in the annex.

2 Member Governments are invited to bring the annexed Amendments to the CSS Code to the attention of shipowners, ship operators, shipmasters and crews and all other parties concerned and, in particular, encourage shipowners and terminal operators to:

- .1 apply the annexed amendments in its entirety for containerships, the keels of which were laid or which are at a similar stage of construction on or after 1 January 2015;
- .2 apply sections 4.4 (Training and familiarization), 7.1 (Introduction), 7.3 (Maintenance) and section 8 (Specialized container safety design) to existing containerships, the keels of which were laid or which are at a similar stage of construction before 1 January 2015; and
- .3 apply the principles of this guidance contained in sections 6 (Design) and 7.2 (Operational procedures) to existing containerships as far as practical by the flag State Administration with the understanding that existing ships would not be required to be enlarged or undergo other major structural modifications as determined.

ANNEX

**AMENDMENTS TO THE CODE OF SAFE PRACTICE FOR
CARGO STOWAGE AND SECURING (CSS CODE)**

- 1 The following new annex 14 is inserted after the existing annex 13:

"ANNEX 14

**GUIDANCE ON PROVIDING SAFE WORKING CONDITIONS
FOR SECURING OF CONTAINERS ON DECK**

1 AIM

To ensure that persons engaged in carrying out container securing operations on deck have safe working conditions and, in particular safe access, appropriate securing equipment and safe places of work. These guidelines should be taken into account at the design stage when securing systems are devised. These guidelines provide shipowners, ship builders, classification societies, Administrations and ship designers with guidance on producing or authorizing a Cargo Safe Access Plan (CSAP).

2 SCOPE

Ships which are specifically designed and fitted for the purpose of carrying containers on deck.

3 DEFINITIONS

3.1 *Administration* means the Government of the State whose flag the ship is entitled to fly.

3.2 *Fencing* is a generic term for guardrails, safety rails, safety barriers and similar structures that provide protection against the falls of persons.

3.3 *Lashing positions* include positions:

- .1 in between container stows on hatch covers;
- .2 at the end of hatches;
- .3 on outboard lashing stanchions/pedestals;
- .4 outboard lashing positions on hatch covers; and
- .5 any other position where people work with container securing.

3.4 *SATLs* are semi-automatic twistlocks.

3.5 *Securing* includes lashing and unlashings.

3.6 *Stringers* are the uprights or sides of a ladder.

3.7 *Turnbuckles and lashing rods** include similar cargo securing devices.

* Refer to standard ISO 3874, Annex D Lashing rod systems and tensioning devices.

4 GENERAL

4.1 Introduction

4.1.1 Injuries to dockworkers on board visiting ships account for the majority of accidents that occur within container ports, with the most common activity that involves such injuries being the lashing/unlashing of deck containers. Ships' crew engaged in securing operations face similar dangers.

4.1.2 During the design and construction of containerships the provision of a safe place of work for lashing personnel is essential.

4.1.3 Container shipowners and designers are reminded of the dangers associated with container securing operations and urged to develop and use container securing systems which are safe by design. The aim should be to eliminate or at least minimize the need for:

- .1 container top work;
- .2 work in other equally hazardous locations; and
- .3 the use of heavy and difficult to handle securing equipment.

4.1.4 It should be borne in mind that providing safe working conditions for securing containers deals with matters relating to design, operation, and maintenance, and that the problems on large containerships are not the same as on smaller ones.

4.2 Revised Recommendations on safety of personnel during container securing operations (MSC.1/Circ.1263)

Shipowners, ship designers and Administrations should take into account the recommendations on safe design of securing arrangements contained in these guidelines, and in the Recommendations on safety of personnel during container securing operations (MSC.1/Circ.1263).

4.3 Cargo Safe Access Plan (CSAP)

4.3.1 The Guidelines for the preparation of the Cargo Securing Manual (MSC/Circ.745) requires ships which are specifically designed and fitted for the purpose of carrying containers to have an approved Cargo Safe Access Plan (CSAP) on board, for all areas where containers are secured.

4.3.2 Stakeholders, including, but not limited to shipowners, ship designers, ship builders, administrations, classification societies and lashing equipment manufacturers, should be involved at an early stage in the design of securing arrangements on containerships and in the development of the CSAP.

4.3.3 The CSAP should be developed at the design stage in accordance with chapter 5 of the annex to MSC.1/Circ.1353.

4.3.4 Designers should incorporate the recommendations of this annex into the CSAP so that safe working conditions can be maintained during all anticipated configurations of container stowage.

4.4 Training and familiarization

4.4.1 Personnel engaged in cargo securing operations should be trained in the lashing and unlashings of containers as necessary to carry out their duties in a safe manner. This should include the different types of lashing equipment that are expected to be used.

4.4.2 Personnel engaged in cargo securing operations should be trained in the identification and handling of bad order or defective securing gear in accordance with each ship's procedures to ensure damaged gear is segregated for repair and maintenance or disposal.

4.4.3 Personnel engaged in cargo securing operations should be trained to develop the knowledge and mental and physical manual handling skills that they require to do their job safely and efficiently, and to develop general safety awareness to recognize and avoid potential dangers.

4.4.4 Personnel should be trained in safe systems of work. Where personnel are involved in working at heights, they should be trained in the use of relevant equipment. Where practical, the use of fall protection equipment should take precedence over fall arrest systems.

4.4.5 Personnel who are required to handle thermal cables and/or connect and disconnect temperature control units should be given training in recognizing defective cables, receptacles and plugs.

4.4.6 Personnel engaged in containership cargo operations should be familiarized with the ship's unique characteristics and potential hazards arising from such operations necessary to carry out their duties.

5 RESPONSIBILITIES OF INVOLVED PARTIES

5.1 Administrations should ensure that:

- .1 lashing plans contained within the approved Cargo Securing Manual are compatible with the current design of the ship and the intended container securing method is both safe and physically possible;
- .2 the Cargo Securing Manual, lashing plans and the CSAP are kept up to date; and
- .3 lashing plans and the CSAP are compatible with the design of the vessel and the equipment available.

5.2 Shipowners and operators should ensure that:

- .1 portable cargo securing devices are certified and assigned with a maximum securing load (MSL). The MSL should be documented in the cargo securing manual as required by the CSS Code;
- .2 the operational recommendations of this annex are complied with;

- .3 correction, changes or amendments of the Cargo Securing Manual, lashing plans and the Cargo Safe Access Plan (CSAP) should be promptly sent to the competent authority for approval; and
 - .4 only compatible and certified equipment in safe condition is used.
- 5.3 Designers should follow design recommendations of these guidelines.
- 5.4 Shipbuilders should follow design recommendations of these guidelines.
- 5.5 Containership terminal operators should ensure that the recommendations of relevant parts of this annex are complied with.

6 DESIGN

6.1 General design considerations

6.1.1 Risk assessment

6.1.1.1 Risk assessments should be performed at the design stage taking into account the recommendations of this annex to ensure that securing operations can be safely carried out in all anticipated container configurations. This assessment should be conducted with a view toward developing the Cargo Safe Access Plan (CSAP). Hazards to be assessed should include but not be limited to:

- .1 slips, trips and falls;
- .2 falls from height;
- .3 injuries whilst manually handling lashing gear;
- .4 being struck by falling lashing gear or other objects;
- .5 potential damage due to container operations. High-risk areas should be identified in order to develop appropriate protection or other methods of preventing significant damage;
- .6 adjacent electrical risks (temperature controlled unit cable connections, etc.);
- .7 the adequacy of the access to all areas that is necessary to safely perform container securing operations;
- .8 ergonomics (e.g., size and weight of equipment) of handling lashing equipment; and
- .9 implications of lashing 9'6" high, or higher, containers and mixed stows of 40' and 45' containers.

6.1.1.2 Shipbuilders should collaborate with designers of securing equipment in conducting risk assessments and ensure that the following basic criteria are adhered to when building containerships.

6.1.2 Ship designers should ensure that container securing operations performed in outer positions can be accomplished safely. As a minimum, a platform should be provided on which to work safely. This platform should have fencing to prevent workers falling off it.

6.1.3 The space provided between the containers stows for workers to carry out lashing operations should provide:

- .1 a firm and level working surface;
- .2 a working area, excluding lashings in place, to provide a clear sight of twist lock handles and allow for the manipulation of lashing gear;
- .3 sufficient spaces to permit the lashing gear and other equipment to be stowed without causing a tripping hazard;
- .4 sufficient spaces between the fixing points of the lashing bars on deck, or on the hatch covers, to tighten the turnbuckles;
- .5 access in the form of ladders on hatch coamings;
- .6 safe access to lashing platforms;
- .7 protective fencing on lashing platforms; and
- .8 adequate lighting in line with these guidelines.

6.1.4 Ship designers should aim to eliminate the need to access and work on the tops of deck stows.

6.1.5 Platforms should be designed to provide a clear work area, unencumbered by deck piping and other obstructions and take into consideration:

- .1 containers must be capable of being stowed within safe reach of the workers using the platform; and
- .2 the work area size and the size of the securing components used.

6.2 Provisions for safe access

6.2.1 General provisions

6.2.1.1 The minimum clearance for transit areas should be at least 2 m high and 600 mm wide.

6.2.1.2 All relevant deck surfaces used for movement about the ship and all passageways and stairs should have non-slip surfaces.

6.2.1.3 Where necessary for safety, walkways on deck should be delineated by painted lines or otherwise marked by pictorial signs.

6.2.1.4 All protrusions in access ways, such as cleats, ribs and brackets that may give rise to a trip hazard should be highlighted in a contrasting colour.

6.2.2 Lashing position design (platforms, bridges and other lashing positions)

6.2.2.1 Lashing positions should be designed to eliminate the use of three high lashing bars and be positioned in close proximity to lashing equipment stowage areas. Lashing positions should be designed to provide a clear work area which is unencumbered by deck piping and other obstructions and take into consideration:

- .1 the need for containers to be stowed within safe reach of the personnel using the lashing position so that the horizontal operating distance from the securing point to the container does not exceed 1,100 mm and not less than 220 mm for lashing bridges and 130 mm for other positions;
- .2 the size of the working area and the movement of lashing personnel; and
- .3 the length and weight of lashing gear and securing components used.

6.2.2.2 The width of the lashing positions should preferably be 1,000 mm, but not less than 750 mm.

6.2.2.3 The width of permanent lashing bridges should be:

- .1 750 mm between top rails of fencing; and
- .2 a clear minimum of 600 mm between storage racks, lashing cleats and any other obstruction.

6.2.2.4 Platforms on the end of hatches and outboard lashing stations should preferably be at the same level as the top of the hatch covers.

6.2.2.5 Toe boards (or kick plates) should be provided around the sides of elevated lashing bridges and platforms to prevent securing equipment from falling and injuring people. Toe boards should preferably be 150 mm high, however, where this is not possible they should be at least 100 mm high.

6.2.2.6 Any openings in the lashing positions through which people can fall should be possible to be closed.

6.2.2.7 Lashing positions should not contain obstructions, such as storage bins or guides to reposition hatch covers.

6.2.2.8 Lashing positions which contain removable sections should be capable of being temporarily secured.

6.2.3 Fencing design

6.2.3.1 Bridges and platforms, where appropriate, should be fenced. As a minimum, fencing design should take into consideration:

- .1 the strength and height of the rails should be designed to prevent workers from falling;

- .2 flexibility in positioning the fencing of gaps. A horizontal unfenced gap should not be greater than 300 mm;
- .3 provisions for locking and removal of fencing as operational situations change based on stowage anticipated for that area;
- .4 damage to fencing and how to prevent failure due to that damage; and
- .5 adequate strength of any temporary fittings. These should be capable of being safely and securely installed.

6.2.3.2 The top rail of fencing should be 1 m high from the base, with two intermediate rails. The opening below the lowest course of the guard rails should not exceed 230 mm. The other courses should be not more than 380 mm apart.

6.2.3.3 Where possible fences and handrails should be highlighted with a contrasting colour to the background.

6.2.3.4 Athwartships cargo securing walkways should be protected by adequate fencing if an unguarded edge exists when the hatch cover is removed.

6.2.4 Ladder and manhole design

6.2.4.1 Where a fixed ladder gives access to the outside of a lashing position, the stringers should be connected at their extremities to the guardrails of the lashing position, irrespective of whether the ladder is sloping or vertical.

6.2.4.2 Where a fixed ladder gives access to a lashing position through an opening in the platform, the opening shall be protected with either a fixed grate with a lock back mechanism, which can be closed after access, or fencing. Grabrails should be provided to ensure safe access through the opening.

6.2.4.3 Where a fixed ladder gives access to a lashing position from the outside of the platform, the stringers of the ladder should be opened above the platform level to give a clear width of 700 to 750 mm to enable a person to pass through the stringers.

6.2.4.4 A fixed ladder should not slope at an angle greater than 25° from the vertical. Where the slope of a ladder exceeds 15° from the vertical, the ladder should be provided with suitable handrails not less than 540 mm apart, measured horizontally.

6.2.4.5 A fixed vertical ladder of a height exceeding 3 m, and any fixed vertical ladder, from which a person may fall into a hold, should be fitted with guard hoops, which should be constructed in accordance with paragraphs 6.2.4.6 and 6.2.4.7.

6.2.4.6 The ladder hoops should be uniformly spaced at intervals not exceeding 900 mm and should have a clearance of 750 mm from the rung to the back of the hoop and be connected by longitudinal strips secured to the inside of the hoops, each equally spaced round the circumference of the hoop.

6.2.4.7 The stringers should be carried above the floor level of the platform by at least 1 m and the ends of the stringers should be given lateral support and the top step or rung should be level with the floor of the platform unless the steps or rungs are fitted to the ends of the stringers.

6.2.4.8 As far as practicable, access ladders and walkways, and work platforms should be designed so that workers do not have to climb over piping or work in areas with permanent obstructions.

6.2.4.9 There should be no unprotected openings in any part of the workplace. Access opening must be protected with handrails or access covers that can be locked back during access.

6.2.4.10 As far as practicable, manholes should not be situated in transit areas, however, if they are, proper fencing should protect them.

6.2.4.11 Access ladders and manholes should be large enough for persons to safely enter and leave.

6.2.4.12 A foothold at least 150 mm deep should be provided.

6.2.4.13 Handholds should be provided at the top of the ladder to enable safe access to the platform to be gained.

6.2.4.14 Manhole openings that may present a fall hazard should be highlighted in contrasting colour around the rim of the opening.

6.2.4.15 Manhole openings at different levels of the lashing bridge should not be located directly below one another, as far as practicable.

6.3 Lashing systems

6.3.1 General provisions

Lashing systems, including tensioning devices, should:

- .1 conform to international standards^{*}, where applicable;
- .2 be compatible with the planned container stowages;
- .3 be compatible with the physical ability of persons to safely hold, deploy and use such equipment;
- .4 be uniform and compatible, e.g., twistlocks and lashing rod heads should not interfere with each other;
- .5 be subject to a periodic inspection and maintenance regime. Non-conforming items should be segregated for repair or disposal; and
- .6 be according to the CSM.

6.3.2 Twistlock design

6.3.2.1 Shipowners should ensure that the number of different types of twistlocks provided for cargo securing is kept to a minimum and clear instructions are provided for their operation. The use of too many different types of twistlocks may lead to confusion as to whether the twistlocks are locked.

* Refer to standard ISO 3874 – The Handling and Securing of Type 1 Freight Containers, annex A-D.

6.3.2.2 The design of twistlocks should ensure the following:

- .1 positive locking with easy up and down side identification;
- .2 dislodging from corner fitting is not possible even when grazing a surface;
- .3 access and visibility of the unlocking device is effective in operational situations;
- .4 unlocked positions are easily identifiable and do not relock inadvertently due to jolting or vibration; and
- .5 unlocking poles are as light as possible, of a simple design for ease of use.

6.3.2.3 Where it is not feasible to entirely eliminate working on the tops of container stows, the twistlock designs used should minimize the need for such working, e.g., use of SATLs, fully automatic twistlocks or similar design.

6.3.3 Lashing rod design

6.3.3.1 The design of containership securing systems should take into account the practical abilities of the workers to lift, reach, hold, control and connect the components called for in all situations anticipated in the cargo securing plan.

6.3.3.2 The maximum length of a lashing rod should be sufficient to reach the bottom corner fitting of a container on top of two high cube containers and be used in accordance with the instructions provided by the manufacturers.

6.3.3.3 The weight of lashing rods should be minimized as low as possible consistent with the necessary mechanical strength.

6.3.3.4 The head of the lashing rod that is inserted in the corner fitting should be designed with a pivot/hinge or other appropriate device so that the rod does not come out of the corner fitting accidentally.

6.3.3.5 The rod's length in conjunction with the length and design of the turnbuckle should be such that the need of extensions is eliminated when lashing high cube (9'6") containers.

6.3.3.6 Lightweight rods should be provided where special tools are needed to lash high cube containers.

6.3.4 Turnbuckle design

6.3.4.1 Turnbuckle end fittings should be designed to harmonize with the design of lashing rods.

6.3.4.2 Turnbuckles should be designed to minimize the work in operating them.

6.3.4.3 Anchor points for turnbuckles should be positioned to provide safe handling and to prevent the bending of rods.

6.3.4.4 To prevent hand injury during tightening or loosening motions, there should be a minimum distance of 70 mm between turnbuckles.

6.3.4.5 The turnbuckle should incorporate a locking mechanism which will ensure that the lashing does not work loose during the voyage.

6.3.4.6 The weight of turnbuckles should be minimized as low as possible consistent with the necessary mechanical strength.

6.3.5 Storage bins and lashing equipment stowage design

6.3.5.1 Bins or stowage places for lashing materials should be provided.

6.3.5.2 All lashing gear should be stowed as close to its intended place of use as possible.

6.3.5.3 The stowage of securing devices should be arranged so they can easily be retrieved from their stowage location.

6.3.5.4 Bins for faulty or damaged gear should also be provided and appropriately marked.

6.3.5.5 Bins should be of sufficient strength.

6.3.5.6 Bins and their carriers should be designed to be lifted off the vessel and restowed.

6.4 Lighting design

A lighting plan should be developed to provide for:

- .1 the proper illumination of access ways, not less than 10 lux (1 foot candle)^{*}, taking into account the shadows created by containers that may be stowed in the area to be lit, for example different length containers in or over the work area;
- .2 a separate fixed or temporary (where necessary) lighting system for each working space between the container bays, which is bright enough, not less than 50 lux (5 foot candle)^{*}, for the work to be done, but minimizes glare to the deck workers;
- .3 such illumination should, where possible, be designed as a permanent installation and adequately guarded against breakage; and
- .4 the illumination intensity should take into consideration the distance to the uppermost reaches where cargo securing equipment is utilized.

* Refer to Safety and Health in Ports, ILO Code of Practice, section 7.1.5.

7 OPERATIONAL AND MAINTENANCE PROCEDURES

7.1 Introduction

7.1.1 Procedures for safe lashing and securing operations should be included in the ship's Safety Management System as part of the ISM Code documentation.

7.1.2 Upon arrival of the ship, a safety assessment of the lashing positions and the access to those positions should be made before securing work commences.

7.2 Operational procedures

7.2.1 Container deck working

7.2.1.1 Transit areas should be safe and clear of cargo and all equipment.

7.2.1.2 Openings that are necessary for the operation of the ship, which are not protected by fencing, should be closed during cargo securing work. Any necessarily unprotected openings in work platforms (i.e. those with a potential fall of less than 2 m), and gaps and apertures on deck should be properly highlighted.

7.2.1.3 The use of fencing is essential to prevent falls. When openings in safety barriers are necessary to allow container crane movements, particularly with derricking cranes, removable fencing should be used whenever possible.

7.2.1.4 It should be taken into account that when lifting lashing bars that can weigh between 11 and 21 kg and turnbuckles between 16 and 23 kg, there may be a risk of injury and severe illness as a result of physical strain if handled above shoulder height with the arms extended. It is therefore recommended that personnel work in pairs to reduce the individual workload in securing the lashing gear.

7.2.1.5 The company involved with cargo operation should anticipate, identify, evaluate and control hazards and take appropriate measures to eliminate or minimize potential hazards to prevent in particular with harmful lumbar spinal damage and severe illness as a result of physical strain.

7.2.1.6 Personnel engaged in containership cargo operations should wear appropriate Personnel Protective Equipment (PPE) whilst carrying out lashing operations. The PPE should be provided by the company.

7.2.1.7 Manual twistlocks should only be used where safe access is provided.

7.2.1.8 Containers should not be stowed in spaces configured for larger sized containers unless they can be secured under safe working conditions.

7.2.2 Container top working

7.2.2.1 When work on container tops can not be avoided, safe means of access should be provided by the container cargo operation terminal, unless the ship has appropriate means of access in accordance with the CSAP.

7.2.2.2 Recommended practice involves the use of a safety cage lifted by a spreader to minimize the risk to personnel.

7.2.2.3 A safe method of work should be developed and implemented to ensure the safety of lashers when on the top of container stows on deck. Where practical, the use of fall prevention equipment should take precedence over fall arrest equipment.

7.2.3 Failure to provide safe lashing stations on board/carry out lashing by port workers

7.2.3.1 Where there are lashing and unlashings locations on board ship where no fall protection, such as adequate handrails are provided, and no other safe method can be found, the containers should not be lashed or unlashings and the situation should be reported to shoreside supervisor and the master or deck officer immediately.

7.2.3.2 If protective systems cannot be designed to provide safe protected access and lashing work positions, in all cargo configurations then cargo should not be stowed in that location. Neither crew nor shore workers should be subjected to hazardous working conditions in the normal course of securing cargo.

7.3 Maintenance

7.3.1 In line with section 2.3 (Inspection and maintenance schemes) of the Revised Guidelines for the preparation of the cargo securing manual (MSC.1/Circ.1353) all ships should maintain a record book, which should contain the procedures for accepting, maintaining and repairing or rejecting of cargo securing devices. The record book should also contain a record of inspections.

7.3.2 Lighting should be properly maintained.

7.3.3 Walkways, ladders, stairways and fencings should be subject to a periodic maintenance programme which will reduce/prevent corrosion and prevent subsequent collapse.

7.3.4 Corroded walkways, ladders, stairways and fencings should be repaired or replaced as soon as practicable. The repairs should be effected immediately if the corrosion could prevent safe operations.

7.3.5 It should be borne in mind that turnbuckles covered with grease are difficult to handle when tightening.

7.3.6 Storage bins and their carriers should be maintained in a safe condition.

8 SPECIALIZED CONTAINER SAFETY DESIGN

8.1 Temperature controlled unit power outlets should provide a safe, watertight electrical connection.

8.2 Temperature controlled unit power outlets should feature a heavy duty, interlocked and circuit breaker protected electrical power outlet. This should ensure the outlet can not be switched "live" until a plug is fully engaged and the actuator rod is pushed to the "On" position. Pulling the actuator rod to the "Off" position should manually de-energize the circuit.

8.3 The temperature controlled unit power circuit should de-energize automatically if the plug is accidentally withdrawn while in the "On" position. Also, the interlock mechanism should break the circuit while the pin and sleeve contacts are still engaged.

This provides total operator safety and protection against shock hazard while eliminating arcing damage to the plug and receptacle.

8.4 Temperature controlled unit power outlets should be designed to ensure that the worker is not standing directly in front of the socket when switching takes place.

8.5 The positioning of the temperature controlled unit feed outlets should not be such that the flexible cabling needs to be laid out in such a way as to cause a tripping hazard.

8.6 Stevedores or ship's crew who are required to handle temperature controlled unit cables and/or connect and disconnect reefer units should be given training in recognizing defective wires and plugs.

8.7 Means or provisions should be provided to lay the temperature controlled unit cables in and protect them from lashing equipment falling on them during lashing operations.

8.8 Defective or inoperative temperature controlled unit plugs/electrical banks should be identified and confirmed as "locked out/tagged out" by the vessel.

9 REFERENCES

ILO Code of Practice – Safety and Health in Ports

ILO Convention 152 – Occupational Safety and Health in Dock Work

ISO Standard 3874 – The Handling and Securing of Type 1 Freight Containers

International Convention on Load Lines, 1966, as modified by the 1988 LL Protocol

Revised Recommendation on safety of personnel during container securing operations (MSC.1/Circ.1263)

Revised Guidelines for the preparation of the Cargo Securing Manual (MSC.1/Circ.1353)."

(TSFS 2013:99)

ASSEMBLY
27th session
Agenda item 9

A 27/Res.1048
20 December 2011
Original: ENGLISH

Resolution A.1048(27)

**Adopted on 30 November 2011
(Agenda item 9)**

**CODE OF SAFE PRACTICE FOR SHIPS CARRYING TIMBER
DECK CARGOES, 2011 (2011 TDC CODE)**

THE ASSEMBLY,

RECALLING Article 15(j) of the Convention on the International Maritime Organization regarding the functions of the Assembly in relation to regulations and guidelines concerning maritime safety,

RECALLING ALSO its adoption, by resolution A.715(17), of the Code of Safe Practice for Ships Carrying Timber Deck Cargoes, 1991,

RECOGNIZING the need to improve the provisions contained in the Code in the light of experience gained,

HAVING CONSIDERED the recommendations made by the Maritime Safety Committee at its eighty-ninth session,

1. ADOPTS the Code of Safe Practice for Ships Carrying Timber Deck Cargoes, 2011 (2011 TDC Code), as set out in the annex to the present resolution;
2. RECOMMENDS Governments to use the provisions of the 2011 TDC Code as a basis for relevant safety standards;
3. AUTHORIZES the Maritime Safety Committee to amend the Code as necessary in the light of further studies and experience gained from the implementation of the provisions contained therein;
4. REVOKES resolution A.715(17).

Annex

**CODE OF SAFE PRACTICE FOR SHIPS CARRYING TIMBER
DECK CARGOES, 2011 (2011 TDC CODE)**

PREFACE	4
CHAPTER 1 – GENERAL	5
1.1 Purpose	5
1.2 Application	5
1.3 Definitions	5
PART A – OPERATIONAL REQUIREMENTS	8
CHAPTER 2 – GENERAL RECOMMENDATIONS ON STOWAGE AND SECURING OF TIMBER DECK CARGOES	8
2.1 Goals	8
2.2 Pre-loading operation	8
2.3 Permitted loading weights on decks and hatch covers	9
2.4 Stability	9
2.5 Load line	10
2.6 Timber freeboard	10
2.7 Visibility	10
2.8 Work safety and work environment aspects	10
2.9 Stowage	12
2.10 Securing	13
2.11 Post-loading operation	17
2.12 Voyage planning	17
2.13 Cargo Securing Manual	18
CHAPTER 3 – VISIBILITY	20
CHAPTER 4 – PHYSICAL PROPERTIES OF TIMBER CARGOES	21
4.1 Stowage factors	21
4.2 Friction factors	21
4.3 Plastic covers	22
4.4 Package marking	23
4.5 Water absorption	23
4.6 Weight of ice	23
4.7 Rigidity of sawn wood packages	23
PART B – DESIGN OF CARGO SECURING ARRANGEMENTS	24
CHAPTER 5: DESIGN PRINCIPLES	24
5.1 General	24
5.2 Uprights	25
5.3 Loose or packaged sawn wood	26
5.4 Logs, poles, cants or similar cargo	26
5.5 Testing, marking, examination and certification	27
5.6 Lashing plans	27

CHAPTER 6: ALTERNATIVE DESIGN PRINCIPLES	28
6.1 General requirements	28
6.2 Accelerations and forces acting on the cargo	28
6.3 Physical properties of timber deck cargoes	29
6.4 Safety factors	30
6.5 Design criteria for different securing arrangements	31
CHAPTER 7: UPRIGHTS	37
CHAPTER 8: DENOTATIONS USED	40
ANNEX A – GUIDANCE IN DEVELOPING PROCEDURES AND CHECKLISTS	41
A.1 Preparations before loading of timber deck cargoes	41
A.2 Safety during loading and securing of timber deck cargoes	43
A.3 Securing of timber deck cargoes	45
A.4 Actions to be taken during the voyage	46
A.5 Safety during discharge of timber deck cargoes	48
ANNEX B – SAMPLES OF STOWAGE AND SECURING ARRANGEMENTS	50
B.1 Example calculation – Top-over lashings	50
B.2 Example calculation – Bottom blocking and top-over lashings	52
B.3 Example calculation – Loop lashings	53
B.4 Example calculation – Uprights for packages of sawn wood	56
B.5 Example calculation – Uprights for round wood	58
B.6 Example calculation – Frictional securing of transversely stowed round wood	66
B.7 Maximum bending resistance in common profiles for uprights	67
ANNEX C – INSTRUCTION TO A MASTER ON CALCULATION OF MASS CHANGE OF A TIMBER DECK CARGO DUE TO WATER ABSORPTION	69
ANNEX D – REFERENCES	70

PREFACE

The Code of Safe Practice for Ships Carrying Timber Deck Cargoes was first developed by the Organization in 1972 and subsequently amended in 1978.

The Code was revised by IMO resolution A.715(17) – Code of Safe Practice for Ships Carrying Timber Deck Cargoes, 1991, which was adopted on 6 November 1991.

This Code is based on the previous Code, which has been revised and amended in order to reflect the capability of today's ships and the equipment available on board and also taking expected future innovations in mind.

This Code is designed to assist:

- .1 shipowners, charterers, operating companies and ships' crew;
- .2 port industries, shippers and pre-packaging organizations, which are involved in preparation, loading, and stowing of timber deck cargoes; and
- .3 Administrations, manufacturers and designers of ships and equipment associated with the carriage of timber deck cargoes and those developing cargo securing manuals,

in the carriage of timber deck cargoes.

This Code is directed primarily at providing recommendations for the safe carriage of timber deck cargoes.

Status of references

The references given in this consolidated text do not form part of the Code but are inserted for ease of reference.

CHAPTER 1 – GENERAL

1.1 Purpose

1.1.1 The purpose of the Code is to ensure that timber deck cargoes are loaded, stowed and secured to prevent, as far as practicable, throughout the voyage, damage or hazard to the ship and persons on board as well as loss of cargo overboard⁽¹⁾.

1.1.2 The Code provides:

- .1 practices for safe transportation;
- .2 methodologies for safe stowage and securing;
- .3 design principles for securing systems;
- .4 guidance for developing procedures and instructions to be included in ships' cargo securing manuals on safe stowage and securing; and
- .5 sample checklists for safe stowage and securing.

1.2 Application

1.2.1 The provisions of this Code apply to all ships of 24 metres or more in length, carrying a timber deck cargo. This Code will be effective from [to be decided].

1.2.2 Cargo securing of timber deck cargoes should be in accordance with the requirements in the ship's Cargo Securing Manual (CSM), based on the principles in chapter 5 or chapter 6 of Part B of this Code.

1.2.3 The Master should note that national requirements may exist which may restrict the application of either chapter 5 or chapter 6, and these may also require third party inspections to ensure that the cargo has been properly secured according to the ship's cargo securing manual.

1.2.4 Cargo securing manuals for timber deck cargoes, approved following the implementation date of this Code, should meet the contents of this Code. Existing cargo securing manuals approved under the previous Timber Deck Cargo Code (resolution A.715(17)) may remain valid.

1.3 Definitions

1.3.1 The following *definitions* apply to this Code:

General expressions

- .1 *Administration* means the Government of the State whose flag the ship is entitled to fly.
- .2 *Company* means the Owner of the ship or any other organization or person such as the Manager, or the Bareboat Charterer, who has assumed the responsibility for operation of the ship from the Ship owner and who, on assuming such responsibility, has agreed to take over all duties and responsibilities imposed by SOLAS⁽²⁾.

- .3 *Load Lines Convention* means the International Convention on Load Lines, 1966, or the 1988 Protocol relating thereto, as applicable.
- .4 *Organization* means the International Maritime Organization (IMO).
- .5 *Port industries* means the port facilities and/or stevedoring companies serving ships engaged in the stowage of timber deck cargoes.
- .6 *Shipper* means any person, organization or Government which prepares or provides a consignment for transport⁽³⁾.
- .7 *SOLAS* means the International Convention for the Safety of Life at Sea, 1974, as amended.
- .8 *2008 IS Code* means the International Code on Intact Stability, 2008.
- .9 *Restricted sea area* means any sea area in which the weather can be forecast for the entire sea voyage or shelter can be found during the voyage.

Cargo related expressions

- .10 *Cant* means a log which is "slab-cut", i.e. ripped lengthwise so that the resulting thick pieces have two opposing, parallel flat sides and, in some cases, a third side which is sawn flat.
- .11 *Non-rigid cargo* means sawn wood or lumber, cants, logs, poles, pulpwood and all other types of loose timber or timber in packaged forms not fulfilling specified strength requirement, as defined in section 4.7.
- .12 *Rigid cargo package* means sawn wood or lumber, cants, logs, poles, pulpwood and all other types of timber in packaged forms, fulfilling specified strength requirement, as defined in section 4.7.
- .13 *Round wood* means parts of trees that have not been sawn on more than one long side. The term includes, among others, logs, poles and pulpwood in loose or packed form.
- .14 *Sawn wood* means parts of trees that have been sawn so that they have at least two parallel flat long sides. The term includes, among others, lumber and cants in loose or packed form.
- .15 *Timber* is used as a collective expression used for all types of wooden material covered by this Code, including both round and sawn wood but excluding wood pulp and similar cargo.

Technically related expressions

- .16 *Blocking device* means physical measures to prevent sliding and/or tipping of cargoes and/or collapse of stow.
- .17 *Lashing plan* means a sketch or drawing showing the required number and strength of securing items for the timber deck cargo to obtain safe stowage and securing of timber deck cargoes.

- .18 *Timber deck cargo* means a cargo of timber carried on an uncovered part of a freeboard or superstructure deck.
- .19 *Timber load line* means a special load line assigned to ships complying with certain conditions set out in the International Convention on Load Lines.
- .20 *Stowage Factor (SF)* means the volume occupied by one tonne of a cargo when stowed and separated in the accepted manner.
- .21 *Weather deck* means the uppermost complete deck exposed to weather and sea.
- .22 *Reeving* means the process where a rope, chain or any other type of lashing can freely move through a sheave or over a fulcrum such as a rounded angle piece, in such a manner so as to minimize the frictional effect of such movement.
- .23 *Height of cargo* means the distance from the base of the deck cargo stow to the highest part of the cargo.

PART A – OPERATIONAL REQUIREMENTS**CHAPTER 2 – GENERAL RECOMMENDATIONS ON STOWAGE
AND SECURING OF TIMBER DECK CARGOES****2.1 Goals**

2.1.1 The stowage and cargo securing arrangements for timber deck cargoes should enable a safe yet rational securing of the cargo so that it is satisfactorily prevented from shifting by collapsing, sliding or tipping in any direction, taking into account the acceleration forces the cargo may be subjected to throughout the voyage in the worst sea and weather conditions which may be expected.

2.1.2 This chapter lists measures and factors that should be taken under consideration in order to achieve such level of cargo securing.

2.1.3 Procedures should be established for the preparation of plans and instructions, including checklists as appropriate, for key shipboard operations⁽⁵⁾. Guidance is provided in Annex A to assist the development of such checklists.

2.2 Pre-loading operation

2.2.1 Prior to loading the vessel, relevant cargo information,⁽⁴⁾ as defined in chapter 4 of this Code, should be provided by the shipper, according to the custom of the trade.

2.2.2 The master of the vessel should study the relevant cargo information and take the precautions necessary for proper stowage, securing and safe carriage of the cargo as defined in this Code and as prescribed in the vessel's Cargo Securing Manual.

2.2.3 Prior to loading, the stevedoring company should be made aware of specific requirements according to the ship's Cargo Securing Manual regarding stowage and securing of timber deck cargoes.

2.2.4 During loading of deck cargo the master should ensure that all tanks are maintained in such a condition that free surface effects are minimized. Ballast tanks should as far as practicable be either full or empty and ballast movement during loading operations should be avoided.

2.2.5 Before timber deck cargo is loaded on any area of the weather deck:

- .1 hatch covers and other openings to spaces below that area should be securely closed and battened down;
- .2 air pipes and ventilators should be effectively protected and check-valves or similar devices should be examined to ascertain their effectiveness against the entry of water;
- .3 objects which might obstruct cargo stowage on deck should be removed and safely secured in places appropriate for storage;
- .4 the condition of friction-enhancing arrangements, where fitted, should be checked;

- .5 accumulations of ice and snow on such area should be removed;
- .6 it is normally preferable to have all deck lashings, uprights, etc., readily available before loading on that specific area. This will be necessary should a preloading examination of securing equipment be required in the loading port; and
- .7 all sounding pipes on the deck should be reviewed and arrangements made that access to these remain as far as practicable.

2.2.6 Further aspects to be considered during pre-loading operations are given in Annex A, chapter A.1.

2.3 Permitted loading weights on decks and hatch covers

2.3.1 The hatch cover securing and support arrangements, chocks, etc., as well as coamings should be designed and reinforced as necessary for carriage of timber deck cargoes. Potential weight increase of timber deck cargoes due to water absorption, icing, etc., should be taken under consideration.

2.3.2 Care should be taken not to exceed the designed maximum permissible loads on weather deck and hatch covers during any stage of the voyage⁽⁶⁾.

2.4 Stability

2.4.1 The master should ensure that the ship condition complies with its stability booklet at all times.

2.4.2 A ship carrying timber deck cargo should continue to comply with applicable damage stability requirements (e.g. SOLAS regulation II-1/4.1 or Load Lines Convention, regulation 27, as appropriate) and, additionally, the 2008 IS Code⁽¹¹⁾, particularly the timber deck cargo requirements. Since excessive GM values induce large accelerations, GM should preferably not exceed 3% of the breadth of the vessel, as indicated in paragraph 3.7.5 of the 2008 IS Code.

2.4.3 Ballast water exchange operations should be carried out in accordance with instructions in the Ballast Water Management Plan, if available⁽¹²⁾. The ballast water exchange operation, if required, should be considered when planning the amount of cargo to be loaded on deck.

2.4.4 According to the 2008 IS Code⁽¹¹⁾, account may be taken of the buoyancy of timber deck cargo when calculating stability curves, assuming that such cargo has a permeability up to 25%. Permeability is defined as the percentage of empty space of the volume occupied by the deck cargo. Additional curves of stability may be required if the Administration considers it necessary to investigate the influence of different permeabilities and/or assumed effective height of the deck cargo. 25% permeability corresponds to sawn wood cargo and 40%-60% permeability corresponds to round wood cargo with increasing permeability with increasing log diameters.

2.5 Load line

2.5.1 Ships assigned and making use of their timber load line should follow relevant regulations of the applicable Load Lines Convention for stowage and securing of timber as prescribed in the ship's Cargo Securing Manual. Special attention should be paid to the requirements concerning the breadth of the stow and voids in the stow (Load Lines Convention, regulation 44). When timber load lines are utilized, the timber is to be stowed as close as possible to the ship's sides with any gaps not to exceed a mean of 4% of the breadth of the ship.⁽¹³⁾

2.5.2 It should be noted that not all the diagrams provided in this Code assume that timber load lines are being utilized, thus the cargo may not be shown as complying with Load Lines Convention, regulation 44.

2.6 Timber freeboard

2.6.1 The timber freeboard, if applicable, will be found in the ship's Load Line Certificate.

2.6.2 Instructions on computation of the timber freeboard are given in the applicable Load Lines Convention⁽¹⁴⁾.

2.7 Visibility

2.7.1 Timber deck cargo should be loaded in such a manner as to ensure that the ship complies with the visibility requirements contained in SOLAS chapter V. National deviations may exist and should be taken into consideration as required dependent on the intended voyage.

2.7.2 The SOLAS requirements on visibility as well as instructions on how to calculate the visibility range are given in chapter 3.

2.8 Work safety and work environment aspects

2.8.1 The Company should establish procedures by which the ship's personnel receive relevant information on the Safety Management System⁽¹⁶⁾ in a working language or languages understood by them.

2.8.2 When deck cargo is being lashed and secured, special measures may be needed to ensure safe access to the top of, and across, the cargo so that the risk of falling is minimized. Safety helmets, proper footwear and non-obstructive high visibility garments should be worn during work on deck.

2.8.3 The risk of slipping should especially be considered during winter time when loading timber packages covered by plastic wrapping or tarpaulins. Plastic wrapping on packages with lumber of uneven length should be avoided or otherwise clearly identified.

2.8.4 Lighting during loading and discharge operations should be reasonably constant and arranged to minimize glare and dazzle, the formation of deep shadows and sharp contrasts in the level of illumination between one area and another.

2.8.5 Any obstruction such as lashings or securing points in the access way of escape routes and spaces essential to operation of the vessel, such as machinery spaces and crew's quarters, as well as obstructions to safety equipment, fire-fighting equipment and sounding pipes, should be clearly marked. In no case should an obstruction prevent safe access or egress of escape arrangements and spaces referred to above.

2.8.6 During the course of the voyage, if there is no convenient passage for the crew on or below the deck of the ship⁽¹⁸⁾ giving safe means of access from the accommodation to all parts used in the necessary working of the ship, guard lines or rails, not more than 330 mm apart vertically, should be provided on each side of the deck cargo to a height of at least 1 m above the cargo. In addition, a lifeline, preferably wire rope, set up taut with a tightening device should be provided as near as practicable to the centreline of the ship. The stanchion supports to all guardrails or lifelines should be spaced so as to prevent undue sagging. Where the cargo is uneven, a safe walking surface of not less than 600 mm in width should be fitted over the cargo and effectively secured beneath, or adjacent to, the lifeline.

2.8.7 Fencing or means of closing should be provided for all openings in the stow such as at masts, winches, etc.

2.8.8 Where uprights are not fitted or where alternative to the provisions of 2.8.6 are permitted, a walkway of substantial construction should be provided having an even walking surface and consisting of two fore and aft sets of guardlines or rails about 1 m apart, each having a minimum of three courses of guardlines or rails to a height of not less than 1 m above the walking surface. Such guardlines or rails should be supported by rigid stanchions spaced not more than 3 m apart and lines should be set up taut by tightening devices.

2.8.9 As an alternative to 2.8.6, 2.8.7 and 2.8.8, a lifeline, preferably wire rope, may be erected above the timber deck cargo such that a crew member equipped with a fall protection system can hook on to it and work about the timber deck cargo. The lifeline should be:

- .1 erected about 2 m above the timber deck cargo as near as practicable to the centreline of the ship;
- .2 stretched sufficiently taut with a tightening device to support a fallen crew member without collapse or failure.

2.8.10 Properly constructed ladders, steps or ramps fitted with guard lines or handrails should be provided from the top of the cargo to the deck, and in other cases where the cargo is stepped, in order to provide reasonable access.

2.8.11 Personnel safety equipment referred to in this chapter should be kept in an easily accessible place.

2.8.12 When lashings need to be checked and/or retightened during voyage, the Master should take appropriate actions to reduce the motion of the vessel during such operation.

2.8.13 Additional guidance regarding work safety and work environment aspects can be found in the relevant International Labour Organization (ILO) Conventions⁽¹⁷⁾.

2.8.14 Noting the particular arrangements of a ship loaded with timber deck cargo, pilot boarding arrangements should be carefully considered (see also SOLAS regulation V/23).

2.9 Stowage

2.9.1 The basic principle for the safe carriage of timber deck cargo is to make the stow as solid, compact and stable as practicable. The purpose of this is to:

- .1 prevent movement in the stow which could cause the lashings to slacken;
- .2 produce a binding effect within the stow; and
- .3 reduce to a minimum the permeability of the stow.

2.9.2 Openings in the deck exposed to weather over which cargo is stowed should be securely closed and battened down. The ventilators and air pipes should be effectively protected⁽¹⁹⁾.

2.9.3 Deck cargo should be stowed so that access is provided to and from designated escape routes and spaces essential to operation of the vessel, such as machinery spaces and crew's quarters, as well as to safety equipment, fire-fighting equipment and sounding pipes⁽¹⁸⁾. It should not interfere in any way with the navigation and necessary work of the ship⁽¹⁹⁾.

2.9.4 When cargo is loaded voids may occur in the stow between packages as well as between bulwarks or gantry crane rails, etc., and other fixed constructions such as the hatch coaming.

2.9.5 Care should be taken to avoid the creation of voids or open spaces when loading cargo. Voids, where created, should be filled with loose timber or blocked by vertical H-frames with required strength to avoid cargo shifting. The MSL for double H-frames of different widths and dimensions are given in the table below. The values apply to H-frames made of sound softwood timber without knots.

Table 2.1. MSL (maximum secure load) of H-frames for different dimensions

Dimensions of battens mm	MSL in kN of double H-frames with different widths			
	0.5 m	1.0 m	1.5 m	2.0 m
50 x 50	75	53	30	17
50 x 75	113	79	46	26
50 x 100	151	106	61	34
50 x 150	226	159	91	51
75 x 75	186	153	119	85
75 x 100	248	203	159	114
75 x 150		305	238	171
75 x 200			317	227
100 x 100		301	256	212

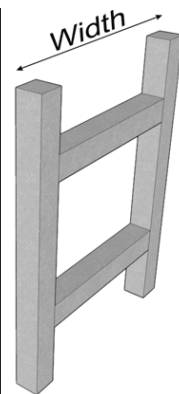

2.9.6 Timber deck cargo which substantially overhangs (one-third of the package length) hatch coamings or other structures in the longitudinal direction, should be supported at the outer end by other cargo stowed on deck or railing or equivalent structure of sufficient strength to support it.

2.9.7 For ships assigned and making use of a timber load line, additional practices apply in accordance with the applicable Load Lines Convention⁽¹⁹⁾.

2.10 Securing

2.10.1 One or more of the following principal methods may be used to secure timber deck cargoes, by themselves or in combination with each other:

- .1 different types of lashing arrangements;
- .2 bottom blocking of the base tier in combination with lashing arrangements;
- .3 blocking over the full height of the cargo by, e.g. uprights alternatively complemented by lashing arrangements;
- .4 frictional securing, taking into account scientific research and appropriate weather and voyage criteria; and
- .5 other practical securing enhancement, (taking into account appropriate weather and voyage criteria), such as:
 - .1 non slip paints on hatch covers;
 - .2 liberal use of dunnage in the stow to shore and bridge gaps;
 - .3 double lashing in exposed areas; and
 - .4 consideration given to the use of locking tiers.

2.10.2 Securing arrangements used should be designed in accordance with Part B and documented in accordance with section 2.13 of this Code.

Lashings

2.10.3 Different lashing arrangements are described in Part B of this Code.

2.10.4 The following three types of lashing equipment with different strength and elongation characteristics are most frequently used for securing timber deck cargoes. Individual suitability should be determined by such factors as ship type, size and area of operation, and as described in this Code and as prescribed in the cargo securing manual:

- .1 chain lashings;
- .2 wire lashings; and
- .3 fabricated web lashings.

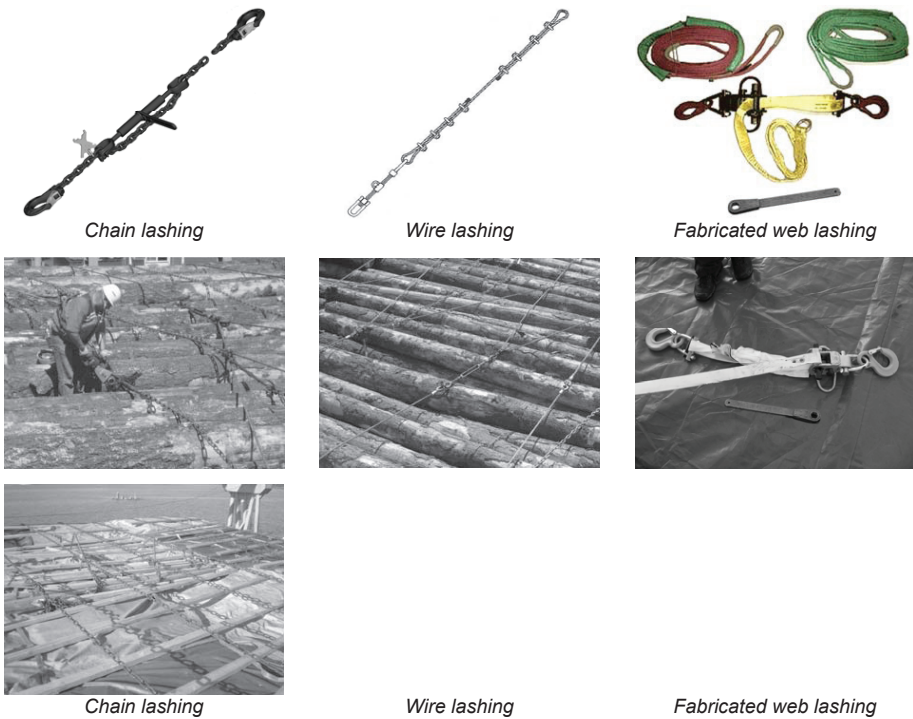

Figure 2.1 – Examples of different types of lashing equipment

Open hooks, which may loosen if the lashing becomes slack, should not be used in securing arrangements for timber deck cargoes. Web lashing should not be used in combination with chain or wire lashing.

2.10.5 The appropriate safety factors for the different types of equipment are described in Annex 13 to the Code of Safe Practice for Cargo Stowage and Securing (CSS Code).

2.10.6 All lashing equipment should be visually examined according to the instruction in the cargo securing manual before use and only equipment fit for purpose should be used for securing of timber deck cargoes.

2.10.7 The necessary pre-tension in the lashings used should be maintained throughout the voyage. It is of paramount importance that all lashings be carefully examined and tightened at the beginning of the voyage as the vibration and working of the ship will cause the cargo to settle and compact. They should be further examined at regular intervals during the voyage and tightened as necessary.

2.10.8 Entries of all examinations and adjustments to lashings should be made in the ship's logbook.

2.10.9 Slip hooks or other appropriate methods may be used for quick and safe adjustment of lashings. Pelican hooks, when used, should be moused.

2.10.10 Corner protectors should be used to prevent lashings from cutting into the cargo and to protect lashings from sharp corners. The latter especially applies to fabricated web lashings.

2.10.11 Every lashing should be provided with a tightening device or system so placed that it can safely and efficiently operate when required.

Uprights

2.10.12 Uprights should be fitted when required by this Code and as prescribed in the ship's cargo securing manual in accordance with the nature, height or character of the timber deck cargo. They should be designed in accordance with the criteria in chapter 7 of this Code and fitted in accordance with the ship's cargo securing manual. If there is an operational limit of the uprights (in terms of wave heights) this should be indicated in the ship's Cargo Securing Manual.

2.10.13 The uprights should be well fastened to the deck, hatches or coamings of the vessel (where adequate strength exists) and restrained from falling inwards during loading and discharging operations.

Lashing arrangements

2.10.14 In order to achieve a more secure stowage of logs when stowed on deck hog wires may be utilized. Such hog wire should be installed in the following manner:

- .1 At approximately three quarters of the height of the stow, the hog wire should be rove through a padeye attached to the uprights at this level so as to run transversely, connecting the respective port and starboard uprights. The hog lashing wire should not be too tight when laid so that it becomes taut when overstowed with other logs.
- .2 A second hog wire may be applied in a similar manner if the height of the hatch cover is less than 2 m. Such second hog wire should be installed approximately 1 m above the hatch covers.
- .3 The aim of having the hog wires applied in this manner is to assist in obtaining as even a tension as possible throughout, thus producing an inboard pull on the respective uprights.

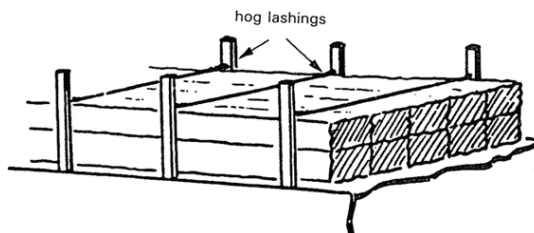

Figure 2.2 Example of hog lashings

2.10.15 In addition to uprights and hog lashings, an arrangement with top-over and continuous wiggle lashings (wiggle wires), as shown in the following figures, may be utilized at each hatch meeting the specifications of chapter 5.

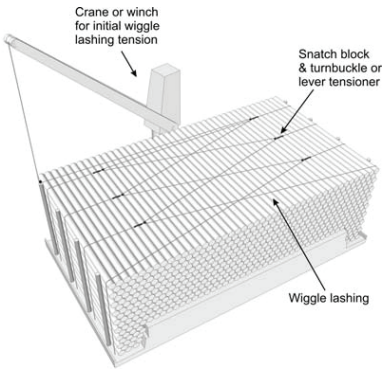

Figure 2.3. Example of wiggle lashings

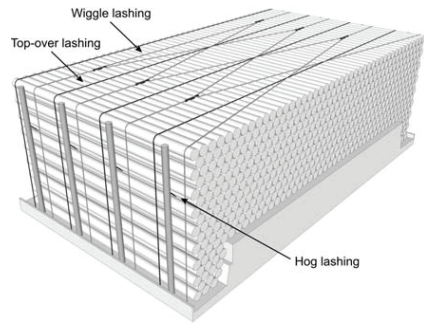

Figure 2.4. Example of an arrangement with hog, top-over and wiggle lashings*

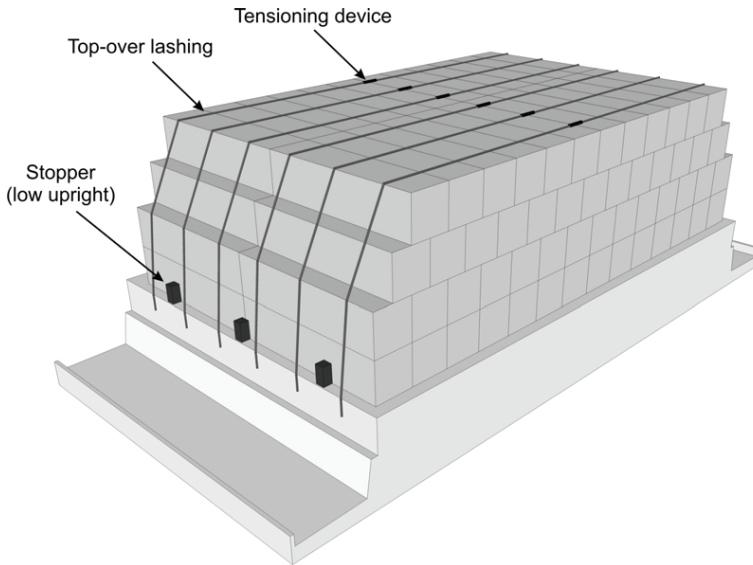

Figure 2.5. Example of an arrangement with top-over lashings and stoppers*

* Notwithstanding the guidance provided in these diagrams, compliance with the relevant timber Load Lines Convention provisions is required, when applicable.

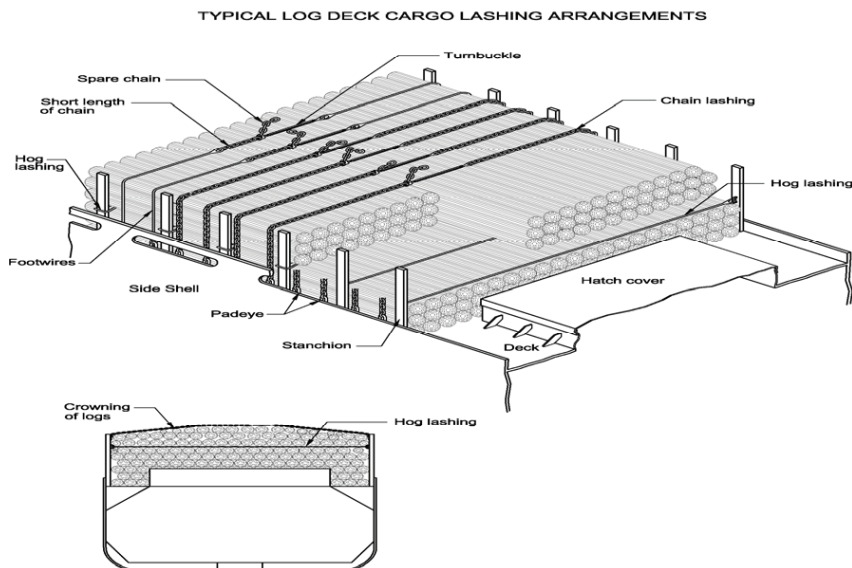

Figure 2.6. Example of chain top over lashings for a log cargo

2.10.16 If a wiggle wire is not fitted, then extra chain or chain/wire combination overlashings should be fitted instead, as described in 5.4.1.

2.11 Post-loading operation

The Company should establish procedures for the preparation of plans and instructions, including checklists as appropriate, for key post loading operations⁽⁵⁾.

2.12 Voyage planning

2.12.1 Prior to proceeding to sea, the master should ensure that the intended voyage has been planned using the appropriate nautical charts and nautical publications for the area concerned, taking into account the guidelines and recommendations developed by the Organization⁽²³⁾.

2.12.2 In order to reduce excessive accelerations, the master should plan the voyage so as to avoid potential severe weather and sea conditions. To this effect, weather reports, weather facsimiles or, where available, weather routing may be consulted and the latest available weather information should always be used⁽²⁴⁾.

2.12.3 If deviation from the intended voyage plan is considered during the voyage, the same procedure as described in 2.12.1 and 2.12.2 should be followed.

2.12.4 In cases where severe weather and sea conditions are unavoidable, the Master should be conscious of the need to reduce speed and/or alter course at an early stage in order to minimize the forces imposed on the cargo, structure and lashings. The lashings are not designed to provide a means of securing against imprudent ship handling in severe weather and sea conditions. There can be no substitute for good seamanship. The following precautions should be observed:

- .1 in the case of marked roll resonance with amplitudes above 30° to either side, the cargo securing arrangements could be overstressed. Effective measures should be taken to avoid this condition;
- .2 in the case of heading into the seas at high speed with marked slamming shocks, excessive longitudinal and vertical acceleration may occur. An appropriate reduction of speed should be considered; and
- .3 in the case of running before large stern or quartering seas with a stability which does not amply exceed the accepted minimum requirements, large roll amplitudes should be expected with great transverse accelerations as a result. An appropriate change of heading should be considered.

Foreseeable risks

2.12.5 During voyage planning, all foreseeable risks, which could lead to either excessive accelerations causing cargo to shift or conditions leading to water absorption and ice aggregation, should be considered. The following list comprises the most significant situations that should be taken under consideration to that effect:

- .1 extreme weather conditions predicted by weather forecasts;
- .2 severe wave conditions that have been known to appear in certain navigational areas;
- .3 unfavourable directions of encountered waves⁽²⁵⁾; and
- .4 swell caused by recent weather phenomena in the vicinity of the area of the intended voyage.

2.13 Cargo Securing Manual

2.13.1 Timber deck cargoes should be loaded, stowed and secured, throughout the voyage, in accordance with the Cargo Securing Manual as required by SOLAS chapter VI.

2.13.2 The Cargo Securing Manual should be based on the guidelines in this Code and drawn up to a standard at least equivalent to the guidelines developed by the Organization^{(26), (27)} and approved by the Administration⁽²⁶⁾.

2.13.3 Each cargo securing arrangement for timber deck cargoes should be documented in the ship's Cargo Securing Manual in accordance with the instructions in MSC/Circ.745.

2.13.4 According to the CSS Code and MSC/Circ.745, among others, the following parameters should be taken into account at the design stage of cargo securing systems:

- .1 duration of the voyage;
- .2 geographical area of the voyage;

- .3 sea conditions which may be expected;
- .4 dimensions, design and characteristics of the ship;
- .5 expected static and dynamic forces during the voyage;
- .6 type and packaging of cargo units;
- .7 intended stowage pattern of the cargo units; and
- .8 mass and dimensions of the cargo units.

2.13.5 In the Cargo Securing Manual, each stowage and securing arrangements should additionally be documented by a Lashing Plan showing at least the following:

- .1 maximum cargo weight for which the arrangement is designed;
- .2 maximum stowage height;
- .3 required number and strength of blocking devices and lashings as applicable;
- .4 required pretension in lashings;
- .5 other cargo properties of importance for the securing arrangement such as friction, rigidity of timber packages, etc.;
- .6 illustrations of all securing items that might be used; and
- .7 any restriction regarding maximum accelerations, weather criteria, for non-winter conditions only, restricted sea areas, etc.

CHAPTER 3 – VISIBILITY

3.1 According to SOLAS chapter V, the view of the sea surface from the conning position should not be obscured by more than two ship lengths, or 500 m, whichever is the less, forward of the bow to 10° on either side under all conditions of draught, trim and deck cargo. National deviations may exist and should be taken into consideration as required dependent on the intended voyage.

3.2 No blind sector, caused by cargo, cargo gear or other obstructions outside of the wheelhouse forward of the beam which obstructs the view of the sea surface as seen from the conning position, should exceed 10°. The total arc of blind sectors should not exceed 20°. The clear sectors between blind sectors should be at least 5°. However, in the view described in 3.1, each individual blind sector should not exceed 5°.

3.3 The following formula can be used for calculating the bridge visibility:

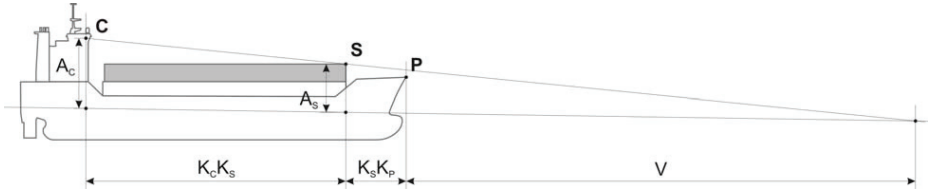

Figure 3.1. Distances used for calculating the bridge visibility

$$V = \frac{K_c K_s \cdot A_s}{A_c - A_s} - K_s K_p$$

Where:

- $K_c K_s$ Horizontal distance from conning position to position 'S'
- $K_s K_p$ Horizontal distance from position 'S' to position 'P'
- A_c Airdraft of conning position
- A_s Airdraft of position 'S'

CHAPTER 4 – PHYSICAL PROPERTIES OF TIMBER CARGOES

4.1 Stowage factors

4.1.1 Typical values for density and stowage factors are given in the table below for different types of timber deck cargoes.

Table 4.1. Typical values for density and stowage factors

Type of timber cargo	Density [ton / m ³]	Volume factor [m ³ hold space / m ³ cargo]	Stowage factor [m ³ hold space / ton of cargo]
Sawn wood			
Packages of sawn wood with even ends	0.5 – 0.8	1.4 -1.7	1.8 – 3.4
Packages of sawn wood with uneven ends	0.5 – 0.8	1.6 – 1.9	2.0 - 3.8
Packages of planed wood with even ends	0.5	1.2 – 1.4	2.4 - 2.8
Round wood			
Coniferous round wood, fresh (bark on)	0.9 – 1.1	1.5 - 2.0	1.4 - 2.2
Broad-leaf round wood, fresh (bark on)	0.9 – 1.5	2.0 - 2.5	1.3 - 2.8
Round wood, dried (bark on)	0.65	1.5 - 2.0	2.3 - 3.1
Debarked coniferous round wood, fresh	0.85 – 1.2	1.5 – 2.0	1.2 – 2.4
Debarked broad-leaf round wood, fresh	0.9 – 1.0	1.5 – 2.5	1.5 – 2.8
Debarked round wood, dried	0.6 – 0.75	1.2 – 2.0	1.6 – 3.3

4.1.2 The densities and stowage factors in the table above are presented for information purpose only to aid preplanning operations. The corresponding values for actual loads may vary significantly from those presented in the table depending on the timber type and condition. During actual loading more accurate values of the cargo weight are obtained by repeated checks of the vessel's displacement. The weights of sawn wooden packages are normally more accurate.

4.1.3 The weight of uncovered timber cargo may change during a voyage due to loss or absorption of water (but wrapped bundled cargoes do not). Timber cargo stowed under deck may lose weight whereas timber stowed on deck may gain weight by absorption of water, see special instruction in Annex C. Particular attention should be given to the impact that these and other changing conditions have on stability throughout a voyage.

4.2 Friction factors

4.2.1 Cargo at rest is prevented from sliding by static friction. When movement has been initiated the resistance of the material contact is reduced and sliding is counteracted by dynamic friction, see 4.2.6, instead.

4.2.2 The static friction may be determined by an inclination test. The angle ρ is measured when the timber cargo starts to slide. The static friction is calculated as:

$$\mu = \tan (\rho).$$

4.2.3 Five inclination tests should be performed with the same combination of materials. The highest and the lowest values should be disregarded and the friction factor is taken as the average of the three middle values. This average figure should be rounded down to the nearest fraction of 0.05.

4.2.4 If the values are intended to be used for non-winter conditions, the coefficient of friction for both dry and wet contact surfaces should be measured in separate series of tests and the lower of the two values are to be the used when designing cargo securing arrangements.

4.2.5 If the values are intended to be used for winter conditions when exposed surfaces are covered by snow and ice, the lowest coefficient of friction found for either dry, wet or snowy and icy contact surfaces should be used when designing cargo securing arrangements.

4.2.6 If not specially measured the dynamic friction factor may be taken as 70% of the static values.

4.2.7 The following values of static friction for the mentioned conditions may be used when designing securing arrangements for timber deck cargoes unless the actual coefficient of friction is measured and documented as described above.

Table 4.2. Typical values of static friction for different material combinations

Contact surface	Non-winter conditions <i>Dry or wet</i>	Winter conditions
Sawn wooden package		
<i>against</i> painted steel	0.45	0.05
<i>against</i> sawn wood	0.50	0.30
<i>against</i> plastic cover or webbing slings	0.30	0.25
Round wood		
coniferous round wood (bark on) <i>against</i> painted steel	0.35	
coniferous round wood (bark on) <i>between layers</i>	0.75	

4.2.8 Static friction may be used for tight block stowage arrangements as well as for the design of frictional lashing systems such as top-over lashing systems.

4.2.9 Dynamic friction should be used for non-rigid lashing systems, which due to elasticity of securing equipment allow for minor dislocation of the cargo before full capacity of the securing arrangement is reached.

4.3 Plastic covers

4.3.1 Plastic sheeting is often used on packages of sawn wood to protect the cargo. High friction coatings (friction coefficient 0.5 and above) can be incorporated into plastic sheeting as an important means of improving the safe transport of these cargoes.

4.3.2 Special precautions should be taken to prevent slippery plastic hoods with low friction coefficients, from being used as a sawn wood package cargo covering on deck.

4.4 Package marking

All sawn wooden packages should be clearly marked with the volume of the package. The marking should be clearly visible on the top of the package as well as both long sides. The approximate weight should also be shown⁽²⁹⁾.

4.5 Water absorption

Sea spray may increase the weight of the timber deck cargo and thus influence the stability. The weight increase of the timber varies with time, exposure and type of timber. The value of increased weight of timber deck cargo due to water absorption should be considered in accordance with the 2008 IS Code and special instructions in Annex C.

4.6 Weight of ice

During cold weather conditions ice may form from sea spray and the stability may be affected as the ice can add weight rapidly. The increase in weight due to icing should be considered in accordance with section 6.2 of the 2008 IS Code. The increases given in section 6.3 of that Code for fishing vessels may be considered to be suitable also for timber cargoes, particularly for small ships. Any increase in weight due to water absorption should be considered before calculating the increase due to the weight of ice.

4.7 Rigidity of sawn wood packages

4.7.1 The Racking Strength, RS, of a sawn wood package is defined as the horizontal force that a package can withstand per metre package length without collapsing or deforming more than 10% of its width, B, or a maximum of 100 mm as shown in figure 4.1.

4.7.2 The racking strength of timber packages can be measured by a test setup as shown in figure 4.2. The angle α should not be greater than 30°.

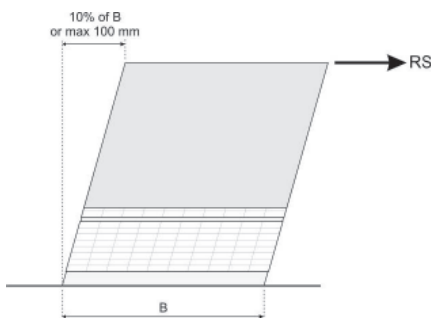

Figure 4.1. Racking strength of timber packages

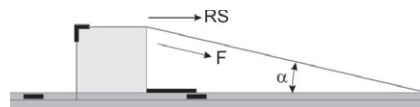

Figure 4.2. Test setup for racking strength

4.7.3 The Racking Strength, RS, is taken as the applied force $F \cdot \cos \alpha$ (see figure above) when the package collapses or when the deflection in the top is 10% of the package width, B, or maximum 100 mm.

4.7.4 Racking strength measurements will have to be carried out by the shipper and the information should be provided to the master as part of the required cargo information mentioned in SOLAS chapter VI.

PART B – DESIGN OF CARGO SECURING ARRANGEMENTS

To accommodate proven designs and practices but to also embrace advances in technology and materials, part B has been split into two chapters, each providing different design principles. Chapter 5: (Design Principles) incorporates **prescriptive** requirements. Chapter 6: (Alternative Design Principles) provides for alternative designs and equipment to be developed and includes **functional** requirements.

CHAPTER 5 – DESIGN PRINCIPLES

This chapter applies primarily, but is not limited to, ships of 24 metres in beam and above engaged in international deep-sea trade and incorporates experience-based prescriptive requirements on the securing of timber deck cargoes. It primarily applies the use of steel components for lashings but is not limited to their sole use. Consideration may be given to allowing chapter 5 ships to make use of proven alternative technologies in cargo securing design, which provide at least the level of safety as specified in this chapter. Details of such alternatives should be included in the ship's Cargo Securing Manual.

5.1 General

5.1.1 Every lashing should pass over the timber deck cargo and be secured to suitable eyeplates, lashing bollards or other devices adequate for the intended purpose which are efficiently attached to the deck stringer plate or other strengthened points. They should be installed in such a manner as to be, as far as practicable, in contact with the timber deck cargo throughout its full height.

5.1.2 All lashings and components used for securing should:

- .1 possess a breaking strength of not less than 133 kN;
- .2 after initial stressing, show an elongation of not more than 5% at 80% of their breaking strength; and
- .3 show no permanent deformation after having been subjected to a proof load of not less than 40% of their original breaking strength.

5.1.3 Every lashing should be provided with a tightening device or system so placed that it can safely and efficiently operate when required. The load to be produced by the tightening device or system should not be less than:

- .1 27 kN in the horizontal part; and
- .2 16 kN in the vertical part.

5.1.4 Upon completion and after the initial securing, the tightening device or system should be left with no less than half the threaded length of screw or of tightening capacity available for future use.

5.1.5 Every lashing should be provided with a device or an installation to permit the length of the lashing to be adjusted.

5.1.6 The spacing of the lashings should be such that the two lashings at each end of each length of continuous deck stow are positioned as close as practicable to the extreme end of the timber deck cargo.

5.1.7 If wire rope clips are used to make a joint in a wire lashing, the following conditions should be observed to avoid a significant reduction in strength:

- .1 the number and size of rope clips utilized should be in proportion to the diameter of the wire rope and should not be less than three, each spaced at intervals of not less than 150 mm;
- .2 the saddle portion of the clip should be applied to the live load segment and the U-bolt to the dead or shortened end segment; and
- .3 rope clips should be initially tightened so that they visibly compress the wire rope and subsequently be re-tightened after the lashing has been stressed.

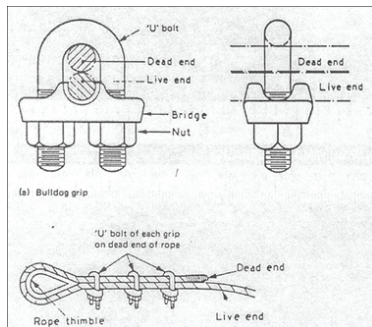

Figure 5.1. Wire rope clips

5.1.8 Greasing the threads of grips, clips, shackles and turnbuckles increases their holding capacity and prevents corrosion.

5.1.9 Bulldog grips are only suitable for a standard wire rope of right-hand lay having six strands. Left-hand lay or different construction should not be used with such grips.

5.2 Uprights

5.2.1 Uprights, designed in accordance with chapter 7, should be used when required by the nature, height or character of the timber deck cargo as outlined in this code.

5.2.2 When uprights are used, they should:

- .1 be made of material of adequate strength, taking into account relevant parameters such as; the breadth of the deck cargo, the weight and height of the cargo, the type of timber cargo, friction factors, additional lashings, etc.;

- .2 be spaced at intervals between the centrelines of two uprights not exceeding 3 m so that preferably all sections of the stow are supported by at least two uprights; and
- .3 be fixed to the deck and/or hatch cover by angles, sockets or equally efficient means and be secured in position as required by the CSM.

5.3 Loose or packaged sawn wood

5.3.1 Uprights should be used for loose sawn wood. Uprights or stoppers (low uprights) should also be used to prevent packaged sawn wood loaded on top of the hatch covers only from sliding. The timber deck cargo should in addition be secured throughout its length by independent lashings.

5.3.2 Subject to 5.3.3, the maximum spacing of the lashings referred to above should be determined by the maximum height of the timber deck cargo in the vicinity of the lashings:

- .1 for a height of 2.5 m and below, the maximum spacing should be 3 m;
- .2 for heights of above 2.5 m, the maximum spacing should be 1.5 m; and
- .3 on the foremost and aft-most sections of the deck cargo the distance between the lashings according to above should be halved.

5.3.3 As far as practicable, long and sturdy packages should be stowed in the outer rows of the stow and the packages stowed at the upper outboard edge should be secured by at least two lashings each.

5.3.4 When the outboard packages of the timber deck cargo are in lengths of less than 3.6 m, the spacing of the lashings should be reduced as necessary or other suitable provisions made to suit the length of timber.

5.3.5 Rounded angle pieces of suitable material and design should be used along the upper outboard edge of the stow to bear the stress and permit free reeving of the lashings.

5.3.6 Timber packages may alternatively be secured by a chain or wire loop lashing system, based on the design principles contained in chapter 6.

5.4 Logs, poles, cants or similar cargo

5.4.1 The round wood deck cargo should be supported by uprights and secured throughout its length by independent top-over or loop lashings spaced not more than 1.5 m apart.

5.4.2 If the round wood deck cargo is stowed over the hatches and higher, it should, in addition to being secured by the lashings recommended in 5.4.1, be further secured by a system of athwartship lashings (hog lashings as described in section 2.10.14) joining each port and starboard pair of uprights.

5.4.3 If winches or other adequate tensioning systems are available on board, every other of the lashings mentioned in 5.4.1 may be connected to a wiggle wire system as described in section 2.10.15.

5.4.4 The recommendation of 5.3.5 should apply to a timber deck cargo of cants.

5.5 Testing, marking, examination and certification

All lashings and components used for the securing of the timber deck cargo should be tested, marked, examined and certified, as per the guidelines in MSC/Circ.745⁽²⁷⁾, and be specific to the requirements for lashing and components outlined in 5.1.2 and 5.1.3.

5.6 Lashing plans

One or more generic lashing plans complying with the recommendations of this Code should be provided and maintained on board a ship carrying timber deck cargo. Lashing plans should be incorporated in the Cargo Securing Manual and the most relevant lashing plan should be consulted when stowing and securing timber deck cargoes.

CHAPTER 6 – ALTERNATIVE DESIGN PRINCIPLES

This chapter permits the development (and use) of new designs and securing arrangements by providing functional based requirements on the securing of timber deck cargoes, which may be used as an alternative to the requirements in chapter 5 for ships of less than 24 metres in beam and for designers considering alternative technologies in cargo securing. Any design risk assessment should be agreed with the Administration before being used. When this chapter is applied, operational risk assessments should be included within the ship's safety management system.

6.1 General requirements

6.1.1 The construction of deck, bulwarks, uprights, hatches and coamings should be of a design that allows a load of timber deck cargo to be carried in a satisfactory manner.

6.1.2 The goal is to prevent cargo shifting as far as practicable and the securing system should be designed according to the principles laid down in this chapter.

6.1.3 Loose sawn or round wood should as a general rule be longitudinally stowed and supported on the sides by uprights to the full height of the stow.

6.1.4 Packaged sawn wood deck cargoes may be secured without uprights if the racking strength of the packages has been tested and found sufficient and sliding is prevented by bottom blocking, friction or lashing.

6.1.5 If the friction is sufficient and the expected transverse accelerations are limited, unpackaged sawn wood cargo may be transversely stowed.

6.1.6 All denotations used in the formulae in this chapter are listed in section 6.7 of this Code.

6.2 Accelerations and forces acting on the cargo

6.2.1 The cargo securing arrangement should in the transverse direction be designed for accelerations generated as well as forces by wind and sea according to the CSS Code, Annex 13.

6.2.2 Special securing of timber deck cargoes in the longitudinal direction may be dispensed with only if great care is taken to avoid excessive acceleration forces in heavy head seas.

6.2.3 To take account of the factors mentioned in 2.13.4, the acceleration data calculated according to Annex 13 of the CSS Code may be multiplied by a reduction factor ranging from 0 to 1, depending on expected maximum significant wave height during the intended voyage. The reduction factor is obtained by the following formula:

$$f_R = \sqrt[3]{\frac{H_M}{19.6}}$$

Where the variable H_M means the maximum expected significant wave height in metres.

(The value 19.6 is the assumed twenty year wave that will occur in the Northern Atlantic Ocean. Relevant significant wave heights for different sea areas and seasons can be obtained from "Ocean Wave Statistics".)

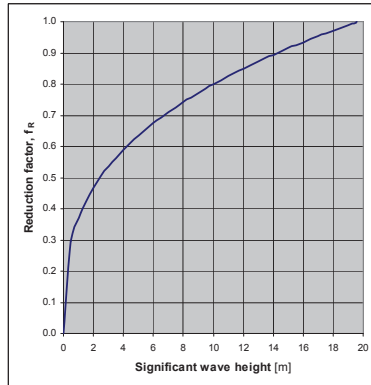

Figure 6.1. Plot of the reduction factor as a function of the expected significant wave height

6.2.4 Reduced acceleration may be used for the design of securing arrangements for timber deck cargoes in any of the following ways:

- .1 Required securing arrangements are designed for different wave heights and the securing arrangement is selected according to the maximum expected wave height for each voyage.
- .2 The maximum wave height that a particular securing arrangement can withstand is calculated and the vessel is limited to operate in wave heights up to the maximum calculated. Examples on such arrangements are unsecured transversely stowed timber deck cargoes in restricted sea areas.
- .3 The required securing arrangement is calculated for the maximum expected twenty year wave in a particular restricted area and the cargo is always secured according to the designed arrangement when operating in that area.

6.2.5 If one of the two first mentioned methods in 6.2.4 are used for decision on securing arrangements, it is important that procedures for forecasting the maximum expected wave height on intended voyages is developed and followed and documented in the ship's approved Cargo Securing Manual.

6.3 Physical properties of timber deck cargoes

6.3.1 Prior to loading of timber deck cargoes, all relevant cargo information, as described in this section and in chapter 4, should be provided to the master of the vessel.

Friction

6.3.2 Friction is one of the most important factors preventing cargo from shifting. Deck cargo may shift due to a lack of internal friction. Snow, ice, frost, rain, and other slippery surface conditions drastically affect friction. Special consideration should be given to package materials, contact surfaces, and weather conditions.

6.3.3 Static friction may be used for tight block stowage arrangements as well as for the design of frictional lashing systems such as top-over lashing systems.

6.3.4 Dynamic friction should be used for non-rigid lashing systems, e.g. loop lashings, which due to elasticity of securing equipment allow for minor dislocation, see 6.5.16, of the cargo before full capacity of the securing arrangement is reached.

6.3.5 Test procedures for determining coefficients of friction as well as generic friction values for material contacts common for timber deck cargoes are given in chapter 4.

Rigidity of timber packages

6.3.6 The rigidity of timber packages is of great importance for the stability of the deck cargo and the racking strength of the timber packages should be taken into consideration when securing systems are designed.



Figure 6.2. Example of poor rigidity

6.3.7 The definition of the rigidity of timber packages for the purpose of this Code as well as methods for determining it are presented in chapter 4. The racking strength should not be less than 3.5 kN/m of package length.

6.4 Safety factors

6.4.1 Safety factors are to be used when:

- .1 calculating the Maximum Securing Load (MSL) of the lashings from the Minimum Breaking Load (MBL); and
- .2 calculating the maximum allowed Calculated Strength (CS) in the lashings as function of MSL.

6.4.2 MSL as function of the MBL should be taken according to Annex 13 of the CSS Code, provided inspection and maintenance of the equipment have been carried out in accordance with the ship's Cargo Securing Manual.

6.4.3 The maximum allowed Calculated Strength (CS) in lashings and uprights used in the calculations should be taken from the following formula:

$$CS \leq \frac{MSL}{1.35}$$

6.5 Design criteria for different securing arrangements

6.5.1 Securing arrangements for timber deck cargoes should be based on accelerations, physical properties and safety factors as described in 6.4 above.

6.5.2 Design criteria for some different securing arrangements are given below. Other securing arrangements may also be used as long as the system is designed according to the principles given in this code.

6.5.3 In Annex B detailed descriptions and example design calculations are given for some stowage and securing arrangements.

6.5.4 The denotations used in the formulas in this chapter are listed in chapter 8.

Top-over lashed longitudinally stowed timber packages

6.5.5 Top-over lashing alone is a frictional lashing method and the effect of the lashing is to apply vertical pressure increasing the friction force between the outer stows of deck cargo and the ship's deck/hatch cover.

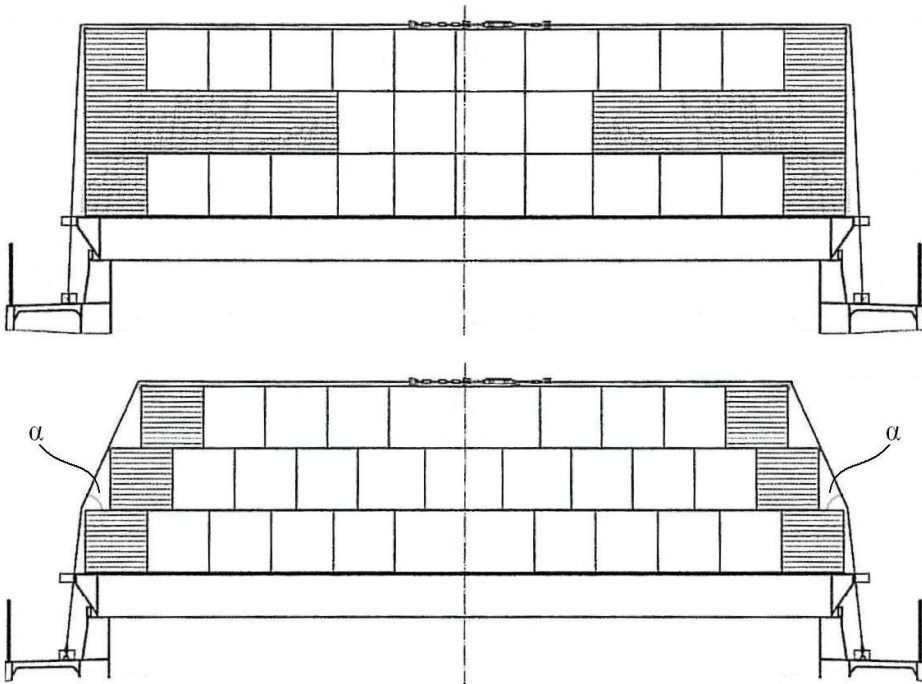

Figure 6.3. Principles for top-over lashing

6.5.6 For pure top-over lashing arrangements the friction alone will have to counteract the transverse forces so that the following equilibrium of forces is satisfied:

$$(m \cdot g_0 + 2 \cdot n \cdot PT_V \cdot \sin \alpha) \cdot \mu_{static} \geq m \cdot a_t + PW + PS$$

6.5.7 In practice, sliding between the layers is often prevented due to slightly different heights of the timber packages. Alternatively it may be prevented by inserting vertical sturdy battens of proper dimensions between the columns.

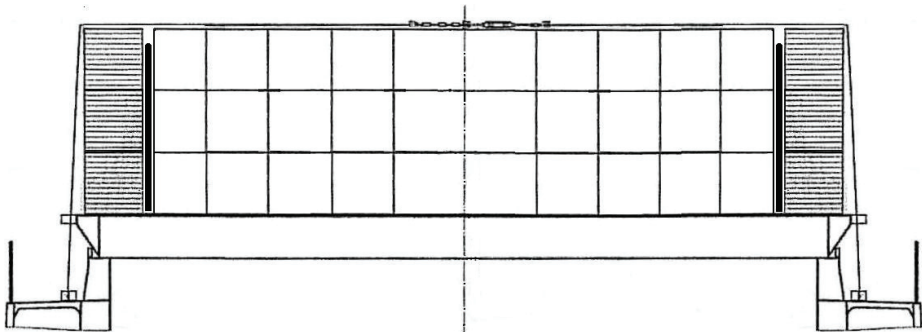

Figure 6.4. Sliding of upper layer prevented by vertical sturdy battens

6.5.8 If sliding between layers is not prevented, sliding between each individual layer should be considered by the following equilibrium of forces:

$$(m_a \cdot g_0 + 2 \cdot n \cdot PT_V \cdot \sin \alpha) \cdot \mu_{static\ a} \geq m_a \cdot a_t + PW_a + PS_a$$

Units denoted with _a consider cargo units above the sliding level only.

6.5.9 To prevent the packages in the bottom layer from collapsing due to racking, the weight of the cargo stowed on top of the bottom layer should be limited so that the following equilibrium of forces is satisfied:

$$n_p \cdot L \cdot RS \geq m_a \cdot (a_t - 0.5g_0) + PW_a + PS_a$$

Units denoted with _a consider cargo units above the bottom layer only.

6.5.10 Lashings used should comply with 6.5.20 and 6.5.21. It is extremely important to keep the lashings tight when a top-over lashing arrangement is used as the arrangement is based on the vertical pressure from the lashings.

6.5.11 When top-over lashings are used as the only means of securing longitudinally stowed packages of sawn wood, adequate friction against the hatch covers should be sought and/or the transverse accelerations should if possible be limited.

Loop lashed longitudinally stowed timber packages

6.5.12 Loop lashings are always applied in pairs as shown in the figure below. The lashings are drawn from one side of the cargo, under the cargo to the other side, up over the cargo and back to the same side. Alternatively, the lower part of the lashing may be fastened to a securing point on top of the hatch cover underneath the cargo.

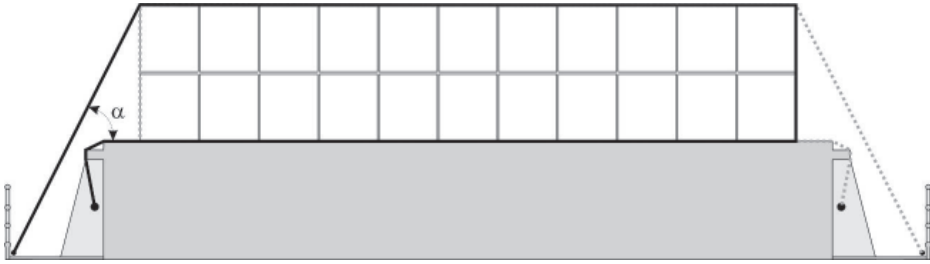

Figure 6.5. Principles of loop lashing alternative 1 (be aware of chafing where lashings are lead around ship's structure as shown in the above figure, see section 2.10.10)

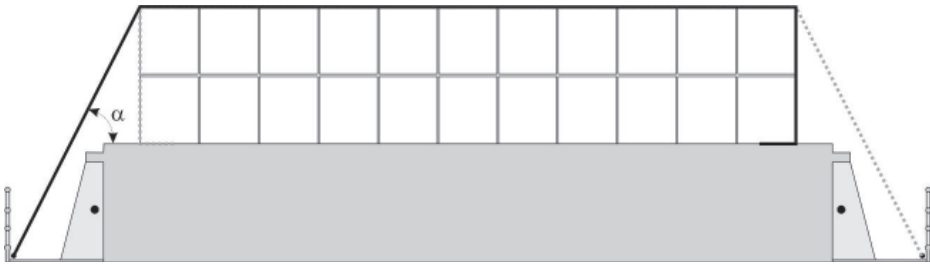

Figure 6.6. Principles for loop lashing alternative 2. The shorter length of the lashing compared to alternative 1 reduces the movement of the cargo due to elongation of the lashing

6.5.13 The number and strength of the lashings are to be chosen so that the following equilibrium is satisfied:

$$(m \cdot g_0 + n \cdot CS \cdot \sin \alpha) \cdot \mu_{dynamic} + n \cdot CS + n \cdot CS \cdot \cos \alpha \geq m \cdot a_t + PW + PS$$

6.5.14 Sliding between the layers should be prevented (see 6.5.7).

6.5.15 To prevent the packages in the bottom layer from racking, the weight of the cargo stowed on top of the bottom layer should be limited so that the following equilibrium is satisfied:

$$n_p \cdot L \cdot RS + n \cdot CS \cdot \cos \alpha \geq m_a \cdot (a_t - 0.5g_0) + PW_a + PS_a$$

Units denoted with _a consider cargo units above the bottom layer only.

6.5.16 The transverse movement of the deck cargo due to elongation of the lashings is calculated according to the following formula:

$$\delta = L_L \cdot \frac{(CS - PT_V)}{MSL} \cdot \varepsilon$$

The elongation factor ε should be taken as 2% for chain and wire lashings and 7% for web lashings unless otherwise specified by certificate from the manufacturer.

The maximum heeling angle of the vessel due to a small transverse movement of the cargo should in no case be more than 5°, based on the full timber deck load condition of the vessel calculated according to the following formula:

$$HA = \arctan\left(\frac{HM}{G'M \cdot \Delta}\right)$$

Where:

HA = Heeling angle in degrees

HM = Heeling moment due to transverse movement of the deck cargo in ton-metres

G'M = Metacentric height corrected for free surface moments in metres

Δ = Ship's actual displacement in tons

Bottom blocked and top-over lashed longitudinally stowed timber packages

6.5.17 Blocking means that the cargo is stowed against a blocking structure or fixture on the ship. If the cargo consists of packages with large racking capacity, bottom blocking should be sufficient in combination with top-over lashings.



Figure 6.7. Example of uprights for bottom blocking

6.5.18 The required strength, MSL, of the bottom blocking devices is calculated by satisfying the following equilibrium:

$$(m \cdot g_0 + 2 \cdot n \cdot PT_V \cdot \sin \alpha) \cdot \mu_{static} + n_b \cdot \frac{MSL}{1.35} \geq m \cdot a_t + PW + PS$$

6.5.19 The spacing between top-over lashings in a longitudinal direction should be maximum 3 m for stowage heights below 2.5 m and maximum 1.5 m for stowage heights above 2.5 m.

6.5.20 The pretension PT_V in the vertical part of the lashings should be not less than 16 kN and the pretension PT_H in the horizontal part of the lashing should not be less than 27 kN.

6.5.21 All lashings and components used for securing in combination with bottom blocking should:

- .1 possess a breaking strength MBL of not less than 133 kN;
- .2 after initial stressing, show an elongation of not more than 5% at 80% of their breaking strength; and
- .3 show no permanent deformation after having been subjected to a proof load of not less than 40% of their original breaking strength.

6.5.22 The bottom blocking devices are to be placed on both sides of the deck cargo equally spaced. Two blocking device per side should be used per cargo section and the height should extend to a height of at least 200 mm.

6.5.23 Sliding between the layers should be prevented (see 6.5.7). If no such measures are taken, sliding between layers should be checked by the calculation for equilibrium of forces in 6.5.8.

6.5.24 To prevent the packages in the bottom layer from racking, the weight of the cargo stowed on top of the bottom layer should be limited so that the following equilibrium of forces is satisfied:

$$n_p \cdot L \cdot RS \geq m_a \cdot (a_t - 0.5g_0) + PW_a + PS_a$$

Units denoted with _a consider cargo units above the bottom layer only.

Uprights blocked and top-over lashed longitudinally stowed sawn wood packages and round wood

6.5.25 Longitudinally stowed sawn wood packages, loose sawn wood or round wood may be supported by uprights in combination depending on trading pattern with or without top-over lashings or hog wires.

6.5.26 The uprights should be designed in accordance with chapter 7.

6.5.27 The uprights should be placed on both sides of the cargo, equally spaced. Each cargo block of the stow should be supported by at least two uprights per side.

6.5.28 The spacing of top-over lashings should for packaged sawn wood be a maximum of 3 m for stowage heights below 2.5 m and maximum 1.5 m for stowage heights above 2.5 m for round wood the spacing should be 1.5 m irrespective of the height.

6.5.29 The pretension PT_V in the vertical part of the lashings should be not less than 16 kN and the pretension PT_H in the horizontal part of the lashing should not be less than 27 kN.

6.5.30 All lashings and components used for securing in combination with bottom blocking should:

- .1 possess a breaking strength MBL of not less than 133 kN;
- .2 after initial stressing, show an elongation of not more than 5% at 80% of their breaking strength; and

- .3 show no permanent deformation after having been subjected to a proof load of not less than 40% of their original breaking strength.

Frictional securing

6.5.31 In restricted sea areas, round wood may be transversely stowed and secured by bottom blocking and/or friction between tiers only. This may be done only if the friction between layers is sufficient and the expected transverse accelerations are limited. When the friction is sufficient between bottom layers and deck/hatch, then the bottom blocking may not be required. If friction only is to be used, information on the maximum heel angle assumed should be included in the Cargo Securing Manual.

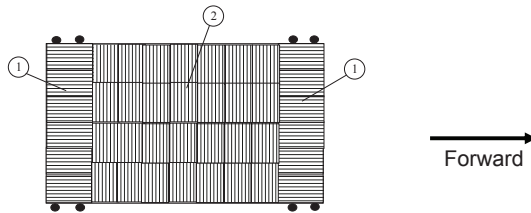

Example of round wood stowage pattern for restricted sea areas. Sections marked 1 are longitudinally stowed round wood secured by uprights. Section marked 2 are transversely stowed round wood secured by friction in combination with or without bottom blocking.

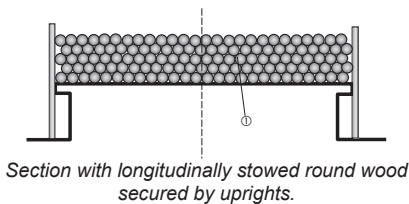

Section with longitudinally stowed round wood secured by uprights.

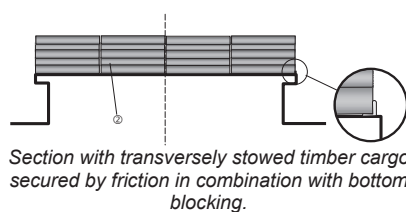

Section with transversely stowed timber cargo secured by friction in combination with bottom blocking.

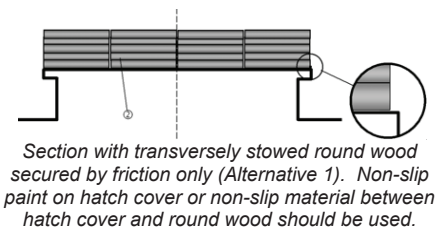

Section with transversely stowed round wood secured by friction only (Alternative 1). Non-slip paint on hatch cover or non-slip material between hatch cover and round wood should be used.

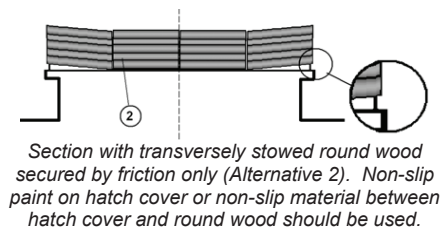

Section with transversely stowed round wood secured by friction only (Alternative 2). Non-slip paint on hatch cover or non-slip material between hatch cover and round wood should be used.

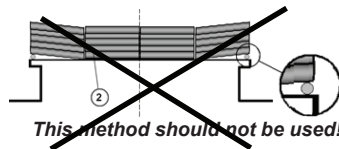

This method should not be used!

Section with transversely stowed round wood secured by friction only (Alternative 3).

Figure 6.8. Principles for friction securing of round wood in restricted sea areas

6.5.32 The required strength, MSL, of the bottom blocking devices is calculated by satisfying the following equilibrium:

$$m \cdot g_0 \cdot \mu_{static} + n_b \cdot \frac{MSL}{1.35} \geq m \cdot a_t + PW + PS$$

6.5.33 The required friction between the layers can be calculated by satisfying the following equilibrium:

$$m \cdot g_0 \cdot \mu_{static} \geq m \cdot a_t + PW + PS$$

CHAPTER 7 – UPRIGHTS

7.1 Longitudinally stowed round wood, loose sawn wood and sawn wood packages with limited racking strength should be supported by uprights at least as high as the stow.

7.2 Uprights should be designed for the forces they have to take up according to the formulas in this section. The connection of uprights to the deck or hatch is to be to the satisfaction of the Administration. The design of high uprights especially should be such that the deflection is limited. Uprights may be complemented by different lashing arrangements.



Figure 6.9. Uprights for blocking over the entire height of the stow

7.3 For vessels carrying loose sawn wood and round timber, the design bending moment per upright is calculated as the greater of the two moments given by the following formulas:

$$CM_{bending1} = 0.1 \cdot \frac{H^2}{k \cdot B \cdot N} \cdot m \cdot g_0$$

$$CM_{bending2} = \frac{H}{3 \cdot k \cdot N} \cdot (m \cdot (a_t - 0.6 \cdot \mu_{static} \cdot g_0) + PW + PS)$$

$$M_{bending} \geq 1.35 \cdot \max(CM_{bending1}, CM_{bending2})$$

If **top-over lashings** are applied in accordance with sections 5.4 or 6.5.28 – 6.5.30, the bending moment of the uprights may be reduced by 12%.

7.4 The design bending moment per upright supporting timber packages is to be taken as the greatest of the three moments given by the following formulas:

$$CM_{bending1} = \frac{m}{n_p \cdot k \cdot N} \cdot \left(a_t \cdot \frac{H}{2} - g_0 \cdot \frac{b}{2} \right) \cdot \frac{1 - (1 - f_i)^n}{f_i} \quad (\text{Moment required to prevent tipping})$$

where: $f_i = \mu_{internal} \cdot \frac{2b}{H}$ (f_i = Factor for considering internal moment)

* The factor 0.6 in the formula above is used for considering both rolling and sliding movement of round wood and has been determined through practical tests. It should not be confused with the dynamic friction factor referred to in paragraph 4.2.6.

$$CM_{bending2} = \frac{H}{2 \cdot k \cdot N} \cdot m \cdot (a_t - \mu_{internal} \cdot g_0) \cdot \frac{q-1}{2q} \quad (\text{Moment required to prevent sliding})$$

$$CM_{bending3} = \frac{H}{k \cdot N} \cdot (m \cdot a_t - (n_p - 4)(q - 2) \cdot L \cdot RS) \cdot \frac{q-1}{2q} \quad (\text{Moment required to prevent racking})$$

$$M_{bending} \geq 1.35 \cdot \max(CM_{bending1}, CM_{bending2}, CM_{bending3})$$

7.5 If hog lashings are used, the required MSL of each hog lashing is calculated by the following formula:

$$MSL \geq \frac{M_{bending}}{2 \cdot h}$$

7.6 The design bending moment should not produce greater stress than 50% of the ultimate stress for the material in any part of the uprights.

CHAPTER 8 – DENOTATIONS USED

The denotations used in the formulas in the design criteria of this code are listed below:

a_t	=	Largest transverse acceleration at the centre of gravity of the deck cargo in the forward or aft end of the stow in m/s^2
B	=	Width of deck cargo in metres
b	=	Width of each individual stack of packages
CS	=	Calculated strength of lashing in kN, see section 6.4
f_R	=	Reduction factor for accelerations due to expected sea state
g_0	=	Gravity acceleration $9.81 m/s^2$
H	=	Height of deck cargo in metres
H_M	=	Maximum significant wave height
h	=	Height above deck at which hoglashings are attached to the uprights in metres
k	=	Factor for considering hog lashings: k = 1 if no hog lashings are used k = 1.8 if hog lashings are used
L	=	Length of the deck cargo or section to be secured in metres
L_L	=	Length of each lashing in metres
$M_{bending}$	=	Design bending moment on uprights in kNm
MSL	=	Maximum Securing Load in kN of cargo securing devices
m	=	Mass of the deck cargo or section to be secured in tonnes, including absorbed water and possible icing
N	=	Number of uprights supporting the considered section on each side
n	=	Number of lashings
n_b	=	Number of bottom blocking devices per side of the deck cargo
n_p	=	Number of stacks of packages abreast in each row
PS	=	Pressure from unavoidable sea sloshing in kN based on $1 kN$ per m^2 exposed area, see CSS Code, Annex 13
PT_V	=	Pretension in the vertical part of the lashings in kN
PT_H	=	Pretension in the horizontal part of the lashings in kN
PW	=	Wind pressure in kN based on $1 kN$ per m^2 wind exposed area, see CSS Code, Annex 13
q	=	Number of layers of timber packages
RS	=	Racking Strength per metre of timber package in kN/m, see section 4.7
α	=	Angle between the hatch cover top plating and the lashings in degrees
δ	=	Small transverse movement of deck cargo in metres due to elasticity of lashing arrangement
ε	=	Elasticity factor for lashing equipment, taken as fraction of elongation experienced at the load of MSL for the lashing
$\mu_{dynamic}$	=	Dynamic coefficient of friction between the timber deck cargo and the ship's deck/hatch cover and considered to be 70% of the static friction value
$\mu_{internal}$	=	Coefficient of dynamic friction found internally between the packages of sawn wood
μ_{static}	=	Static coefficient of friction between the timber deck cargo and the ship's deck/hatch cover

ANNEX A – GUIDANCE IN DEVELOPING PROCEDURES AND CHECKLISTS

Items in A.1 to A.5 should be taken into account when developing the checklists for timber deck cargo operations.

A.1 Preparations before loading of timber deck cargoes

General preparations

A.1.1 The following information as applicable for each parcel of cargo should be provided by the shipper and collected by the master or his representative:

- .1 total amount of cargo intended as deck cargo;
- .2 typical dimensions of the cargo;
- .3 number of bundles;
- .4 density of the cargo;
- .5 stowage factor of the cargo;
- .6 racking strength for packaged cargo;
- .7 type of cover of packages and whether non-slip type; and
- .8 relevant coefficients of friction including covers of sawn wooden packages if applicable.

A.1.2 A confirmation on when the deck cargo will be ready for loading should be received.

A.1.3 A pre-loading plan according to the ship's Trim and Stability Book should be done and the following should be calculated and checked:

- .1 stowage height;
- .2 weight per m²;
- .3 required amount of water ballast; and
- .4 displacement, draught, trim and stability at departure and arrival.

A.1.4 The stability should be within required limits during the entire voyage.

A.1.5 When undertaking stability calculations, variation in displacement, centre of gravity and free surface moments due to the following factors should be considered:

- .1 absorption of water in timber carried as timber deck cargo according to special instruction, see annex c;
- .2 ice accretion, if applicable;
- .3 variations in consumables; and
- .4 ballast water exchange operations, in accordance with approved procedures.

A.1.6 Proper instructions for ballast water exchange operations, if applicable for the intended voyage, should be available in the Ballast Water Management Plan.

A.1.7 A lashing plan according to the ship's Cargo Securing Manual (CSM) should be prepared and the following calculated:

- .1 weight and height of stows per hatch;
- .2 number of sections in longitudinal direction per hatch;
- .3 required number of pieces of lashing equipment; and
- .4 required number of uprights, if applicable.

A.1.8 The certificates for the lashing equipment should be available in the ship's Cargo Securing Manual.

A.1.9 When the initial stability calculations and lashing plan have been satisfactorily completed, the maximum cargo intake should be confirmed.

A.1.10 Pre-load, loading and pre-lashing plans should be distributed to all involved parties (i.e. supercargo, stevedores, agent, etc.).

A.1.11 Weather report for loading period and forecasted weather for the sea voyage should be checked.

A.1.12 It should be confirmed that the stevedoring company is aware of the ship's specific requirements regarding stowage and securing of timber deck cargoes.

Ship readiness

A.1.13 All ballast tanks required for the voyage and included in the stability calculations should be filled before the commencement of loading on deck and it should be ensured that free surfaces are eliminated in all tanks intended to be completely full or empty.

A.1.14 Hatch covers and other openings to spaces below deck should be closed, secured and battened down.

A.1.15 Air pipes, ventilators, etc., should be protected and examined to ascertain their effectiveness against entry of water.

A.1.16 Objects which might obstruct cargo stowage on deck should be removed and secured safely in places appropriate for storage.

A.1.17 Accumulation of ice and snow on areas to be loaded and on packaged timber should be removed.

A.1.18 All sounding pipes on the deck should be reviewed and necessary precautions should be taken that safe access to these remains.

A.1.19 Cargo securing equipment should be examined in preparation for use in securing of timber deck cargoes and any defective equipment found should be removed from service, tagged for repair and replaced.

A.1.20 It should be confirmed that uprights utilized are in compliance with the requirements in the ship's Cargo Securing Manual.

A.1.21 A firm and level stowage surface should be prepared. Dunnage, where used, should be of rough lumber and placed in the direction which will spread the load across the ship's hatches or main deck structure and assist in draining.

A.1.22 Extra lashing points, if required, should be approved by the Administration.

A.1.23 It should be ensured that dunnage is readily available and in good condition.

A.1.24 Friction enhancing arrangements, where fitted, should be checked for their condition.

A.1.25 Cranes with wires, brakes, micro switches and signals (if they are to be used) should be controlled.

A.1.26 It should be verified that illumination on deck is working and ready for use.

Ship to shore communication

A.1.27 Radio channels to be used during cargo operations should be assigned and tested.

A.1.28 It should be confirmed that crane drivers and loading stevedores/crew understand signals to be used during cargo operations.

A.1.29 A plan should be worked out to halt loading or unloading operations due to any unforeseen circumstances that may jeopardize safety of ship and/or anyone on board.

A.2 Safety during loading and securing of timber deck cargoes

Lashing equipment

A.2.1 If applicable, uprights should be mounted before loading on deck is commenced.

A.2.2 It should be checked that all lashing equipment is in place.

Ship's safety

A.2.3 All loading operations should be planned to immediately cease if a list develops for which there is no satisfactory explanation.

A.2.4 In the event that the vessel takes up an unexplained list, then no further work should be undertaken until all ship's tanks are sounded and assessment made of the ship's stability condition.

A.2.5 If deemed necessary, samples of the timber cargo should be weighed during loading and their actual weight should be compared to the weight stated by the shipper, in order to correctly assess the ship's stability.

A.2.6 Draught checks should be regularly carried out during the course of loading and the ship's displacement should be calculated to ensure the ship's stability and draft in the final condition are within prescribed limits.

A.2.7 Permitted loading weights on deck and hatches should not be exceeded.

A.2.8 The stability of the ship should at all times be positive and in compliance with the ship's intact stability requirements.

A.2.9 Emergency escape routes should be free and ready for use.

A.2.10 There should be free access to ventilation ducts and valves if required.

A.2.11 Obstructions, such as lashings or securing points, in the access way of escape routes or operational spaces and to safety equipment, fire-fighting equipment or sounding pipes should be avoided. Where they are unavoidable they should be clearly marked⁽¹¹⁾.

A.2.12 Instructions on how to calculate the GM of the vessel will be provided in the approved stability manual and these instructions should be followed to determine the GM of the ship. An approximation of the GM may be obtained (when safe to do so) from the rolling period or static list at a late stage of loading. Rolling or static list may be initiated by quick or slow (as appropriate) shifting of cargo with the deck cranes or lowering cargo bundles onto other deck cargo at one side of the ship.

Stowage

A.2.13 The stow of the deck cargo should be as solid, compact and stable as practicable. Slack in the stow should be prevented as such could cause lashings to slacken and/or water to accumulate.

A.2.14 A binding effect should, as far as practicable, be obtained within the stow to enhance the stability of stack structure and to minimize the risk of cargo shifting during the sea voyage.

A.2.15 Stowage of damaged timber packages should not be allowed. Timber packages that have deformed or are found with broken bands should be returned to shore for rectification.

A.2.16 Cargo should not be stowed overhanging the ship's side.

A.2.17 Timber deck cargo which overhangs the outer side of hatch coamings or other structures, should be supported at the outer end by other cargo stowed on deck or railing or equivalent structure of sufficient strength to support it (refer to 2.9.6).

Avoid the risk of sliding in the stow

A.2.18 Ice and snow accretions should be cleared from the hatches and deck cargo before placing further cargo layers in order to obtain a high coefficient of friction in the stow.

A.2.19 Sliding between the layers should if possible be prevented by stowing timber packages of different heights in the same layer or by inserting vertical, sturdy battens between the layers. Transverse tipping of wooden packages could be prevented by overlapping packages in successive tiers so as to create a binding stow (refer to 6.5.7).

Work safety

A.2.20 Personnel involved in the loading process should be equipped with protective clothing, i.e. hardhats, proper footwear, gloves, etc., according to ship's and harbour requirements.

A.2.21 Personnel working on cargo stowed at heights 2 m and above, within 1 m of an unguarded edge, should if deemed necessary be protected from falls with fall restraint equipment such as a safety harness or other fall restraining devices approved by the Administration.

A.2.22 While working on the cargo there should be provisions to attach a safety harness.

A.2.23 Safe access should be available to the top of, and across, the cargo stow.

A.2.24 Personnel should exercise caution when working or moving on timber packages covered by plastic wrapping or tarpaulins.

A.3 Securing of timber deck cargoes

Basic requirements on the securing

A.3.1 The stevedoring company and the crew should be informed about the requirements on the securing arrangements.

A.3.2 Uprights, when used, should be well fastened and protected from falling inwards during loading and discharging operations.

A.3.3 If required by this Code and as prescribed in the Cargo Securing Manual, uprights should be connected by hog lashings, running between each pair of uprights on opposing sides of the stow.

Repair or replacement of damaged securing equipment

A.3.4 Only undamaged cargo securing equipment should be used for securing timber deck cargo.

A.3.5 Damaged equipment that is beyond repair should be marked as unserviceable and removed from the vessel.

A.3.6 If any damage is noted on any of the uprights or their support on deck, coamings or hatches, this should immediately be repaired.

A.3.7 If any damage is noted on the fixed lashing equipment this should immediately be repaired.

A.3.8 If any damage is noted on the portable lashing equipment this should immediately be repaired or the equipment should be exchanged by new certified equipment.

Tightening of lashings

A.3.9 Threads on turnbuckles should be greased to increase pre-tension in the lashings.

A.3.10 All lashings should be thoroughly tightened and all bolts and screws on shackles and turnbuckles should be tightly fastened.

A.3.11 Turnbuckles should have sufficient threads remaining to permit lashings to be tightened during the voyage as needed.

A.3.12 Lashings should be tensioned as specified in this Code and as prescribed in the cargo securing manual.

A.3.13 Edge protectors should be used when required according to this code and as prescribed in the ship's Cargo Securing Manual to obtain good pretension in both vertical and horizontal parts of the lashings.

Provision of catwalk

A.3.14 If there is no convenient passage on or below the deck of the ship, a sturdy catwalk with strong railings should be provided above the deck cargo (refer to 2.8.6).

Securing according to the ship's Cargo Securing Manual

A.3.15 The timber deck cargo should be stowed and secured according to this code and as prescribed in the ship's Cargo Securing Manual.

A.3.16 Number and strength of uprights and lashing equipment used for the securing of the timber deck cargo should be in accordance with this code and as prescribed in the ship's Cargo Securing Manual.

A.4 Actions to be taken during the voyage

Voyage planning

A.4.1 During voyage planning, all foreseeable risks which could lead to either excessive accelerations causing cargo to shift or sloshing sea causing water absorption and ice aggregation, should be taken under consideration.

A.4.2 Before the ship proceeds to sea, the following should be verified:

- .1 The ship is upright;
- .2 The ship has an adequate metacentric height;
- .3 The ship meets the required stability criteria; and
- .4 The cargo is properly secured.

A.4.3 Soundings of tanks should be regularly carried out throughout the voyage.

A.4.4 The rolling period of the ship should be regularly checked in order to establish that the metacentric height is still within the acceptable range.

A.4.5 In cases where severe weather and sea conditions are unavoidable, the Master should be conscious of the need to reduce speed and/or alter course at an early stage in order to minimize the forces imposed on the cargo, structure and lashings.

A.4.6 If deviation from the intended voyage plan is considered during the voyage, a new plan should be made.

Cargo safety inspections during sea voyages

A.4.7 Cargo safety inspections, in accordance with the items below, should be frequently conducted throughout the voyage.

A.4.8 Prior to any inspections being commenced on deck, the Master should take appropriate actions to reduce the motions of the ship during such operations.

A.4.9 Close attention should be given to any movement of the cargo which could compromise the safety of the ship.

A.4.10 When safety permits fixed and portable lashing equipment should be visually examined for any abnormal wear and tear or other damages.

A.4.11 Since vibrations and working of the ship will cause the cargo to settle and compact, lashing equipment should be retightened to produce the necessary pre-tension, as needed.

A.4.12 Uprights should be checked for any damage or deformation.

A.4.13 Supports for upright should be undamaged.

A.4.14 Corner protections should still be in place.

A.4.15 All examinations and adjustments to cargo securing equipment during the voyage should be entered in the ship's logbook.

List during voyage

A.4.16 If a list occurs that cannot be attributed to normal use of consumables the matter should be immediately investigated. This should consider that the cause may be due to one or more of the following:

- .1 cargo shift;
- .2 water ingresses; and
- .3 an angle of loll (inadequate GM).

A.4.17 Even if no major shift of the deck cargo is apparent, it should be examined whether the deck cargo has shifted slightly or if there has been a shift of cargo below deck. However, prior to entering any closed hold that contains timber the atmosphere should be checked to make sure that the hold atmosphere has not been oxygen depleted by the timber.

A.4.18 It should be considered whether the weather conditions are such that sending the crew to release or tighten the lashings on a moving or shifted cargo present a greater hazard than retaining an overhanging load.

A.4.19 The possibility of water ingress should be determined by sounding throughout the vessel. In the event that unexplained water is detected, all available pumps, as appropriate, should be used to bring the situation under control.

A.4.20 An approximation of the current metacentric height should be determined by timing the rolling period.

A.4.21 If the list is corrected by ballasting and deballasting operations, the order in which tanks are filled and emptied should be decided with consideration to the following factors:

- .1 when the draft of the vessel increases, water ingress may occur through openings and ventilation pipes;

- .2 if ballast has been shifted to counteract a cargo shift or water ingress, a far greater list may rapidly develop to the opposite side;
- .3 if the list is due to the ship lolling, and if empty divided double bottom space is available, the tank on the lower side should be ballasted first in order to immediately provide additional metacentric height – after which the tank on the high side should also be ballasted; and
- .4 free surface moments should be kept at a minimum by operating only one tank at a time.

A.4.22 As a final resort when all other options have been exhausted if the list is to be corrected by jettisoning deck cargo, the following aspects should be noted:

- .1 jettisoning is unlikely to improve the situation entirely as the whole stack would probably not fall at once;
- .2 severe damage may be sustained by the propeller if it is still turning when the timber is jettisoned;
- .3 it will be inherently dangerous to anyone involved in the actual jettison procedure; and
- .4 the position of the jettisoning procedure and estimated navigational hazard must be immediately reported to coastal authorities.

A.4.23 If the whole or partial timber deck load is either jettisoned or accidentally lost overboard, the information on a direct danger to navigation⁽²⁶⁾ should be communicated by the master by all means at his disposal to the following parties:

- .1 ships in the vicinity; and
- .2 competent authorities at the first point on the coast with which he can communicate directly.

Such information is to include the following:

- .3 the kind of danger;
- .4 the position of the danger when last observed; and
- .5 the time and date (coordinated universal time) when the danger was last observed.

A.5 Safety during discharge of timber deck cargoes

Cargo securing equipment

A.5.1 The cargo securing equipment should be collected and examined and damaged equipment should be either repaired or scrapped.

A.5.2 Uprights, when used, should be well fastened to the deck, hatches or coamings of the vessel and protected from falling inwards during discharging operations.

Ship's safety

A.5.3 All discharge operations should be planned to immediately cease if a list develops for which there is no satisfactory explanation and it would be imprudent to continue loading.

A.5.4 The stability of the ship should, at all times, be positive and in compliance with the vessels intact stability requirements.

A.5.5 Emergency escape routes should be free and ready for use.

Work safety

A.5.6 Personnel involved in the discharge process should be dressed with protective clothing, i.e. hardhats, proper footwear, gloves, etc., according to ship's and harbour requirements.

A.5.7 While working on the cargo there should be provisions to attach a safety harness.

A.5.8 Correct signals should be agreed and used with crane operator(s).

A.5.9 Safe access should be available to the top of, and across the cargo stow.

A.5.10 All possible actions should be taken to minimize the risk of slipping on the cargo (i.e. when plastic wrapping or tarpaulins are used as covers).

A.5.11 Illumination should be used when required during the cargo operation.

ANNEX B – SAMPLES OF STOWAGE AND SECURING ARRANGEMENTS

B.1 Example calculation – Top-over lashings

In the examples below, the number of lashings required to secure packages of sawn wood on deck as well as the required racking strength in the packages in the bottom layer are calculated for a 16,600 DWT ship.

Example B.1.1 – Top-over lashings on a 16,600 DWT ship

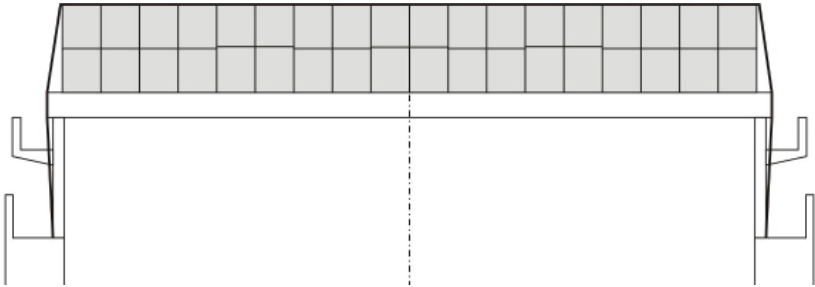

Figure B.1. Midship section of 16,600 DWT ship with packages of sawn wood in two layers secured with top-over lashings

Ship particulars

Length between perpendiculars, LPP:	134	metres
Moulded breadth, BM:	22	metres
Service speed:	14.5	knots
Metacentric height, GM:	0.70	metres

The deck cargo has the dimensions $L \times B \times H = 80 \times 19.7 \times 2.4$ metres. The total weight of the deck cargo is taken as 1,600 tons. Sliding between the layers is prevented by packages of different heights in the bottom layer.

Dimensioning transverse acceleration

With ship particulars as above and considering a stowage position on deck low, Annex 13 of the CSS Code gives a transverse acceleration of $a_t = 5.3 \text{ m/s}^2$, using the following basic acceleration and correction factors:

$$\begin{aligned}
 a_{t \text{ basic}} &= 6.5 \text{ m/s}^2 &&= \text{Basic transverse acceleration} \\
 f_{R1} &= 0.81 &&= \text{Correction factor for length and speed} \\
 f_{R2} &= 1.00 &&= \text{Correction factor for } B_M/GM
 \end{aligned}$$

$$a_t = a_{t \text{ basic}} \cdot f_{R1} \cdot f_{R2} = 6.5 \cdot 0.81 \cdot 1.00 = 5.3 \text{ m/s}^2$$

Cargo properties

m	=	1,600 ton	=	Mass of the section to be secured in tons, including absorbed water and possible icing
μ_{static}	=	0.45	=	Coefficient of static friction between the timber deck cargo and the ship's deck/hatch cover
H	=	2.4 m	=	Height of deck cargo in metres
B	=	19.7 m	=	Width of deck cargo in metres
L	=	80 m	=	Length of the deck cargo or section to be secured in metres
PW	=	192 kN	=	Wind pressure in kN based on 1 kN per m ² wind exposed area, see CSS Code, Annex 13
PS	=	160 kN	=	Pressure from unavoidable sea sloshing in kN based on 1 kN per m ² exposed area, see CSS Code, Annex 13
PT_V	=	16 kN	=	Pretension in the vertical part of the lashings in kN
α	=	85°	=	Angle between the horizontal plane and the lashings in degrees
n_p	=	18 pcs	=	Number of stacks of packages abreast in each row

Number of required top-over lashings

For pure top-over lashing arrangements with no bottom blocking, the friction alone will have to counteract the transverse forces so that the following equilibrium of forces is satisfied:

$$(m \cdot g_0 + 2 \cdot n \cdot PT_V \cdot \sin \alpha) \cdot \mu_{static} \geq m \cdot a_t + PW + PS$$

Units denoted with _a consider cargo units above the bottom layer only.

Thus the required number of top-over lashings can be calculated as:

$$n \geq \frac{m \cdot a_t + PW + PS - m \cdot g_0}{2 \cdot PT_V \cdot \sin \alpha} = \frac{1600 \cdot 5.3 + 192 + 160}{2 \cdot 16 \cdot \sin 85} - 1600 \cdot 9.81}{0.45} = 123 \text{ pcs}$$

Racking strength

To prevent the packages in the bottom layer from collapsing due to racking, the weight of the cargo stowed on top of the bottom layer should be limited so that the following equilibrium of forces is satisfied:

$$n_p \cdot L \cdot RS \geq m_a \cdot (a_t - 0.5g_0) + PW_a + PS_a$$

Units denoted with _a consider cargo units above the bottom layer only.

Thus the required racking strength can be calculated to 0.33 kN/metre:

$$RS \geq \frac{m_a \cdot (a_t - 0.5 \cdot g_0) + PW_a + PS_a}{n_p \cdot L} = \frac{800 \cdot (5.3 - 0.5 \cdot 9.81) + 96 + 64}{18 \cdot 80} = 0.33 \text{ kN/m} = 0.034 \text{ ton/m}$$

B.2 Example calculation – Bottom blocking and top-over lashings

In the example below, the required strength of the bottom blocking devices are calculated for a deck load of packages of sawn wood. The number of lashings used and the pretension of the lashings have been taken in accordance with sections 6.5.19 and 6.5.20 of this Code.

Example B.2.1 – Bottom blocking and top-over lashings on a 16,600 DWT ship

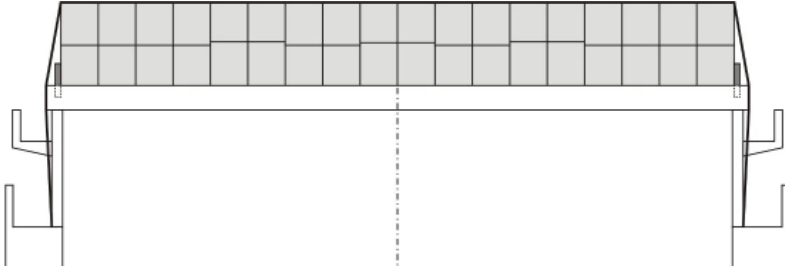

Figure B.2. Midship section of 16,600 DWT ship with packages of sawn wood in two layers secured with bottom blocking devices and top-over lashings

Ship particulars

Length between perpendiculars, LPP:	134 metres
Moulded breadth, BM:	22 metres
Service speed:	14.5 knots
Metacentric height, GM:	0.70 metres

The deck cargo has the dimensions $L \times B \times H = 80 \times 19.7 \times 2.4$ metres. The total weight of the deck cargo is taken as 1,600 tons. Sliding between the layers is prevented by packages of different heights in the bottom layer.

Dimensioning transverse acceleration

With ship particulars as above and considering a stowage position on deck low, Annex 13 of the CSS Code gives a transverse acceleration of $a_t = 5.3 \text{ m/s}^2$, using the following basic acceleration and correction factors:

$$\begin{aligned}
 a_{t \text{ basic}} &= 6.5 \text{ m/s}^2 &= \text{Basic transverse acceleration} \\
 f_{R1} &= 0.81 &= \text{Correction factor for length and speed} \\
 f_{R2} &= 1.00 &= \text{Correction factor for } B_M/GM
 \end{aligned}$$

$$a_t = a_{t \text{ basic}} \cdot f_{R1} \cdot f_{R2} = 6.5 \cdot 0.81 \cdot 1.00 = 5.3 \text{ m/s}^2$$

Cargo properties

m	=	1,600 ton	=	Mass of the section to be secured in tons, including absorbed water and possible icing
μ_{static}	=	0.45	=	Coefficient of static friction between the timber deck cargo and the ship's deck/hatch cover
H	=	2.4 m	=	Height of deck cargo in metres
B	=	19.7 m	=	Width of deck cargo in metres
L	=	80 m	=	Length of the deck cargo or section to be secured in metres
PW	=	192 kN	=	Wind pressure in kN based on 1 kN per m ² wind exposed area, see CSS Code, Annex 13
PS	=	160 kN	=	Pressure from unavoidable sea sloshing in kN based on 1 kN per m ² exposed area, see CSS Code, Annex 13
n	=	26 pcs	=	Number of top-over lashings
PT _V	=	16 kN	=	Pretension in the vertical part of the lashings in kN
α	=	85°	=	Angle between the horizontal plane and the lashings in degrees
n _p	=	18 pcs	=	Number of stacks of packages abreast in each row
n _b	=	26 pcs	=	Number of bottom blocking devices per side of the deck cargo

Required strength of the bottom blocking

The required strength, MSL, of the bottom blocking devices is given by the following equilibrium:

$$(m \cdot g_0 + 2 \cdot n \cdot PT_V \cdot \sin \alpha) \cdot \mu_{static} + n_b \frac{MSL}{1.35} \geq m \cdot a_t + PW + PS$$

$$MSL \geq \frac{1.35}{n_b} (m \cdot a_t + PW + PS - (m \cdot g_0 + 2 \cdot n \cdot PT_V \cdot \sin \alpha) \cdot \mu_{static})$$

$$MSL \geq \frac{1.35}{26} (2000 \cdot 5.3 + 192 + 160 - (2000 \cdot 9.81 + 2 \cdot 26 \cdot 16 \cdot \sin 85^\circ) \cdot 0.45) = 91kN$$

B.3 Example calculation – Loop lashings

In the example below, the required strength in loop lashings used for secure packages of sawn wood on deck is calculated.

Example B.3.1 – Loop lashings on a 16,600 DWT ship

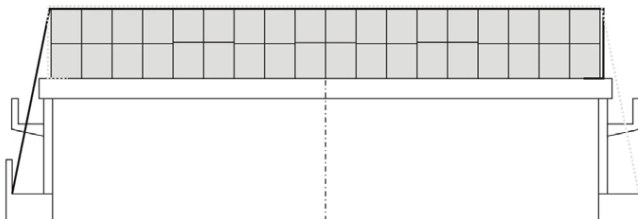

Figure B.3. Midship section of 16,600 DWT ship with packages of sawn wood secured with loop lashings

Ship particulars

Length between perpendiculars, LPP:	134 metres
Moulded breadth, BM:	22 metres
Service speed:	14.5 knots
Metacentric height, GM:	0.70 metres

The deck cargo has the dimensions $L \times B \times H = 80 \times 19.7 \times 2.4$ metres. The total weight of the deck cargo is taken as 1,600 tons. Sliding between the layers is prevented by packages of different heights in the bottom layer.

Dimensioning transverse acceleration

With vessel particulars as above and considering a stowage position on deck low, Annex 13 of the CSS Code gives a transverse acceleration of $a_t = 5.3 \text{ m/s}^2$, using the following basic acceleration and correction factors:

$a_{t \text{ basic}}$	=	6.5 m/s^2	=	Basic transverse acceleration
f_{R1}	=	0.81	=	Correction factor for length and speed
f_{R2}	=	1.00	=	Correction factor for B_M/GM

$$a_t = a_{t \text{ basic}} \cdot f_{R1} \cdot f_{R2} = 6.5 \cdot 0.81 \cdot 1.00 = 5.3 \text{ m/s}^2$$

Cargo properties

m	=	1,600 ton	=	Mass of the section to be secured in tons, including absorbed water and possible icing
$\mu_{dynamic}$	=	0.32	=	Coefficient of dynamic friction between the timber deck cargo and the ship's deck/hatch cover
H	=	2.4 m	=	Height of deck cargo in metres
B	=	19.7 m	=	Width of deck cargo in metres
L	=	80 m	=	Length of the deck cargo or section to be secured in metres
PW	=	192 kN	=	Wind pressure in kN based on 1 kN per m^2 wind exposed area, see CSS Code, Annex 13
PS	=	160 kN	=	Pressure from unavoidable sea sloshing in kN based on 1 kN per m^2 exposed area, see CSS Code, Annex 13
α	=	70°	=	Angle between the horizontal plane and the lashings in degrees
n	=	36 pcs	=	Number of loop lashings pairs
L_L	=	25 m	=	Length of each lashing in metres
PT_V	=	16 kN	=	Pretension in the vertical part of the lashings in kN
n_p	=	13 pcs	=	Number of stacks of packages abreast in each row

Number of required loop lashings

The number and strength of the lashings are to be chosen so that the following equilibrium is satisfied:

$$(m \cdot g_0 + n \cdot CS \cdot \sin \alpha) \cdot \mu_{dynamic} + n \cdot CS + n \cdot CS \cdot \cos \alpha \geq m \cdot a_t + PW + PS$$

If the number of loop lashings pairs is 36 then the required strength in the lashings can be calculated as:

$$CS \geq \frac{m \cdot (a_t - g_0 \cdot \mu_{dynamic}) + PW + PS}{n \cdot (\sin \alpha \cdot \mu_{dynamic} + 1 + \cos \alpha)} = \frac{1600 \cdot (5.3 - 9.81 \cdot 0.32) + 192 + 160}{36 \cdot (\sin 70 \cdot 0.32 + 1 + \cos 70)} = 64 \text{ kN}$$

The required MSL in the lashings is calculated as:

$$MSL = CS \cdot 1.35 = 64 \cdot 1.35 = 86 \text{ kN} = 8.8 \text{ ton}$$

Transverse movement of cargo due to elongation in lashings

The transverse movement of the deck cargo due to elongation of the lashings is calculated according to the formula below. If chains are used the elongation factor is set to $\varepsilon = 0.02$, and the transverse movement is calculated as:

$$\delta = L_L \cdot \frac{(CS - PT_V)}{MSL} \cdot \varepsilon = 25 \cdot \frac{(64 - 16)}{86} \cdot 0.02 = 0.28 \text{ m}$$

If web lashings are used the elongation factor is set to $\varepsilon = 0.07$, and the transverse movement is calculated as:

$$\delta = L_L \cdot \frac{(CS - PT_V)}{MSL} \cdot \varepsilon = 25 \cdot \frac{(64 - 16)}{86} \cdot 0.07 = 0.98 \text{ m}$$

In accordance with 6.5.16 the transverse movement of the cargo should not generate a greater heeling angle than 5 degrees. In order to comply with this requirement significantly more and/or stronger lashings than described above have to be used.

Racking strength

To prevent the packages in the bottom layer from collapsing due to racking, the weight of the cargo stowed on top of the bottom layer should be limited so that the following equilibrium of forces is satisfied:

$$n_p \cdot L \cdot RS + n \cdot CS \cdot \cos \alpha \geq m_a \cdot (a_t - 0.5g_0) + PW_a + PS_a$$

Units denoted with _a consider cargo units above the bottom layer only.

Thus the required racking strength can be calculated as:

$$RS \geq \frac{m_a \cdot (a_t - 0.5 \cdot g_0) + PW_a + PS_a - n \cdot CS \cdot \cos \alpha}{n_p \cdot L} = \frac{800 \cdot (5.3 - 0.5 \cdot 9.81) + 96 + 64 - 46 \cdot 62 \cdot \cos 70}{13 \cdot 80} < 0 \text{ kN/m}$$

There is no requirement on the racking strength of the packages, since the calculated value is less than zero.

B.4 Example Calculation – Uprights for packages of sawn wood

In the example below, the dimensioning moment for uprights supporting packages of sawn wood on deck is calculated for a 16,600 DWT ship.

Example B.4.1 – Uprights on a 16,600 DWT Vessel

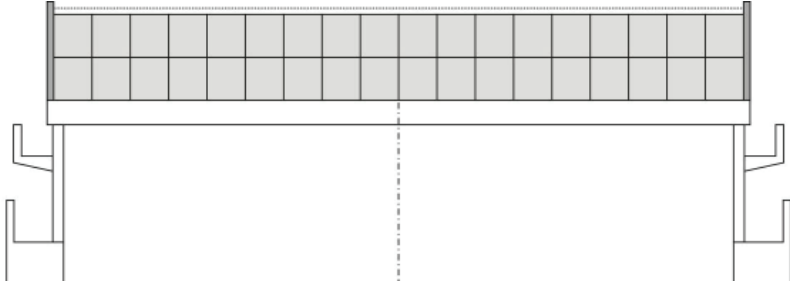

Figure B.4. Midship section of ship with timber packages secured with uprights

Ship particulars

Length between perpendiculars, LPP:	134 metres
Moulded breadth, B _M :	22 metres
Service speed:	14.5 knots
Metacentric height, GM:	0.7 metres

The deck cargo has the dimensions L × B × H = 80 × 19.7 × 2.4 metres. The total weight of the deck cargo is taken as 1,600 tons.

With ship particulars as above and considering a stowage position on deck low, Annex 13 of the CSS Code gives a transverse acceleration of $a_t = 5.3 \text{ m/s}^2$, using the following basic acceleration and correction factors:

$$\begin{aligned}
 a_{t \text{ basic}} &= 6.5 \text{ m/s}^2 &= \text{Basic transverse acceleration} \\
 f_{R1} &= 0.80 &= \text{Correction factor for length and speed} \\
 f_{R2} &= 1.00 &= \text{Correction factor for } B_M/GM
 \end{aligned}$$

$$a_t = a_{t \text{ basic}} \cdot f_{R1} \cdot f_{R2} = 6.5 \cdot 0.81 \cdot 1.00 = 5.3 \text{ m/s}^2$$

Cargo properties

m	=	1,600 ton	=	Mass of the section to be secured in tons, including absorbed water and possible icing
μ_{internal}	=	0.30	=	Coefficient of internal friction between the timber packages
H	=	2.4 m	=	Height of deck cargo in metres
b	=	1.1 m	=	Width of each individual stack of packages
n_p	=	18 pcs	=	Number of stacks of timber packages abreast in each row
q	=	2 pcs	=	Number of layers of timber packages
RS	=	3.5 kN/M	=	Racking Strength per timber package in kN/m
N	=	36 pcs	=	Number of uprights supporting the considered section on each side
H	=	2.4 m	=	Height above deck at which hoglashings are attached to the uprights in metres
K	=	1.8	=	Factor for considering hog lashings k = 1 if no hog lashings are used k = 1.8 if hog lashings are used

Bending moment in uprights

The design bending moment per upright supporting timber packages is to be taken as the greatest of the three moments given by the following formulas:

$$CM_{\text{bending1}} = \frac{m}{n_p \cdot k \cdot N} \cdot \left(a_t \cdot \frac{H}{2} - g_0 \cdot \frac{b}{2} \right) \cdot \frac{1 - (1 - f_i)^{n_p}}{f_i} \quad (\text{Moment required to prevent tipping})$$

$$\text{where } f_i = \mu_{\text{internal}} \cdot \frac{2b}{H} \quad (f_i = \text{Factor for considering internal moment})$$

$$CM_{\text{bending2}} = \frac{H}{2 \cdot k \cdot N} \cdot m \cdot (a_t - \mu_{\text{internal}} \cdot g_0) \cdot \frac{q-1}{2q} \quad (\text{Moment required to prevent sliding})$$

$$CM_{\text{bending3}} = \frac{H}{k \cdot N} \cdot (m \cdot a_t - (n_p - 4) \cdot L \cdot RS) \cdot \frac{(q-1)}{2q} \quad (\text{Moment required to prevent racking})$$

With cargo properties and acceleration as given above, the following bending moments are calculated:

$$f_i = 0.3 \cdot \frac{2 \cdot 1.1}{2.4} = 0.275$$

$$CM_{\text{bending1}} = \frac{1600}{18 \cdot 1.8 \cdot 36} \cdot \left(5.3 \cdot \frac{2.4}{2} - 9.81 \cdot \frac{1.1}{2} \right) \cdot \frac{1 - (1 - 0.275)^{18}}{0.275} = 4.8 \text{ kNm}$$

$$CM_{bending2} = \frac{2.4}{2 \cdot 1.8 \cdot 36} \cdot 1600 \cdot (5.3 - 0.30 \cdot 9.81) \cdot \frac{2-1}{2 \cdot 2} = 17.5 \text{ kNm}$$

$$CM_{bending3} = \frac{2.4}{1.8 \cdot 36} \cdot (1600 \cdot 5.3 - (18 - 4)(2 - 2) \cdot 80 \cdot 3.5) \cdot \frac{(2-1)}{2 \cdot 2} = 78.5 \text{ kNm}$$

The design bending moment, taken as the maximum bending moment calculated by the three formulae above multiplied with the safety factor of 1.35, thus becomes 106 kNm:

$$M_{bending} \geq 1.35 \cdot \max(CM_{bending1}, CM_{bending2}, CM_{bending3}) = 1.35 \cdot 78.5 = 106 \text{ kNm}$$

Suitable dimensions for uprights

With MSL taken as 50% of the MBL for steel with the ultimate strength 360 MPa (N/mm²), the required bending resistance, W, can be calculated as:

$$W = \frac{M_{bending}}{50\% \text{ of } 360 \text{ MPa}} = \frac{106 \cdot 10^6}{180} = 589 \cdot 10^3 \text{ mm}^3 = 589 \text{ cm}^3$$

Thus, uprights made from either HE220A profiles or a cylindrical profile with an outer diameter of 324 mm and a wall thickness of 10.3 mm are suitable (see section B.7).

Strength in hoglashings

The required MSL of each hog lashing is calculated by the following formula:

$$MSL \geq \frac{M_{bending}}{2 \cdot h}$$

In this case, the hoglashings are attached at a height of h = 3.5 m and the required strength is calculated as:

$$MSL \geq \frac{M_{bending}}{2 \cdot h} = \frac{106}{2 \cdot 3.5} = 15 \text{ kN} \approx 1.5 \text{ ton}$$

B.5 Example Calculation – Uprights for round wood

In the examples below, the dimensioning moments for uprights supporting round wood on deck are calculated for three different ships of varying sizes.

Example B.5.1 – Uprights for round wood on a 28,400 DWT ship

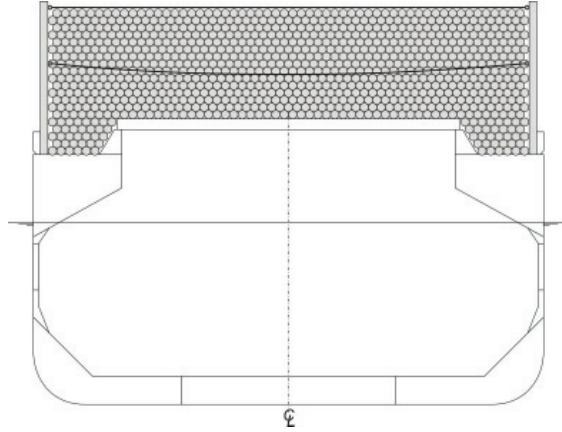

Figure B.5. Midship section of 28,400 DWT ship with round wood secured with uprights

Ship particulars

Length between perpendiculars, LPP:	160 metres
Moulded breadth, BM:	27 metres
Service speed:	14 knots
Metacentric height, GM:	0.80 metres

The deck cargo has the dimensions $L \times B \times H = 110 \times 25.6 \times 7$ metres and is supported by 42 uprights on each side. The total weight is taken as 10,500 tons.

In addition to the uprights and hog-lashings, the cargo has been secured with top-over lashings applied in accordance with sections 5.4 and 6.5.28 – 6.5.30 .

With ship particulars as above and considering a stowage position on deck low, Annex 13 of the CSS Code gives a transverse acceleration of $a_t = 4.6 \text{ m/s}^2$, using the following basic acceleration and correction factors:

$a_{t \text{ basic}}$	=	6.5 m/s^2	=	Basic transverse acceleration
f_{R1}	=	0.71	=	Correction factor for length and speed
f_{R2}	=	1.00	=	Correction factor for B_M/GM

$$a_t = a_{t \text{ basic}} \cdot k_1 \cdot k_2 = 6.5 \cdot 0.71 \cdot 1.00 = 4.6 \text{ m/s}^2$$

Cargo properties

M	=	10,500 ton	=	Mass of the section to be secured in tons, including absorbed water and possible icing
μ_{static}	=	0.35	=	Coefficient of static friction between the timber deck cargo and the ship's deck/hatch cover
H	=	7 m	=	Height of deck cargo in metres
B	=	25.6 m	=	Width of deck cargo in metres
L	=	110 m	=	Length of the deck cargo or section to be secured in metres
PW	=	770 kN	=	Wind pressure in kN based on 1 kN per m ² wind exposed area, see CSS Code, Annex 13
PS	=	220 kN	=	Pressure from unavoidable sea sloshing in kN based on 1 kN per m ² exposed area, see CSS Code, Annex 13
N	=	42 pcs	=	Number of uprights supporting the considered section on each side
h	=	3.7 / 6.7 m	=	Height above deck at which hog lashings are attached to the uprights in metres
n_{hog}	=	2 pcs	=	Number of hog lashings for each upright
k	=	1.8	=	Factor for considering hog lashings; k = 1 if no hog lashings are used k = 1.8 if hog lashings are used

Bending moment in uprights

For ships carrying loose sawn wood and round wood, the design bending moment per upright is calculated as the greater of the two moments given by the following formulas:

$$CM_{bending1} = 0.1 \cdot \frac{H^2}{k \cdot B \cdot N} \cdot m \cdot g_0$$

$$CM_{bending2} = \frac{H}{3 \cdot k \cdot N} \cdot (m \cdot (a_t - 0.6 \cdot \mu_{static} \cdot g_0) + PW + PS)$$

With cargo properties and acceleration as given above, the following bending moments are calculated:

$$CM_{bending1} = 0.1 \cdot \frac{7^2}{1.8 \cdot 25.6 \cdot 42} \cdot 10500 \cdot 9.81 = 260 \text{ kNm}$$

$$CM_{bending2} = \frac{7}{3 \cdot 1.8 \cdot 42} \cdot (10500 \cdot (4.6 - 0.6 \cdot 0.35 \cdot 9.81) + 770 + 220) = 854 \text{ kNm}$$

The design bending moment, taken as the maximum bending moment calculated by the formulae above multiplied with a safety factor of 1.35 and considering the 12% reduction allowed for by the use of properly applied top-over lashings, thus becomes:

$$M_{bending} \geq 88\% \cdot 1.35 \cdot \max(CM_{bending1}, CM_{bending2}) = 0.88 \cdot 1.35 \cdot 854 = 1015 \text{ kNm}$$

Suitable dimensions for uprights

With MSL taken as 50% of the MBL for steel with the ultimate strength 360 MPa (N/mm²), the required bending resistance, *W*, can be calculated as:

$$W = \frac{M_{bending}}{50\% \text{ of } 360MPa} = \frac{1015 \cdot 10^6}{180} = 5639 \cdot 10^3 \text{ mm}^3 = 5639 \text{ cm}^3$$

Thus, uprights made from either HE 600 B profiles or a cylindrical profile with an outer diameter of 610 mm and a wall thickness of 24.6 mm are suitable (see section B.7).

Strength in hog lashings

The required MSL of each hog lashing is calculated by the following formula:

$$MSL \geq \frac{M_{bending}}{2 \cdot h \cdot n_{hog}}$$

In this case, the hog lashings are attached at the heights 3.7 and 6.7 metres (mean height=5.2) and the required strength is calculated as:

$$MSL \geq \frac{M_{bending}}{2 \cdot h \cdot n_{hog}} = \frac{1015}{2 \cdot 5.2 \cdot 2} = 49 \text{ kN} \approx 4.9 \text{ ton}$$

Example B.5.2 – Uprights for round wood on a 16 600 DWT ship

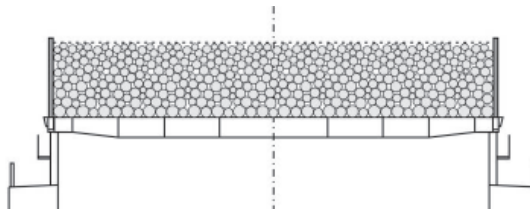

Figure B.6. Midship section of 16 600 DWT ship with round wood secured with uprights

Ship particulars

Length between perpendiculars, LPP:	134 metres
Moulded breadth, BM:	22 metres
Service speed:	14.5 knots
Metacentric height, GM:	0.70 metres

The deck cargo has the dimensions L × B × H = 80 × 19.7 × 3.7 metres and is supported by 30 uprights on each side. The weight of the cargo is taken as 3,000 tons.

With ship particulars as above and considering a stowage position on deck low, Annex 13 of the CSS Code gives a transverse acceleration of $a_t = 5.3 \text{ m/s}^2$, using the following basic acceleration and correction factors:

$$\begin{aligned} a_{t \text{ basic}} &= 6.5 \text{ m/s}^2 &= \text{Basic transverse acceleration} \\ f_{R1} &= 0.81 &= \text{Correction factor for length and speed} \\ f_{R2} &= 1.00 &= \text{Correction factor for } B_M/GM \end{aligned}$$

$$a_t = a_{t \text{ basic}} \cdot k_1 \cdot k_2 = 6.5 \cdot 0.81 \cdot 1.00 = 5.3 \text{ m/s}^2$$

Cargo properties

M	=	3,000 ton	=	Mass of the section to be secured in tons, including absorbed water and possible icing
μ_{static}	=	0.35	=	Coefficient of static friction between the timber deck cargo and the ship's deck/hatch cover
H	=	3.7 m	=	Height of deck cargo in metres
B	=	19.7 m	=	Width of deck cargo in metres
L	=	80 m	=	Length of the deck cargo or section to be secured in metres
PW	=	296 kN	=	Wind pressure in kN based on 1 kN per m ² wind exposed area, see CSS Code, Annex 13
PS	=	160 kN	=	Pressure from unavoidable sea sloshing in kN based on 1 kN per m ² exposed area, see CSS Code, Annex 13
N	=	30 pcs	=	Number of uprights supporting on each side
h	=	3.7 m	=	Height above deck at which hog lashings are attached to the uprights in metres
n_{hog}	=	1 pcs	=	Number of hog lashings for each uprights
k	=	1.8	=	Factor for considering hog lashings; k = 1 if no hog lashings are used k = 1.8 if hog lashings are used

Bending moment in uprights

For ships carrying loose sawn wood and round timber, the design bending moment per upright is calculated as the greater of the two moments given by the following formulas:

$$CM_{bending1} = 0.1 \cdot \frac{H^2}{k \cdot B \cdot N} \cdot m \cdot g_0$$

$$CM_{bending2} = \frac{H}{3 \cdot k \cdot N} \cdot (m \cdot (a_t - 0.6 \cdot \mu_{static} \cdot g_0) + PW + PS)$$

With cargo properties and acceleration as given above, the following bending moments are calculated:

$$CM_{bending1} = 0.1 \cdot \frac{3.7^2}{19.7 \cdot 30} \cdot 3000 \cdot 9.81 = 68 \text{ kNm}$$

$$CM_{bending2} = \frac{3.7}{3 \cdot 2 \cdot 30} \cdot (3000 \cdot (5.3 - 0.6 \cdot 0.35 \cdot 9.81) + 296 + 160) = 209 \text{ kNm}$$

The design bending moment, taken as the maximum bending moment calculated by the formulae above multiplied with a safety factor of 1.35, thus becomes 282 kNm:

$$M_{bending} \geq 1.35 \cdot \max(CM_{bending1}, CM_{bending2}) = 1.35 \cdot 209 = 282 \text{ kNm}$$

Suitable dimensions for uprights

With MSL taken as 50% of the MBL for steel with the ultimate strength 360 MPa (N/mm²), the required bending resistance, W, can be calculated as:

$$W = \frac{M_{bending}}{50\% \text{ of } 360 \text{ MPa}} = \frac{282 \cdot 10^6}{180} = 1568 \cdot 10^3 \text{ mm}^3 = 1568 \text{ cm}^3$$

Thus, uprights made from either HE320B profiles or a cylindrical profile with an outer diameter of 406 mm and a wall thickness of 16.7 mm are suitable (see section B.7).

Strength in hog lashings

The required MSL of each hog lashing is calculated by the following formula:

$$MSL \geq \frac{M_{bending}}{2 \cdot h \cdot n_{hog}}$$

In this case, the hog lashings are attached at a height of 3.7 metres and the required strength is calculated as:

$$MSL \geq \frac{M_{bending}}{2 \cdot h \cdot n_{hog}} = \frac{282}{2 \cdot 3.7 \cdot 1} = 38 \text{ kN} \approx 3.9 \text{ ton}$$

Example B.5.3 – Uprights for round wood on a 6,000 DWT ship on the Baltic Sea

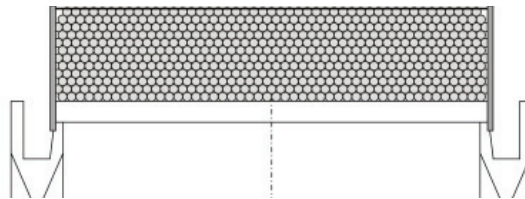

Figure B.7. Midship section of 6,000 DWT ship with round wood secured with uprights

Ship particulars

Length between perpendiculars, LPP:	101 metres
Moulded breadth, BM:	17.5 metres
Service speed:	13 knots
Metacentric height, GM:	0.50 metres

The deck cargo has the dimensions $L \times B \times H = 65 \times 14.5 \times 3.1$ metres and is supported by 25 uprights on each side. The weight of the cargo is taken as 1,500 tons.

With ship particulars as above and considering a stowage position on deck low, Annex 13 of the CSS Code gives the following basic transverse acceleration and correction factors:

$a_{t \text{ basic}}$	=	6.5	m/s^2	=	Basic transverse acceleration
f_{R1}	=	0.93		=	Correction factor for length and speed
f_{R2}	=	1.00		=	Correction factor for B_M/GM

The ship is trading in the Baltic Sea where the maximum expected significant wave height on a 20-year basis can be taken as 8.5 metres. Thus, the reduction factor for operation in restricted waters is taken as:

$$f_R = \sqrt[3]{\frac{H_M}{19.6}} = \sqrt[3]{\frac{8.5}{19.6}} = 0.76$$

$$a_t = a_{t \text{ basic}} \cdot f_{R1} \cdot f_{R2} \cdot f_R = 6.5 \cdot 0.93 \cdot 1.00 \cdot 0.76 = 4.6 \text{ m/s}^2$$

Cargo properties

M	=	1,500 ton	=	Mass of the section to be secured in tons, including absorbed water and possible icing
μ_{static}	=	0.35	=	Coefficient of static friction between the timber deck cargo and the ship's deck/hatch cover
H	=	3.1 m	=	Height of deck cargo in metres
B	=	14.5 m	=	Width of deck cargo in metres
L	=	65 m	=	Length of the deck cargo or section to be secured in metres
PW	=	202 kN	=	Wind pressure in kN based on 1 kN per m^2 wind exposed area, see CSS Code, Annex 13
PS	=	130 kN	=	Pressure from unavoidable sea sloshing in kN based on 1 kN per m^2 exposed area, see CSS Code, Annex 13
N	=	25 pcs	=	Number of uprights supporting the considered section on each side
h	=	3.1 m	=	Height above deck at which hog lashings are attached to the uprights in metres
n_{hog}	=	1 pcs	=	Number of hog lashings for each uprights
k	=	1.8	=	Factor for considering hog lashings; k = 1 if no hog lashings are used k = 1.8 if hog lashings are used

Bending moment in uprights

For ships carrying loose sawn wood and round timber, the design bending moment per upright is calculated as the greater of the two moments given by the following formulas:

$$CM_{bending1} = 0.1 \cdot \frac{H^2}{k \cdot B \cdot N} \cdot m \cdot g_0$$

$$CM_{bending2} = \frac{H}{3 \cdot k \cdot N} \cdot (m \cdot (a_t - 0.6 \cdot \mu_{static} \cdot g_0) + PW + PS)$$

With cargo properties and acceleration as given above, the following bending moments are calculated:

$$CM_{bending1} = 0.1 \cdot \frac{3.1^2}{14.5 \cdot 25} \cdot 1500 \cdot 9.81 = 39 \text{ kNm}$$

$$CM_{bending2} = \frac{3.1}{3 \cdot 1.8 \cdot 25} \cdot (1500 \cdot (4.6 - 0.6 \cdot 0.35 \cdot 9.81) + 202 + 130) = 95 \text{ kNm}$$

The design bending moment, taken as the maximum bending moment calculated by the formulae above multiplied with a safety factor of 1.35, thus becomes 128 kNm:

$$M_{bending} \geq 1.35 \cdot \max(CM_{bending1}, CM_{bending2}) = 1.35 \cdot 95 = 128 \text{ kNm}$$

Suitable dimensions for uprights

With MSL taken as 50% of the MBL for steel with the ultimate strength 360 MPa (N/mm²), the required bending resistance, W, can be calculated as:

$$W = \frac{M_{bending}}{50\% \text{ of } 360 \text{ MPa}} = \frac{128 \cdot 10^6}{180} = 713 \cdot 10^3 \text{ mm}^3 = 713 \text{ cm}^3$$

Thus, uprights made from either HE220 B profiles or a cylindrical profile with an outer diameter of 324 mm and a wall thickness of 10 mm are suitable (see section B.7).

Strength in hog lashings

The required MSL of each hog lashing is calculated by the following formula:

$$MSL \geq \frac{M_{bending}}{2 \cdot h \cdot n_{hog}}$$

In this case, the hog lashings are attached at a height of 3.7 m and the required strength is calculated as:

$$MSL \geq \frac{M_{bending}}{2 \cdot h \cdot n_{hog}} = \frac{128}{2 \cdot 3.1 \cdot 1} = 20.6 \text{ kN} \approx 2.1 \text{ ton}$$

B.6 Example calculation – frictional securing of transversely stowed round wood

Example B.6.1 – Frictional securing of round wood on a 6,000 DWT ship

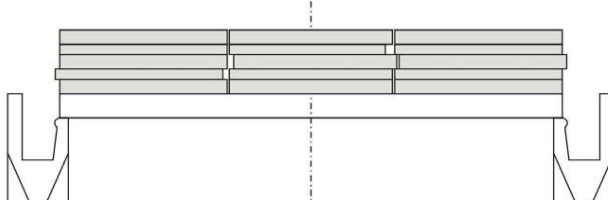

Figure B.8. Midship section of 6,000 DWT ship frictional secured wood secured

Ship particulars

Length between perpendiculars, LPP:	101 metres
Moulded breadth, BM:	17.5 metres
Service speed:	13 knots
Metacentric height, GM:	0.50 metres

The deck cargo has the dimensions $L \times B \times H = 65 \times 14.5 \times 3.1$ metres. The weight of the cargo is taken as 1,500 tons.

Cargo properties

M	=	1,500 ton	=	Mass of the section to be secured in tons, including absorbed water and possible icing
μ_{static}	=	0.35	=	Coefficient of static friction between the timber deck cargo and the ship's deck/hatch cover
H	=	3.1 m	=	Height of deck cargo in metres
B	=	14.5 m	=	Width of deck cargo in metres
L	=	65 m	=	Length of the deck cargo or section to be considered in metres
PW	=	202 kN	=	Wind pressure in kN based on 1 kN per m ² wind exposed area, see CSS Code, Annex 13
PS	=	130 kN	=	Pressure from unavoidable sea sloshing in kN based on 1 kN per m ² exposed area, see CSS Code, Annex 13

Transverse acceleration

With a static friction of 0.35 between the layers of wood and between the wood and the hatch cover the maximum acceptable transverse acceleration can be calculated by satisfying the following equilibrium:

$$m \cdot g_0 \cdot \mu_{static} \geq m \cdot a_t + PW + PS$$

In this case transverse acceleration cannot exceed 3.2 m/s^2 as shown below:

$$a_t \leq \frac{m \cdot g_0 \cdot \mu_{static} - PW - PS}{m}$$

$$a_t \leq \frac{1500 \cdot 9.81 \cdot 0.35 - 202 - 130}{1500} = 3.2 \text{ m/s}^2$$

With vessel particulars as above and considering a stowage position on deck low, Annex 13 of the CSS Code gives the following basic acceleration and correction factors:

$$\begin{aligned} a_{t \text{ basic}} &= 6.5 \text{ m/s}^2 &= \text{Basic transverse acceleration} \\ f_{R1} &= 0.93 &= \text{Correction factor for length and speed} \\ f_{R2} &= 1.00 &= \text{Correction factor for } B_M/GM \end{aligned}$$

The maximum allowed significant wave height with this stowage arrangement is calculated to 2.9 m according to the following:

$$a_t = a_{t \text{ basic}} \cdot f_{R1} \cdot f_{R2} \cdot f_R$$

$$f_R = \frac{a_t}{a_{t \text{ basic}} \cdot f_{R1} \cdot f_{R2}} = \frac{3.2}{6.5 \cdot 0.93 \cdot 1.00} = 0.53 \text{ m/s}^2$$

$$f_R = \sqrt[3]{\frac{H_M}{19.6}}$$

$$H_M = 19.6 \cdot f_R^3 = 19.6 \cdot 0.53^3 = 2.9 \text{ m}$$

B.7 Maximum bending resistance in common profiles for uprights

HE-A beams

Size	H [mm]	B [mm]	T _l [mm]	T _f [mm]	Maximum bending resistance W _x [cm ³]
HE 220 A	210	220	7	11	515
HE 240 A	230	240	7.5	12	675
HE 260 A	250	260	7.5	12.5	836
HE 280 A	270	280	8	13	1010
HE 300 A	290	300	8.5	14	1260
HE 320 A	310	300	9	15.5	1480
HE 340 A	330	300	9.5	16.5	1680
HE 360 A	350	300	10	17.5	1890
HE 400 A	390	300	11	19	2310
HE 450 A	440	300	11.5	21	2900
HE 500 A	490	300	12	23	3550
HE 550 A	540	300	12.5	24	4150
HE 600 A	590	300	13	25	4790
HE 650 A	640	300	13.5	27	5470

HE-B beams

Size	H [mm]	B [mm]	T _i [mm]	T _f [mm]	Maximum bending resistance, W _x [cm ³]
HE 220 B	210	220	9.5	16	736
HE 240 B	230	240	10	17	938
HE 260 B	250	260	10	17.5	1150
HE 280 B	270	280	10.5	18	1380
HE 300 B	290	300	11	19	1680
HE 320 B	310	300	11.5	20.5	1930
HE 340 B	330	300	12	21.5	2160
HE 360 B	350	300	12.5	22.5	2400
HE 400 B	390	300	13.5	24	2880
HE 450 B	440	300	14	26	3550
HE 500 B	490	300	14.5	28	4290
HE 550 B	540	300	15	29	4970
HE 600 B	590	300	15.5	30	5700
HE 650 B	640	300	16	31	6480

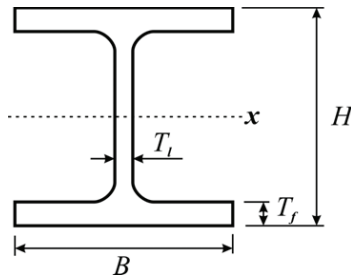

Pipes

Size	Schedule	Outer diameter [mm]	Wall thickness [mm]	Bending resistance, W [cm ³]
8"	40	219.1	8.2	276
	60	219.1	10.3	337
	80	219.1	12.7	402
12"	40	323.9	10.3	772
	60	323.9	14.3	1029
	80	323.9	17.5	1223
16"	40	406.4	12.7	1499
	60	406.4	16.7	1910
	80	406.4	21.4	2371
18"	40	457.2	14.3	2132
	60	457.2	19.1	2758
	80	457.2	23.8	3342
20"	40	508.0	15.1	2797
	60	508.0	20.6	3697
	80	508.0	26.2	4542
	100	508.0	32.5	5433
24"	40	610.0	17.5	4686
	60	610.0	24.6	6368
	80	610.0	31.0	7761

ANNEX C

INSTRUCTION TO A MASTER ON CALCULATION
OF MASS CHANGE OF A TIMBER DECK CARGO DUE TO WATER ABSORPTION

C.1 Mass increase due to water absorption for a timber deck cargo in protective packaging or covered by a protective awning or timber that has been immersed in water until loaded on board should not be taken into account in the ship's stability calculation for arrival at the port of destination.

C.2 Calculation of mass change P of a timber deck cargo should be done by the formula:

$$\delta P, \% = T_{pl} \cdot \delta P_{day}, \%$$

where:

- T_{pl} – planned duration of the voyage, days;
 $\delta P_{day}, \%$ – wood mass change per day, to be chosen from table C.1

C.3 Corresponding line in table C.1 should be chosen by means of comparison of the forthcoming voyage with the timber cargo transportation lines specified in the leftmost column "Line".

C.4 With calculation value being $\delta P \leq 2\%$, water absorption of a timber deck cargo should not be taken into account in the ship's stability calculations as it is commensurable with initial calculation data determination errors.

C.5 With calculation value being $\delta P \geq 10\%$, water absorption of a timber deck cargo $\delta P = 10\%$ should be taken into account.

Table C.1. Daily wood mass change

Line	Deck cargo mass change per day, $\delta P_{day}, \%$	
	Sawn wood	Round wood cargo
Vladivostok – ports of Japan	1.00	0.14
Ports of Malaysia – ports of Japan	0.73	0.10
Ports of Canada, USA – ports of Japan	1.00	0.14
Saint-Petersburg – London	0.83	0.11
Arkhangelsk – Manchester	1.16	0.15
Australasia – North Asia	-	-0.10

ANNEX D

REFERENCES

- (1) **SOLAS** – Chapter VI, regulation 5, paragraph 1
- (2) **ISM Code** – Part A, paragraph 1.1.2
- (3) **IMDG Code** – Part 1, chapter 1.2, paragraph 1.2.1 (Definitions)
- (4) **SOLAS** – Chapter VI, regulation 2 (Cargo information)
- (5) **ISM Code** – Part A, paragraph 7
- (6) **Load Lines, 1966** – Annex I, chapter II, regulation 16
- (7) **SOLAS** – Chapter II-1, part B-1, regulation 5-1 (Stability information)
- (8) **2008 IS Code** – Part A, section 3.3 (Cargo ships carrying timber deck cargoes)
- (9) **2008 IS Code** – Part B, section 3.6 (Stability booklet)
- (10) **2008 IS Code** – Part B, section 3.7 (Operational measures for ships carrying timber deck cargoes)
- (11) **2008 IS Code** – Part B, paragraph 3.7.5
- (12) **MEPC.127(53)** – Development of Ballast Water Management Plans
- (13) **Load Lines Convention, 1966** – Annex I, chapter IV, regulation 44 (Stowage)
- (14) **Load Lines Convention, 1966** – Annex I, chapter IV, regulation 45 (Computation for freeboard)
- (15) **SOLAS** – Chapter V, regulation 22 (Navigational bridge visibility)
- (16) **ISM Code** – Part A, paragraph 6.6
- (17) **ILO Convention No.152** – Convention Concerning Occupational Safety and Health in Dock Work
- (18) **Load Lines Convention, 1966** – Annex I, chapter II, regulation 25 (Protection of the crew)
- (19) **Load Lines Convention, 1966** – Annex I, chapter IV, regulation 44 (Stowage)
- (20) **CSS Code** – Annex 13, section 4 (Strength of securing equipment)
- (21) **ISM Code** – Part A, paragraph 7
- (22) **STCW Code** – Section A, chapter VIII/2, part 2 (Voyage planning)

- (23) **SOLAS** – Chapter V, regulation 34 (Safe navigation)
 - (24) **CSS Code** – Chapter 6 (Actions which may be taken in heavy weather)
 - (25) **MCS/Circ.1228** – Revised guidance to the master for avoiding dangerous situations in adverse weather and sea conditions
 - (26) **SOLAS** – Chapter VI, regulation 5, paragraph 2
 - (27) **MSC.1/Circ.1353** – Revised Guidelines for the preparation of the Cargo Securing Manual
 - (28) **SOLAS** – Chapter V, regulation 31 (Danger messages)
 - (29) **ILO Convention No.27** – Marking of weight (packages transported by vessels) Convention, 1929.
-

ASSEMBLY
27th session
Agenda item 9

A 27/Res.1048/Corr.1
27 January 2012
ENGLISH AND FRENCH ONLY

Resolution A.1048(27)

**Adopted on 30 November 2011
(Agenda item 9)**

**CODE OF SAFE PRACTICE FOR SHIPS CARRYING TIMBER
DECK CARGOES, 2011 (2011 TDC CODE)**

Corrigendum

CHAPTER 1 – GENERAL

1.2 Application

1 In paragraph 1.2.1, in the second sentence, the words "[to be decided]" are replaced with the words "30 November 2011".

(TSFS 2013:99)

Res. A.489(XII)

RESOLUTION A.489(XII)

Adopted on 19 November 1981
Agenda item 10(b)

**SAFE STOWAGE AND SECURING OF CARGO UNITS AND OTHER ENTITIES
IN SHIPS OTHER THAN CELLULAR CONTAINER SHIPS**

THE ASSEMBLY,

RECALLING Article 16(i) of the Convention on the Inter-Governmental Maritime Consultative Organization,

RECOGNIZING that there is a need to improve standards of stowage and securing of cargo units and other entities in ships other than cellular container ships,

RECOGNIZING ALSO that special attention should be paid to the stowage of cargo in cargo units and on vehicles,

BELIEVING that the universal application of improved standards would be greatly facilitated if all cargo units, vehicles and other entities for shipment were provided with means for applying portable securing gear,

CONSIDERING that a universal improvement in the standards could best be achieved on an international basis,

1. ADOPTS the Guidelines on the Safe Stowage and Securing of Cargo Units and Other Entities in Ships other than Cellular Container Ships, the text of which is annexed to the present resolution;
2. RECOMMENDS Governments to issue guidelines for the safe stowage and securing of cargo units and other entities in ships other than cellular container ships in conformity with the annexed Guidelines and, in particular, to require such ships entitled to fly the flag of their State to carry a Cargo Securing Manual as described in the annexed Guidelines.

ANNEX

**GUIDELINES ON THE SAFE STOWAGE AND SECURING OF CARGO UNITS
AND OTHER ENTITIES IN SHIPS OTHER THAN CELLULAR
CONTAINER SHIPS**

1 Cargo units and other entities in this context means wheeled cargo, containers, flats, pallets, portable tanks, packaged units, vehicles, etc. and parts of loading equipment which belong to the ship and which are not fixed to the ship.

2 These Guidelines apply to the securing of cargo units or other entities on open or closed decks of ships other than cellular container ships and ships specially designed and fitted for the purpose of carrying containers. Application of the Guidelines should always be at the master's discretion.

3 Applicable parts of the International Maritime Dangerous Goods Code and resolution A.288(VIII) on stowage and securing of containers on deck in ships which are not specially designed and fitted for the purpose of carrying containers should be observed.

4 Shippers' special advice or guidelines regarding handling and stowage of individual cargo units should be observed.

5 When reasonable, cargo units and other entities should be provided with means for safe application of portable securing gear. Such means should be of sufficient strength to withstand the forces which may be encountered on board ships in a seaway.

6 Cargo units and other entities should be stowed in a safe manner and secured as necessary to prevent tipping and sliding. Due regard should be paid to the forces and accelerations to which the cargo units and other entities may be subjected.

7 Ships should be provided with fixed cargo securing arrangements and with portable securing gear. Information regarding technical properties and practical application of the various items of securing equipment on board should be provided.

8 Administrations should ascertain that every ship to which these Guidelines apply is provided with a Cargo Securing Manual appropriate to the characteristics of the ship and its intended service, in particular the ship's main dimensions, its hydrostatic properties, the weather and sea conditions which may be expected in the ship's trading area and also the cargo composition.

9 Where there is reason to suspect that cargo within any unit is packed or stowed in an unsatisfactory way, or that a vehicle is in a bad state of repair, or where the unit itself cannot be safely stowed and secured on the ship, and may therefore be a source of danger to ship or crew, such unit or vehicle should not be accepted for shipment.

CARGO SECURING MANUAL

10 The information contained in the Cargo Securing Manual should include the following items as appropriate:

- .1 details of fixed securing arrangements and their locations (pad-eye, eyebolts, elephant-feet, etc.);
- .2 location and stowage of portable securing gear;
- .3 details of portable securing gear including an inventory of items provided and their strengths;
- .4 examples of correct application of portable securing gear on various cargo units, vehicles and other entities carried on the ship;
- .5 indication of the variation of transverse, longitudinal and vertical accelerations to be expected in various positions on board the ship.

RESOLUTION A.533(13)

Adopted on 17 November 1983
Agenda item 10(b)

**ELEMENTS TO BE TAKEN INTO ACCOUNT WHEN CONSIDERING THE SAFE
STOWAGE AND SECURING OF CARGO UNITS AND VEHICLES IN SHIPS**

THE ASSEMBLY,

RECALLING Article 16(j) of the Convention on the International Maritime Organization concerning the functions of the Assembly in relation to regulations concerning maritime safety,

RECALLING FURTHER that at its twelfth session it adopted resolution A.489(XII) regarding safe stowage and securing of cargo units and other entities in ships other than cellular container ships,

TAKING ACCOUNT of the IMO/ILO guidelines for training in the packing of cargo in freight containers,

RECOGNIZING that cargo units and vehicles are transported in increasing numbers on seagoing ships,

RECOGNIZING FURTHER that the cargo is stowed on and secured to cargo units and vehicles in most cases at the shipper's premises or at inland terminals and transported by road or rail to ports prior to the seagoing voyage and that the cargo on cargo units and vehicles may not always be adequately stowed or secured for safe sea transport,

REALIZING that adequately stowed and secured cargoes on cargo units and vehicles for road and rail transport in most cases would also be capable of withstanding the forces imposed on them during the sea leg of the transport,

ACKNOWLEDGING that there is a need for cargo units and vehicles presented for transport by sea to be fitted with satisfactory securing arrangements for securing them to the ship, arrangements for the securing of the cargo within the cargo unit or vehicle to facilitate its safe stowage and securing therein and for ships to be fitted with adequate securing points,

BELIEVING that the universal application of improved standards and securing arrangements is best facilitated if the elements to be taken into account when considering such matters are known to, and considered by, all links in the transport chain,

BELIEVING FURTHER that this can best be achieved on an international basis,

HAVING CONSIDERED the recommendation made by the Maritime Safety Committee at its forty-eighth session,

1. INVITES Governments to issue recommendations to the different links in the transport chain in their countries, responsible for the transport of cargo units and vehicles intended for, and including, sea transport, taking into account the elements set out in the Annex to this resolution;
2. REQUESTS the Secretary-General to bring these elements to the attention of Member Governments and international organizations responsible for the safety of road, rail and sea transport in order that they can be taken into account in the design and construction of cargo units and vehicles and the design and construction of the ships in which they are carried.

Res. A.533(13)

ANNEX

ELEMENTS TO BE TAKEN INTO ACCOUNT WHEN CONSIDERING THE SAFE STOWAGE AND SECURING OF CARGO UNITS* AND VEHICLES IN SHIPS

The elements which should be taken into account relate specifically to the safe shipment of cargo units, including vehicles. The aim is to indicate to the various parties involved the principal factors and features which need to be considered when designing and operating the ship or presenting the cargo unit, or vehicle, for such shipment. In addition, it is hoped that the elements will facilitate and promote better understanding of the problems and the needs of the masters of ships so engaged.

1 THE PARTIES INVOLVED

1.1 The elements are intended primarily for the information and guidance of the following parties which, it is considered, are in some way associated with either the design or the operation of the ship or, alternatively, with the design, presentation or loading of cargo units including vehicles. They are:

- .1 shipbuilders;
- .2 shipowners;
- .3 shipmasters;
- .4 port authorities;
- .5 shippers;
- .6 forwarding agents;
- .7 road hauliers;
- .8 stevedores;
- .9 cargo unit and vehicle manufacturers;
- .10 insurers;
- .11 railway operators; and
- .12 packers of containers at inland depots.

2 GENERAL ELEMENTS

2.1 It is of the utmost importance to ensure that:

- .1 cargo units including vehicles intended for the carriage of cargo in sea transport are in sound structural condition and have an adequate number of securing points of sufficient strength so that they can be satisfactorily secured to the ship. Vehicles should, in addition, be provided with an effective braking system; and
- .2 cargo units and vehicles are provided with an adequate number of securing points to enable the cargo to be adequately secured to the cargo unit or vehicle so as to withstand the forces, in particular the transverse forces, which may arise during the sea transport.

* Cargo units in this context means wheeled or tracked cargo, containers, flats, portable tanks, vehicles and the ship's mobile cargo handling equipment not fixed to the ship.

3 ELEMENTS TO BE CONSIDERED BY THE SHIPOWNER AND SHIPBUILDER

3.1 The ship should be provided with an adequate number of securing points of sufficient strength, a sufficient number of items of cargo securing gear of sufficient strength and a Cargo Securing Manual. In considering the number and strength of the securing points, items of cargo securing gear and the preparation of the Cargo Securing Manual, the following elements should be taken into account:

- .1 duration of the voyage;
- .2 geographical area of the voyage;
- .3 sea conditions which may be expected
- .4 size, design and characteristics of the ship;
- .5 dynamic forces under adverse weather conditions;
- .6 types of cargo units and vehicles to be carried;
- .7 intended stowage pattern of the cargo units and vehicles; and
- .8 weight of cargo units and vehicles.

3.2 The Cargo Securing Manual should provide information on the characteristics of cargo securing items and their correct application.

3.3 Ship's mobile cargo handling equipment not fixed to the ship should be provided with adequate securing points.

4 ELEMENTS TO BE CONSIDERED BY THE MASTER

4.1 When accepting cargo units or vehicles for shipment and having taken into account the elements listed in paragraph 3.1 above, the master should be satisfied that:

- .1 all decks intended for the stowage of cargo units including vehicles are in so far as is practicable free from oil and grease;
- .2 cargo units including vehicles are in an apparent good order and condition suitable for sea transport particularly with a view to their being secured;
- .3 the ship has on board an adequate supply of cargo securing gear which is maintained in sound working condition;
- .4 cargo units including vehicles are adequately stowed and secured to the ship;
and
- .5 where practicable, cargoes are adequately stowed on and secured to the cargo unit or vehicle.

4.2 In addition, cargo spaces should be regularly inspected to ensure that the cargo, cargo units and vehicles remain safely secured throughout the voyage.

5 ELEMENTS TO BE CONSIDERED BY THE SHIPPER, FORWARDING AGENTS, ROAD HAULIERS AND STEVEDORES (AND, WHERE APPROPRIATE, BY THE PORT AUTHORITIES)

5.1 Shippers or any other party involved with presenting cargo units including vehicles for shipment should appreciate that such items can be subjected to forces of great magnitude,

Res. A.533(13)

particularly in the transverse direction and especially in adverse weather conditions. Consequently, it is of importance that they should be constantly aware of this fact and that they ensure that:

- .1 cargo units including vehicles are suitable for the intended sea transport;
- .2 cargo units including vehicles are provided with adequate securing points for the securing of the cargo unit or vehicle to the ship and the cargo to the cargo unit or vehicle;
- .3 the cargo in the cargo unit or vehicle is adequately stowed and secured to withstand the forces which may arise during sea transport; and
- .4 in general the cargo unit or vehicle is clearly marked and provided with documentation to indicate its gross weight and any precautions which may have to be observed during sea transport.



E

4 ALBERT EMBANKMENT
LONDON SE1 7SR
Telephone: +44 (0)20 7735 7611 Fax: +44 (0)20 7587 3210

Ref. T1/1.02

MSC.1/Circ.1354
30 June 2010

**AMENDMENTS TO THE ELEMENTS TO BE TAKEN INTO ACCOUNT WHEN
CONSIDERING THE SAFE STOWAGE AND SECURING OF CARGO
UNITS AND VEHICLES IN SHIPS (RESOLUTION A.533(13))**

1 The Maritime Safety Committee, at its eighty-seventh session (12 to 21 May 2010), having considered the proposal by the Sub-Committee on Dangerous Goods, Solid Cargoes and Containers, at its fourteenth session (21 to 25 September 2009), approved amendments to the Elements to be taken into account when considering the safe stowage and securing of cargo units and vehicles in ships (resolution A.533(13)), set out in the annex.

2 Member Governments are invited to apply the annexed amendments to the Elements (resolution A.533(13)) and bring them to the attention of shipowners, ship operators, shipmasters and crews and all other parties concerned.

3 Member Governments are invited to bring these amendments to the attention of all parties concerned, with the aim of applying them in a consistent manner, and to implement them for containerhips, the keels of which were laid or which are at a similar stage of construction on or after 1 January 2015.

ANNEX

**AMENDMENTS TO THE ELEMENTS TO BE TAKEN INTO ACCOUNT WHEN
CONSIDERING THE SAFE STOWAGE AND SECURING OF CARGO
UNITS AND VEHICLES IN SHIPS (RESOLUTION A.533(13))**

2 General elements

1 A new subparagraph .3 is added to paragraph 2.1 as follows:

"3 safe access and safe places of work are provided for persons engaged in work connected with cargo stowage and securing."

3 Elements to be considered by the shipowner and shipbuilder

2 A new subparagraph .9 is added to paragraph 3.1 as follows:

"9 safe access, safe place of work, illumination and working conditions for persons engaged in work connected with cargo stowage and securing."

3 A new paragraph 3.4 is added as follows:

"3.4 Ships which are specifically designed and fitted for the purpose of carrying containers should be provided with a Cargo Safe Access Plan (CSAP) in order to demonstrate that personnel will have safe access for container securing operations."

4 Elements to be considered by the master

4 A new subparagraph .6 is added to paragraph 4.1 as follows:

"6 where applicable, safe access to be provided in accordance with the CSAP and maintained throughout cargo operations."

**5 Elements to be considered by the shipper, forward agents, road hauliers
and stevedores (and, where appropriate, by the port authorities)**

5 A new subparagraph .5 is added to paragraph 5.1 as follows:

"5 the CSAP, when applicable, and the lashing plan as required for by the CSM should be provided to the terminal operator in adequate time prior to the arrival of the ships."

(TSFS 2013:99)

Resolution A.864(20)
Adopted on 27 November 1997
(Agenda item 9)

RECOMMENDATIONS FOR ENTERING ENCLOSED SPACES ABOARD SHIPS

THE ASSEMBLY,

RECALLING Article 15(j) of the Convention on the International Maritime Organization concerning the functions of the Assembly in relation to regulations and guidelines concerning maritime safety,

BEING CONCERNED at the continued loss of life resulting from personnel entering shipboard spaces in which the atmosphere is oxygen-depleted, toxic or flammable,

BEING AWARE of the work undertaken in this regard by the International Labour Organization, Governments and segments of the private sector,

NOTING that the Maritime Safety Committee, at its fifty-ninth session, approved appendix F to the Code of Safe Practice for Solid Bulk Cargoes concerning recommendations for entering cargo spaces, tanks, pump-rooms, fuel tanks, cofferdams, duct keels, ballast tanks and similar enclosed spaces,

NOTING FURTHER the decision of the Maritime Safety Committee at its sixty-sixth session to replace appendix F referred to above with the recommendations annexed to this resolution,

HAVING CONSIDERED the recommendation made by the Maritime Safety Committee at its sixty-sixth session,

1. ADOPTS the Recommendations for Entering Enclosed Spaces Aboard Ships set out in the annex to the present resolution;
2. INVITES Governments to bring the annexed Recommendations to the attention of shipowners, ship operators and seafarers, urging them to apply the Recommendations, as appropriate, to all ships;
3. REQUESTS the Maritime Safety Committee to keep the Recommendations under review and amend them, as necessary.

Annex

RECOMMENDATIONS FOR ENTERING ENCLOSED SPACES ABOARD SHIPS

PREAMBLE

The object of these recommendations is to encourage the adoption of safety procedures aimed at preventing casualties to ships' personnel entering enclosed spaces where there may be an oxygen-deficient, flammable and/or toxic atmosphere.

Investigations into the circumstances of casualties that have occurred have shown that accidents on board ships are in most cases caused by an insufficient knowledge of, or disregard for, the need to take precautions rather than a lack of guidance.

Resolution A.864(20) – 189

The following practical recommendations apply to all types of ships and provide guidance to seafarers. It should be noted that on ships where entry into enclosed spaces may be infrequent, for example, on certain passenger ships or small general cargo ships, the dangers may be less apparent, and accordingly there may be a need for increased vigilance.

The recommendations are intended to complement national laws or regulations, accepted standards or particular procedures which may exist for specific trades, ships or types of shipping operations.

It may be impracticable to apply some recommendations to particular situations. In such cases, every endeavour should be made to observe the intent of the recommendations, and attention should be paid to the risks that may be involved.

1 INTRODUCTION

The atmosphere in any enclosed space may be deficient in oxygen and/or contain flammable and/or toxic gases or vapours. Such an unsafe atmosphere could also subsequently occur in a space previously found to be safe. Unsafe atmosphere may also be present in spaces adjacent to those spaces where a hazard is known to be present.

2 DEFINITIONS

2.1 *Enclosed space* means a space which has any of the following characteristics:

- .1 limited openings for entry and exit;
- .2 unfavourable natural ventilation; and
- .3 is not designed for continuous worker occupancy,

and includes, but is not limited to, cargo spaces, double bottoms, fuel tanks, ballast tanks, pump-rooms, compressor rooms, cofferdams, void spaces, duct keels, inter-barrier spaces, engine crankcases and sewage tanks.

2.2 *Competent person* means a person with sufficient theoretical knowledge and practical experience to make an informed assessment of the likelihood of a dangerous atmosphere being present or subsequently arising in the space.

2.3 *Responsible person* means a person authorized to permit entry into an enclosed space and having sufficient knowledge of the procedures to be followed.

3 ASSESSMENT OF RISK

3.1 In order to ensure safety, a competent person should always make a preliminary assessment of any potential hazards in the space to be entered, taking into account previous cargo carried, ventilation of the space, coating of the space and other relevant factors. The competent person's preliminary assessment should determine the potential for the presence of an oxygen-deficient, flammable or toxic atmosphere.

3.2 The procedures to be followed for testing the atmosphere in the space and for entry should be decided on the basis of the preliminary assessment. These will depend on whether the preliminary assessment shows that:

- .1 there is minimal risk to the health or life of personnel entering the space;
- .2 there is no immediate risk to health or life but a risk could arise during the course of work in the space; and
- .3 a risk to health or life is identified.

3.3 Where the preliminary assessment indicates minimal risk to health or life or potential for a risk to arise during the course of work in the space, the precautions described in 4, 5, 6 and 7 should be followed as appropriate.

3.4 Where the preliminary assessment identifies risk to life or health, if entry is to be made, the additional precautions specified in section 8 should also be followed.

4 AUTHORIZATION OF ENTRY

4.1 No person should open or enter an enclosed space unless authorized by the master or nominated responsible person and unless the appropriate safety procedures laid down for the particular ship have been followed.

4.2 Entry into enclosed spaces should be planned and the use of an entry permit system, which may include the use of a checklist, is recommended. An Enclosed Space Entry Permit should be issued by the master or nominated responsible person, and completed by a person who enters the space prior to entry. An example of the Enclosed Space Entry Permit is provided in the appendix.

5 GENERAL PRECAUTIONS

5.1 The master or responsible person should determine that it is safe to enter an enclosed space by ensuring:

- .1** that potential hazards have been identified in the assessment and as far as possible isolated or made safe;
- .2** that the space has been thoroughly ventilated by natural or mechanical means to remove any toxic or flammable gases, and to ensure an adequate level of oxygen throughout the space;
- .3** that the atmosphere of the space has been tested as appropriate with properly calibrated instruments to ascertain acceptable levels of oxygen and acceptable levels of flammable or toxic vapours;
- .4** that the space has been secured for entry and properly illuminated;
- .5** that a suitable system of communication between all parties for use during entry has been agreed and tested;
- .6** that an attendant has been instructed to remain at the entrance to the space whilst it is occupied;
- .7** that rescue and resuscitation equipment has been positioned ready for use at the entrance to the space, and that rescue arrangements have been agreed;
- .8** that personnel are properly clothed and equipped for the entry and subsequent tasks; and
- .9** that a permit has been issued authorizing entry.

The precautions in .6 and .7 may not apply to every situation described in this section. The person authorizing entry should determine whether an attendant and the positioning of rescue equipment at the entrance to the space is necessary.

5.2 Only trained personnel should be assigned the duties of entering, functioning as attendants, or functioning as members of rescue teams. Ships' crews should be drilled periodically in rescue and first aid.

5.3 All equipment used in connection with entry should be in good working condition and inspected prior to use.

6 TESTING THE ATMOSPHERE

6.1 Appropriate testing of the atmosphere of a space should be carried out with properly calibrated equipment by persons trained in the use of the equipment. The manufacturers' instructions should be strictly followed. Testing should be carried out before any person enters the space, and at regular intervals thereafter until all work is completed. Where appropriate, the testing of the space should be carried out at as many different levels as is necessary to obtain a representative sample of the atmosphere in the space.

6.2 For entry purposes, steady readings of the following should be obtained:

- .1 21% oxygen by volume by oxygen content meter; and
- .2 not more than 1% of lower flammable limit (LFL) on a suitably sensitive combustible gas indicator, where the preliminary assessment has determined that there is potential for flammable gases or vapours.

If these conditions cannot be met, additional ventilation should be applied to the space and re-testing should be conducted after a suitable interval. Any gas testing should be carried out with ventilation to the enclosed space stopped, in order to obtain accurate readings.

6.3 Where the preliminary assessment has determined that there is potential for the presence of toxic gases and vapours, appropriate testing should be carried out using fixed or portable gas- or vapour-detection equipment. The readings obtained by this equipment should be below the occupational exposure limits for the toxic gases or vapours given in accepted national or international standards. It should be noted that testing for flammability does not provide a suitable means of measuring for toxicity, nor vice versa.

6.4 It should be emphasized that pockets of gas or oxygen-deficient areas can exist, and should always be suspected, even when an enclosed space has been satisfactorily tested as being suitable for entry.

7 PRECAUTIONS DURING ENTRY

7.1 The atmosphere should be tested frequently whilst the space is occupied, and persons should be instructed to leave the space should there be a deterioration in the conditions.

7.2 Ventilation should continue during the period that the space is occupied and during temporary breaks. Before re-entry after a break, the atmosphere should be re-tested. In the event of failure of the ventilation system, any persons in the space should leave immediately.

7.3 In the event of an emergency, under no circumstances should the attending crew member enter the space before help has arrived and the situation has been evaluated to ensure the safety of those entering the space to undertake rescue operations.

8 ADDITIONAL PRECAUTIONS FOR ENTRY INTO A SPACE WHERE THE ATMOSPHERE IS KNOWN OR SUSPECTED TO BE UNSAFE

8.1 If the atmosphere in an enclosed space is suspected or known to be unsafe, the space should only be entered when no practical alternative exists. Entry should only be made for further testing, essential operation, safety of life or safety of a ship. The number of persons entering the space should be the minimum compatible with the work to be performed.

8.2 Suitable breathing apparatus, e.g. of the air-line or self-contained type, should always be worn, and only personnel trained in its use should be allowed to enter the space. Air-purifying respirators should not be used as they do not provide a supply of clean air from a source independent of the atmosphere within the space.

8.3 The precautions specified in 5 should also be followed, as appropriate.

8.4 Rescue harnesses should be worn and, unless impractical, lifelines should be used.

8.5 Appropriate protective clothing should be worn particularly where there is any risk of toxic substances or chemicals coming into contact with the skin or eyes of those entering the space.

8.6 The advice in 7.3 concerning emergency rescue operations is particularly relevant in this context.

9 HAZARDS RELATED TO SPECIFIC TYPES OF CARGO

9.1 Dangerous goods in packaged form

9.1.1 The atmosphere of any space containing dangerous goods may put at risk the health or life of any person entering it. Dangers may include flammable, toxic or corrosive gases or vapours that displace oxygen, residues on packages and spilled material. The same hazards may be present in spaces adjacent to the cargo spaces. Information on the hazards of specific substances is contained in the IMDG Code, the Emergency Procedures for Ships Carrying Dangerous Goods (EmS) and Materials Safety Data Sheets (MSDS). If there is evidence or suspicion that leakage of dangerous substances has occurred, the precautions specified in 8 should be followed.

9.1.2 Personnel required to deal with spillages or to remove defective or damaged packages should be appropriately trained and wear suitable breathing apparatus and appropriate protective clothing.

9.2 Bulk liquid

The tanker industry has produced extensive advice to operators and crews of ships engaged in the bulk carriage of oil, chemicals and liquefied gases, in the form of specialist international safety guides. Information in the guides on enclosed space entry amplifies these recommendations and should be used as the basis for preparing entry plans.

9.3 Solid bulk

On ships carrying solid bulk cargoes, dangerous atmospheres may develop in cargo spaces and adjacent spaces. The dangers may include flammability, toxicity, oxygen depletion or self-heating, which should be identified in shipping documentation. For additional information, reference should be made to the Code of Safe Practice for Solid Bulk Cargoes.

9.4 Oxygen-depleting cargoes and materials

A prominent risk with such cargoes is oxygen depletion due to the inherent form of the cargo, for example, self-heating, oxidation of metals and ores or decomposition of vegetable oils, animal fats, grain and other organic materials or their residues. The materials listed below are known to be capable of causing oxygen depletion. However, the list is not exhaustive. Oxygen depletion may also be caused by other materials of vegetable or animal origin, by flammable or spontaneously combustible materials, and by materials with a high metal content:

- .1** grain, grain products and residues from grain processing (such as bran, crushed grain, crushed malt or meal), hops, malt husks and spent malt;
- .2** oilseeds as well as products and residues from oilseeds (such as seed expellers, seed cake, oil cake and meal);
- .3** copra;
- .4** wood in such forms as packaged timber, roundwood, logs, pulpwood, props (pit props and other propwood), woodchips, woodshavings, woodpulp pellets and sawdust;
- .5** jute, hemp, flax, sisal, kapok, cotton and other vegetable fibres (such as esparto grass/Spanish grass, hay, straw, bhusa), empty bags, cotton waste, animal fibres, animal and vegetable fabric, wool waste and rags;

- .6 fishmeal and fishscrap;
- .7 guano;
- .8 sulphidic ores and ore concentrates;
- .9 charcoal, coal and coal products;
- .10 direct reduced iron (DRI)
- .11 dry ice;
- .12 metal wastes and chips, iron swarf, steel and other turnings, borings, drillings, shavings, filings and cuttings; and
- .13 scrap metal.

9.5 Fumigation

When a ship is fumigated, the detailed recommendations contained in the Recommendations on the safe use of pesticides in ships* should be followed. Spaces adjacent to fumigated spaces should be treated as if fumigated.

10 CONCLUSION

Failure to observe simple procedures can lead to people being unexpectedly overcome when entering enclosed spaces. Observance of the principles outlined above will form a reliable basis for assessing risks in such spaces and for taking necessary precautions.

* Refer to the Recommendations on safe use of pesticides in ships, approved by the Maritime Safety Committee of the Organization by circular MSC/Circ.612, as amended by MSC/Circ.689 and MSC/Circ.746.

Appendix

Example of an Enclosed Space Entry Permit

This permit relates to entry into any enclosed space and should be completed by the master or responsible officer and by the person entering the space or authorized team leader.

General			
Location/name of enclosed space.....			
Reason for entry.....			
This permit is valid	from:	hrs	Date
	to:	hrs	Date
(See note 1)			

Section 1 – Pre-entry preparation			
(To be checked by the master or nominated responsible person)			
	Yes	No	
● Has the space been thoroughly ventilated?	<input type="checkbox"/>	<input type="checkbox"/>	
● Has the space been segregated by blanking off or isolating all connecting pipelines or valves and electrical power/equipment?	<input type="checkbox"/>	<input type="checkbox"/>	
● Has the space been cleaned where necessary?	<input type="checkbox"/>	<input type="checkbox"/>	
● Has the space been tested and found safe for entry? (See note 2)	<input type="checkbox"/>	<input type="checkbox"/>	
● Pre-entry atmosphere test readings:			
– oxygen	% vol (21%)	By:	
– hydrocarbon	% LFL (less than 1%)	Time:	
– toxic gases	ppm (specific gas and PEL)	(See note 3)	
● Have arrangements been made for frequent atmosphere checks to be made while the space is occupied and after work breaks?	<input type="checkbox"/>	<input type="checkbox"/>	
● Have arrangements been made for the space to be continuously ventilated throughout the period of occupation and during work breaks?	<input type="checkbox"/>	<input type="checkbox"/>	
● Are access and illumination adequate?	<input type="checkbox"/>	<input type="checkbox"/>	

	Yes	No
● Is rescue and resuscitation equipment available for immediate use by the entrance to the space?	<input type="checkbox"/>	<input type="checkbox"/>
● Has a responsible person been designated to be in constant attendance at the entrance to the space?	<input type="checkbox"/>	<input type="checkbox"/>
● Has the officer of the watch (bridge, engine-room, cargo control room) been advised of the planned entry?	<input type="checkbox"/>	<input type="checkbox"/>
● Has a system of communication between all parties been tested and emergency signals agreed?	<input type="checkbox"/>	<input type="checkbox"/>
● Are emergency and evacuation procedures established and understood by all personnel involved with the enclosed space entry?	<input type="checkbox"/>	<input type="checkbox"/>
● Is all equipment used in good working condition and inspected prior to entry?	<input type="checkbox"/>	<input type="checkbox"/>
● Are personnel properly clothed and equipped?	<input type="checkbox"/>	<input type="checkbox"/>

Section 2 – Pre-entry checks		
(To be checked by the person entering the space or authorized team leader)	Yes	No
● I have received instructions or permission from the master or nominated responsible person to enter the enclosed space	<input type="checkbox"/>	<input type="checkbox"/>
● Section 1 of this permit has been satisfactorily completed by the master or nominated responsible person	<input type="checkbox"/>	<input type="checkbox"/>
● I have agreed and understand the communication procedures	<input type="checkbox"/>	<input type="checkbox"/>
● I have agreed upon a reporting interval of.....minutes	<input type="checkbox"/>	<input type="checkbox"/>
● Emergency and evacuation procedures have been agreed and are understood	<input type="checkbox"/>	<input type="checkbox"/>
● I am aware that the space must be vacated immediately in the event of ventilation failure or if atmosphere tests show a change from agreed safe criteria	<input type="checkbox"/>	<input type="checkbox"/>

Section 3 – Breathing apparatus and other equipment

(To be checked jointly by the master or nominated responsible person and the person who is to enter the space)

	Yes	No
● Those entering the space are familiar with the breathing apparatus to be used	<input type="checkbox"/>	<input type="checkbox"/>
● The breathing apparatus has been tested as follows:		
- gauge and capacity of air supply
- low pressure audible alarm
- face mask - under positive pressure and not leaking
● The means of communication has been tested and emergency signals agreed	<input type="checkbox"/>	<input type="checkbox"/>
● All personnel entering the space have been provided with rescue harnesses and, where practicable, lifelines	<input type="checkbox"/>	<input type="checkbox"/>

Signed upon completion of sections 1,2 and 3 by:

Master or nominated responsible person..... Date..... Time.....

Responsible person supervising entry..... Date..... Time.....

Person entering the space or authorized team leader..... Date..... Time.....

Section 4 – Personnel entry

(To be completed by the responsible person supervising entry)

Names	Time in	Time out
.....
.....
.....
.....

Section 5 – Completion of job

(To be completed by the responsible person supervising entry)

- Job completed Date..... Time.....
- Space secured against entry Date..... Time.....
- The officer of the watch has been duly informed Date..... Time.....

Signed upon completion of sections 4 and 5 by:

Responsible person supervising entry..... Date..... Time.....

THIS PERMIT IS RENDERED INVALID SHOULD VENTILATION OF THE SPACE STOP OR IF ANY OF THE CONDITIONS NOTED IN THE CHECKLIST CHANGE

Notes:

- 1 The permit should contain a clear indication as to its maximum period of validity.
- 2 In order to obtain a representative cross-section of the space's atmosphere, samples should be taken from several levels and through as many openings as possible. Ventilation should be stopped for about 10 minutes before the pre-entry atmosphere tests are taken.
- 3 Tests for specific toxic contaminants, such as benzene or hydrogen sulphide, should be undertaken depending on the nature of the previous contents of the space.

STOP!

Have you been through the drill?

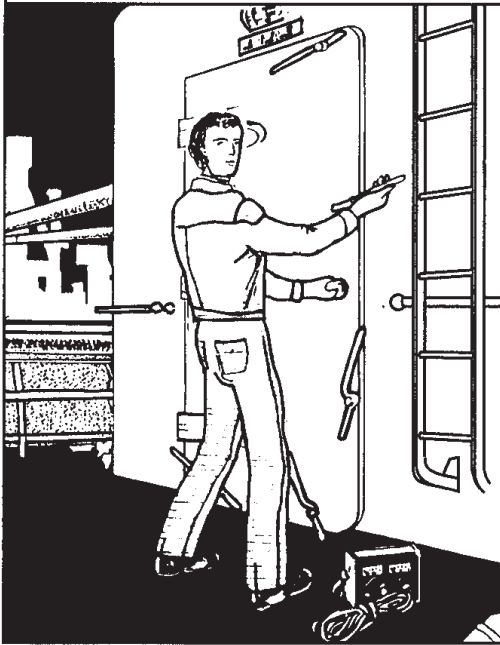

You should
NEVER enter
any enclosed
space unless
an Enclosed
Space Entry
Permit has
been issued

Enclosed spaces can kill!

Do not ignore or forget it –

you may end up like this



Res. A.581(14)

RESOLUTION A.581(14)

Adopted on 20 November 1985
Agenda item 10(b)

**GUIDELINES FOR SECURING ARRANGEMENTS FOR THE
TRANSPORT OF ROAD VEHICLES ON RO-RO SHIPS**

THE ASSEMBLY,

RECALLING Article 15(j) of the Convention on the International Maritime Organization concerning the functions of the Assembly in relation to regulations and guidelines concerning maritime safety,

RECALLING ALSO resolution A.489(XII) on safe stowage and securing of cargo units and other entities in ships other than cellular containerhips and MSC/Circ. 385 of 8 January 1985 containing the provisions to be included in a cargo securing manual to be carried on board ships,

BEARING IN MIND resolution A.533(I3) on elements to be taken into account when considering the safe stowage and securing of cargo units and vehicles in ships,

TAKING ACCOUNT of the revised IMO/ILO Guidelines for the Packing of Cargo in Freight Containers and Vehicles,

RECOGNIZING that the marine transport of road vehicles on ro-ro ships is increasing,

RECOGNIZING ALSO that a number of serious accidents have occurred because of inadequate securing arrangements on ships and road vehicles,

RECOGNIZING FURTHER the need for the Organization to establish guidelines for securing arrangements on board ro-ro ships and on road vehicles,

REALIZING that given adequately designed ships and properly equipped road vehicles, lashings of sufficient strength will be capable of withstanding the forces imposed on them during the voyage,

REALIZING FURTHER that certain requirements for side guards, particularly those positioned very low on road vehicles, will obstruct the proper securing of the road vehicles on board ro-ro ships and that appropriate measures will have to be taken to satisfy both safety aspects,

BELIEVING that application of the guidelines will enhance safety in the transport of road vehicles on ro-ro ships and that this can be achieved on an international basis,

HAVING CONSIDERED the recommendation made by the Maritime Safety Committee at its fifty-first session,

1. ADOPTS the Guidelines for Securing Arrangements for the Transport of Road Vehicles on Ro-ro Ships set out in the Annex to the present resolution;
2. URGES Member Governments to implement these Guidelines at the earliest possible opportunity in respect of new ro-ro ships and new vehicles and, as far as practicable, in respect of existing vehicles which may be transported on ro-ro ships;

Res. A.581(14)

3. REQUESTS the Secretary-General to bring these Guidelines to the attention of Member Governments and relevant international organizations responsible for safety in design and construction of ships and road vehicles for action as appropriate.

ANNEX

GUIDELINES FOR SECURING ARRANGEMENTS FOR THE TRANSPORT OF ROAD VEHICLES ON RO-RO SHIPS

PREAMBLE

In view of experience in the transport of road vehicles on ro-ro ships, it is recommended that these Guidelines for securing road vehicles on board such ships should be followed. Shipowners and shipyards, when designing and building ro-ro ships to which these Guidelines apply, should take sections 4 and 6 particularly into account. Manufacturers, owners and operators of road vehicles which may be transported on ro-ro ships should take sections 5 and 7 particularly into account.

1 SCOPE

1.1 These Guidelines for securing and lashing road vehicles on board ro-ro ships outline in particular the securing arrangements on the ship and on the vehicles, and the securing methods to be used.

2 APPLICATION

2.1 These Guidelines apply to ro-ro ships which regularly carry road vehicles on either long or short international voyages in unsheltered waters. They concern:

- .1 road vehicles as defined in 3.2.1, 3.2.2, 3.2.3 and 3.2.5 with an authorized maximum total mass of vehicles and cargo of between 3.5 and 40 tonnes; and
- .2 articulated road trains as defined in 3.2.4 with a maximum total mass of not more than 45 tonnes, which can be carried on ro-ro ships.

2.2 These Guidelines do not apply to buses.

2.3 For road vehicles having characteristics outside the general parameters for road vehicles (particularly where the normal height of the centre of gravity is exceeded), the location and the number of securing points should be specially considered.

3 DEFINITIONS

3.1 *“Ro-ro ship”* means a ship which has one or more decks either closed or open, not normally subdivided in any way and generally running the entire length of the ship, in which goods (packaged or in bulk, in or on road vehicles (including road tank-vehicles), trailers, containers, pallets, demountable or portable tanks or in or on similar cargo transport units or other receptacles) can be loaded or unloaded normally in a horizontal direction.

Res. A.581(14)

3.2 In these Guidelines the term road vehicle¹ includes:

- .1 **Commercial vehicle** which means a motor vehicle which, on account of its design and appointments, is used mainly for conveying goods. It may also be towing a trailer.
- .2 **Semi-trailer** which means a trailer which is designed to be coupled to a semi-trailer towing vehicle and to impose a substantial part of its total mass on the towing vehicle.
- .3 **Road train** which means the combination of a motor vehicle with one or more independent trailers connected by a draw-bar. (For the purpose of section 5 each element of a road train is considered a separate vehicle.)
- .4 **Articulated road train** which means the combination of a semi-trailer towing vehicle with a semi-trailer.
- .5 **Combination of vehicles** which means a motor vehicle coupled with one or more towed vehicles. (For the purpose of section 5 each element of a combination of vehicles is considered a separate vehicle.)

4 SECURING POINTS ON SHIPS' DECKS

4.1 The ship should carry a Cargo Securing Manual in accordance with resolution A.489(XII) containing the information listed and recommended in paragraph 10 of the Annex to that resolution.

4.2 The decks of a ship intended for road vehicles as defined in 3.2 should be provided with securing points. The arrangement of securing points should be left to the discretion of the shipowner provided that for each road vehicle or element of a combination of road vehicles, there is the following minimum arrangement of securing points:

- .1 The distance between securing points in the longitudinal direction should in general not exceed 2.5 m. However, there may be a need for the securing points in the forward and after parts of the ship to be more closely spaced than they are amidships.
- .2 The thwartships spacing of securing points should not be less than 2.8 m nor more than 3 m. However, there may be a need for the securing points in the forward and after parts of the ship to be more closely spaced than they are amidships.
- .3 The minimum strength without permanent deformation of each securing point should be 120 kN. If the securing point is designed to accommodate more than one lashing (γ lashings) the corresponding strength should be not less than $\gamma \times 120$ kN.

4.3 In ro-ro ships which only occasionally carry road vehicles, the spacing and strength of securing points should be such that the special considerations which may be necessary to stow and secure road vehicles safely are taken into account.

5 SECURING POINTS ON ROAD VEHICLES

5.1 Securing points on road vehicles should be designed for securing the road vehicles to the ship and should have an aperture capable of accepting only one lashing. The securing

¹ Reference is made to ISO Standard No. 3833 (under revision).

Res. A.581(14)

point and aperture should permit varying directions of the lashing to the ship's deck¹.

5.2 The same number of not less than two or more than six securing points should be provided on each side of the road vehicle in accordance with the provisions of 5.3.

5.3 Subject to the provisions of notes 1, 2 and 3 hereunder, the minimum number and minimum strength of securing points should be in accordance with the following table:

Gross vehicle mass (GVM) tonnes	Minimum number of securing points on each side of the road vehicle	Minimum strength without permanent deformation of each securing point as fitted (kN)
3.5 t ≤ GVM ≤ 20 t	2	$\frac{GVM \times 10 \times 1.2}{n^*}$
20 t < GVM ≤ 30 t	3	
30 t < GVM ≤ 40 t	4	

* Where n is the total number of securing points on each side of the road vehicle.

Note 1: For road trains, the table applies to each component, i.e. to the motor vehicle and each trailer, respectively.

Note 2: Semi-trailer towing vehicles are excluded from the table above. They should be provided with two securing points at the front of the vehicle, the strength of which should be sufficient to prevent lateral movement of the front of the vehicle. A towing coupling at the front may replace the two securing points.

Note 3: If the towing coupling is used for securing vehicles other than semi-trailer towing vehicles, this should not replace or be substituted for the above-mentioned minimum number and strength of securing points on each side of the vehicle.

5.4 Each securing point on the vehicle should be marked in a clearly visible colour.

5.5 Securing points on vehicles should be so located as to ensure effective restraint of the vehicle by the lashings.

5.6 Securing points should be capable of transferring the forces from the lashings to the chassis of the road vehicle and should never be fitted to bumpers or axles unless these are specially constructed and the forces are transmitted directly to the chassis.

5.7 Securing points should be so located that lashings can be readily and safely attached, particularly where side-guards are fitted to the vehicle.

5.8 The internal free passage of each securing point's aperture should be not less than 80 mm but the aperture need not be circular in shape.

5.9 Equivalent or superior securing arrangements may be considered for vehicles for which the provisions of table 5.3 are unsuitable.

¹ If more than one aperture is provided at a securing point, each aperture should have the strength for the securing point in the table in 5.3.

Res. A.581(14)

6 LASHINGS

6.1 Lashings should consist of chain or any other device and be made of material having strength and elongation characteristics at least equivalent to those of steel chain. The strength of the lashings, without permanent deformation, should be not less than 120 kN.

6.2 Lashings should be so designed and attached that, provided there is safe access, it is possible to tighten them if they become slack. Where practicable and necessary, the lashings should be examined at regular intervals during the voyage and tightened as necessary.

6.3 Lashings should be attached to the securing points with hooks or other devices so designed that they cannot disengage from the aperture of the securing point if the lashing slackens during the voyage.

6.4 Only one lashing should be attached to any one aperture of the securing point on the vehicle.

6.5 Lashings should only be attached to the securing points provided for that purpose.

6.6 Lashings should be attached to the securing points on the vehicle in such a way that the angle between the lashing and the horizontal and vertical planes lies preferably between 30° and 60°.

6.7 Bearing in mind the characteristics of the ship and the weather conditions expected on the intended voyage, the master should decide on the number of securing points and lashings to be used for each voyage.

6.8 Where there is doubt that a road vehicle complies with the provisions of table 5.3, the master may, at his discretion, load the vehicle on board, taking into account the apparent condition of the vehicle, the weather and sea conditions expected on the intended voyage and all other circumstances.

7 STOWAGE

7.1 Depending on the area of operation, the predominant weather conditions and the characteristics of the ship, road vehicles should be stowed so that the chassis are kept as static as possible by not allowing free play in the suspension of the vehicles. This can be done, for example, by compressing the springs by tightly securing the vehicle to the deck, by jacking up the chassis prior to securing the vehicle or by releasing the air pressure on compressed air suspension systems.

7.2 Taking into account the conditions referred to in 7.1 and the fact that compressed air suspension systems may loose air, the air pressure should be released on every vehicle fitted with such a system if the voyage is of more than 24 hours duration. If practicable, the air pressure should be released also on voyages of a shorter duration. If the air pressure is not released, the vehicle should be jacked up to prevent any slackening of the lashings resulting from any air leakage from the system during the voyage.

7.3 Where jacks are used on a vehicle, the chassis should be strengthened in way of the jacking-up points and the position of the jacking-up points should be clearly marked.

7.4 Special consideration should be given to the securing of road vehicles stowed in positions where they may be exposed to additional forces. Where vehicles are stowed athwartship, special consideration should be given to the forces which may arise from such stowage.

7.5 Wheels should be chocked to provide additional security in adverse conditions.

Res. A.581(14)

7.6 Vehicles with diesel engines should not be left in gear during the voyage.

7.7 Vehicles designed to transport loads likely to have an adverse effect on their stability, such as hanging meat, should have integrated in their design a means of neutralizing the suspension system.

7.8 Stowage should be arranged in accordance with the following:

- .1 The parking brakes of each vehicle or of each element of a combination of vehicles should be applied and locked.
- .2 Semi-trailers, by the nature of their design, should not be supported on their landing legs during sea transport unless the landing legs are specially designed for that purpose and so marked. An uncoupled semi-trailer should be supported by a trestle or similar device placed in the immediate area of the drawplate so that the connection of the fifth-wheel to the kingpin is not restricted. Semi-trailer designers should consider the space and the reinforcements required and the selected areas should be clearly marked.

INTERNATIONAL MARITIME ORGANIZATION

4 ALBERT EMBANKMENT
LONDON SE1 7SR

Telephone: 0171-735 7611
Fax: 0171-587 3210
Telex: 23588 IMOLDN G



MSC/Circ.812
16 June 1997

Ref. T3/2.01

**AMENDMENTS TO THE GUIDELINES FOR SECURING ARRANGEMENTS FOR THE
TRANSPORT OF ROAD VEHICLES ON RO-RO SHIPS (RESOLUTION A.581(14))
AND THE CODE OF SAFE PRACTICE FOR CARGO STOWAGE
AND SECURING (RESOLUTION A.714(17))**

1 The Maritime Safety Committee, at its sixty-eighth session (28 May to 6 June 1997), having considered draft amendments to the Guidelines for securing arrangements for the transport of road vehicles on ro-ro ships (resolution A.581(14)) and the Code of Safe Practice for Cargo Stowage and Securing (resolution A.714(17)), prepared by the Sub-Committee on Dangerous Goods, Solid Cargoes and Containers, at its second session, approved the proposed amendments set out in the annex.

2 These amendments aim at extending the provisions of the Guidelines for securing arrangements for transport of road vehicles on ro-ro ships, to cover the use of web lashings which are widely accepted on such ships.

3 Member Governments are invited to bring the attached amendments to the attention of all parties concerned with a view to implementing them as soon as possible.

ANNEX

**AMENDMENTS TO THE GUIDELINES FOR SECURING ARRANGEMENTS FOR THE
TRANSPORT OF ROAD VEHICLES ON RO-RO SHIPS (RESOLUTION A.581(14))
AND TO THE CODE OF SAFE PRACTICE FOR CARGO STOWAGE
AND SECURING (RESOLUTION A.714(17))**

**GUIDELINES FOR SECURING ARRANGEMENTS FOR THE TRANSPORT
OF ROAD VEHICLES ON RO-RO SHIPS (RESOLUTION A.581(14))**

- 1 The existing text of paragraph 4.2.3 is replaced by the following:

"The maximum securing load (MSL) of each securing point should be not less than 100 kN. If the securing point is designed to accommodate more than one lashing (y lashings), the MSL should be not less than $y \times 100$ kN".

- 2 The existing text of paragraph 6.1 is replaced by the following:

"The maximum securing load (MSL) of lashings should not be less than 100 kN, and they should be made of material having suitable elongation characteristics."

**CODE OF SAFE PRACTICE FOR CARGO STOWAGE AND SECURING
(RESOLUTION A.714(17))**

Annex 13 - Methods to assess the efficiency of securing arrangements for non-standardized cargo

- 3 In table 1 - "Determination of MSL from breaking strength", in the column "Material", the words "web lashing" are inserted below the words "fibre rope" and in the column "MSL", the expression "70% of breaking strength" is inserted below the expression "33% of breaking strength".

**E**

4 ALBERT EMBANKMENT
LONDON SE1 7SR

Telephone: +44 (0)20 7735 7611

Fax: +44 (0)20 7587 3210

Ref. T1/1.02

MSC.1/Circ.1355
30 June 2010

**AMENDMENTS TO THE GUIDELINES FOR SECURING ARRANGEMENTS
FOR THE TRANSPORT OF ROAD VEHICLES ON RO-RO SHIPS
(RESOLUTION A.581(14))**

1 The Maritime Safety Committee, at its eighty-seventh session (12 to 21 May 2010), having considered the proposal by the Sub-Committee on Dangerous Goods, Solid Cargoes and Containers, at its fourteenth session (21 to 25 September 2009), approved amendments to the Guidelines for securing arrangements for the transport of road vehicles on ro-ro ships (resolution A.581(14)), as amended by MSC/Circ.812, set out in the annex.

2 Member Governments are invited to apply the annexed amendments to the Guidelines and bring them to the attention of shipowners, ship operators, shipmasters and crews and all other parties concerned.

ANNEX

**AMENDMENTS TO THE GUIDELINES FOR SECURING ARRANGEMENTS
FOR THE TRANSPORT OF ROAD VEHICLES ON RO-RO SHIPS
(RESOLUTION A.581(14))**

- 1 The existing paragraph 6.1 is replaced by the following:

"6.1 The maximum securing load (MSL) of lashings should not be less than 100 kN and they should be made of material having suitable elongation characteristics. However, for vehicles not exceeding 15 tonnes (GVM), lashings with lower MSL values may be used. The required number and MSL of lashings may be calculated according to annex 13 to the Code of Safe Practice for Cargo Stowage and Securing (CSS Code), taking into consideration the criteria mentioned in paragraph 1.5.1 of the Code."

(TSFS 2013:99)

Dimensionerande accelerationer för sjötransport från svensk hamn

För dimensionering av lastsäkring i lastbärare för sjötransport från svensk hamn ska minst accelerationer enligt nedan användas beroende på i vilket farvatten transporten ska ske.

Farvattnen definieras enligt följande:

Östersjöfart (A): Östersjön samt Kattegatt, begränsad i väster av Jylland och i norr av en linje Lysekil-Skagen.

Nordsjöfart (B): farvatten väster om Östersjöfart begränsad i norr av en linje Kristiansand-Montrose, i väster Storbritannien och i söder av en linje Brest-Lands End.

Oinskränkt fart (C): farvatten utanför Nordsjöfart.

Dessa farvatten kan omfatta samtliga fartområden enligt 1 kap. 3 § fartygssäkerhetsförordningen (2003:438).

Dimensionerande accelerationer för beräkning av säkringskrafter (g är tyngdaccelerationen, 9,8 m/s²)

Säkringsriktning	Tvärskeppsled		Långskeppsled	
	Kraftriktning:	styrbord/ babord	samtidigt vertikalt nedåt	förut/ akterut
Farvatten:				
Östersjöfart (A)	0,5 g	1,0 g	0,3 g	0,5 g
Nordsjöfart (B)	0,7 g	1,0 g	0,3 g	0,3 g
Oinskränkt fart (C)	0,8 g	1,0 g	0,4 g	0,2 g

Accelerationerna i tvärskepps- och långskeppsled antas uppträda var för sig.

Dimensionerande krafter för lastsäkring i en given riktning erhålls genom multiplicering av lastenhetens massa med ovanstående accelerationer. Riktningarna refererar till lastbäraren så som den placeras ombord.

Bilaga 10. Dimensionering av lastsäkringsarrangemang i lastbärare

Dimensionering av ett lastsäkringsarrangemang baseras på lastens och säkringsutrustningens egenskaper. Dimensioneringen ska grundas på beräkningar. Vid dimensionering av arrangemang med lastsäkringsutrustning av sådan art att teoretiska beräkningar inte kan anses tillämpbara, får arrangemanget dimensioneras genom praktiskt prov för funktionskontroll i enlighet med denna bilaga. En funktionskontroll måste kompletteras med beräkningar så att det säkerställs att en erforderlig säkerhetsfaktor inkluderas i lastsäkringsarrangemanget.

Saknas uppgifter om friktionskoefficienter och säkerhetsfaktorer kan följande riktvärden användas vid beräkning av säkringsarrangemang.

Friktionskoefficienter

Tabellen nedan anger riktvärden för friktionskoefficienter för rena och torra ytor, fria från frost, is och snö. Då friktion för aktuell materialkombination inte finns upptagen i tabellen, eller om den inte på annat sätt kan styrkas, ska en friktionskoefficient på maximalt 0,3 användas.

Om godset börjar glida råder glidfriktion som är lägre än den statiska. För lastsäkringsarrangemang som medger viss rörelse av godset ska glidfriktionen användas.

Exempel på lastsäkringsarrangemang som medger viss rörelse av godset är:

- raka surringar
- kryssurrningar
- loopsurrningar
- grimmor.

Överfallssurrningar och förstängning är exempel på lastsäkringsarrangemang som inte anses medge viss rörelse av godset, och där den statiska friktionskoefficienten kan användas.

Generellt kan glidfriktionen uppskattas till maximalt 70 % av den statiska friktionen. Observera att vissa materialkombinationer kan ha betydligt lägre glidfriktion och att tabellen endast gäller för rena och torra ytor.

Materialkombination i kontaktytan	Friktionskoefficient (statisk) $\mu_{statisk}$	Friktionskoefficient (glid)* μ_{glid}
Sågat trä/träpall		
Sågat trä mot plyfa/plywood/trä	0,5	0,4
Sågat trä mot räfflad aluminium	0,4	–
Sågat trä mot stålplåt	0,4	0,3
Sågat trä mot krympfilm	0,3	–

Krympfilm		
Krympfilm mot plyfa	0,4	–
Krympfilm mot räfflad aluminium	0,4	–
Krympfilm mot stålplåt	0,4	–
Krympfilm mot krympfilm	0,4	–
Kartong (obehandlad)		
Kartong mot kartong	0,5	–
Kartong mot sågad träpall	0,5	–
Storsäck		
Storsäck mot sågad träpall	0,4	–
Stål och plåt		
Blankt stål mot blankt stål	0,15	0,1
Blankt stål mot gjutjärn	0,2	–
Plattjärnsbunt mot sågad träregel	0,5	–
Omålad grovplåt mot sågad träregel	0,5	–
Målad grovplåt mot sågad träregel	0,5	–
Omålad grovplåt mot omålad grovplåt	0,4	–
Målad grovplåt mot målad grovplåt	0,3	–
Målat plåtfat mot målat plåtfat	0,2	–
Gummi		
Gummi mot metall	0,65	–
Gummi mot trä	0,7	–

* Där dynamiska friktionskoefficienter ej är kända kan dessa antas som 70 % av den statiska friktionskoefficienten (ustatisk)

Säkerhetsfaktorer

Vid dimensionering av lastsäkringsutrustning används i första hand MSL som är angivna för utrustningen. Saknas sådana uppgifter kan nedanstående tabell användas som ledning vid direkta beräkningar av maximal tillåten belastning enligt formeln:

$$MSL = \frac{MBL}{\text{säkerhetsfaktor}} ; \text{där } MBL \text{ är aktuell brottlast}$$

Utrustning	Säkerhetsfaktor
Kätting, klass 8	2
Tågvirke	3
Spännband	2
Wire, ny	1,3
Wire, återanvänd	3,4
Stålbånd	1,4
Spännmutter (speed lash)	2
Vantskruv, vantsträckare	2
Taggbricka	2
Tvärbräda, böjning	1,5
Distansbräda, knäckning	2
Distansbräda, axiellt tryck*	3
Luftkuddar	2

* Gäller virkesdimensioner större än 50 x 50 mm.

Praktiska prov

Praktiska fullskaleprov kan utföras dels för att bestämma friktionskoefficienten för olika materialkombinationer och dels för att kontrollera säkringsarrangemangets funktion. Observera att fullskaleprov kan medföra betydande risker om lasten börjar glida eller tippa. Prov bör utföras under väl kontrollerade former och med nödvändiga skyddsåtgärder för de medverkande.

Bestämning av statisk friktionskoefficient (μ_{statisk})

Vid bestämning av den statiska friktionskoefficienten placeras lasten osäkrad i lastbäraren och lastbäraren lutar med successivt ökande vinkel. Den statiska friktionskoefficienten bestäms enligt följande samband:

$$\mu_{\text{statisk}} = \tan \alpha$$

där

μ_{statisk} är den statiska friktionskoefficienten

α är lutningsvinkeln vid begynnande glidning

Bestämning av statisk friktionskoefficient
($\mu = \tan \alpha$)

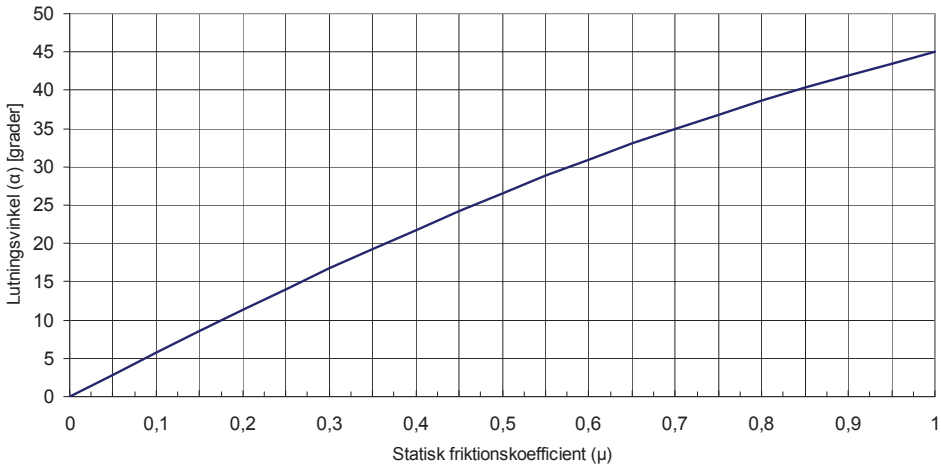

Funktionskontroll av lastsäkringsarrangemang genom praktiska prov

Vid funktionskontroll av lastsäkringsarrangemanget placeras lasten med avsedd säkring applicerad i lastbäraren och lastbäraren lutats till en vinkel som motsvarar de dimensionerande accelerationer som anges nedan.

Erforderlig lutningsvinkel α för en känd friktionskoefficient μ bestäms ur sambandet:

$$m \cdot g \cdot (\sin \alpha - \mu \cdot \cos \alpha) = m \cdot g \cdot (a_h - \mu \cdot a_v)$$

där vänsterledet representerar säkringskrafter för den provade konditionen och där högerledet krafter för den dimensionerande konditionen, och där

$a_h \cdot g$ är dimensionerande acceleration i horisontell led (tvärskepps eller längskepps) och

$a_v \cdot g$ är dimensionerande acceleration i vertikal led.

Erforderlig lutningsvinkel kan beräknas ur nedanstående formler eller bestämmas med hjälp av diagrammet nedan.

$$\alpha = 2 \cdot \arctan \left[\frac{-1 + \sqrt{1 + \mu^2 - \mu^2 \cdot a_v^2 + 2 \cdot \mu \cdot a_v \cdot a_h - a_h^2}}{\mu + \mu \cdot a_v - a_h} \right], \quad \mu \neq \frac{a_h}{1 + a_v}$$

$$\alpha = 2 \cdot \arctan \left[\frac{a_h}{1 + a_v} \right], \quad \mu = \frac{a_h}{1 + a_v}$$

Funktionsprov av säkringsarrangemang

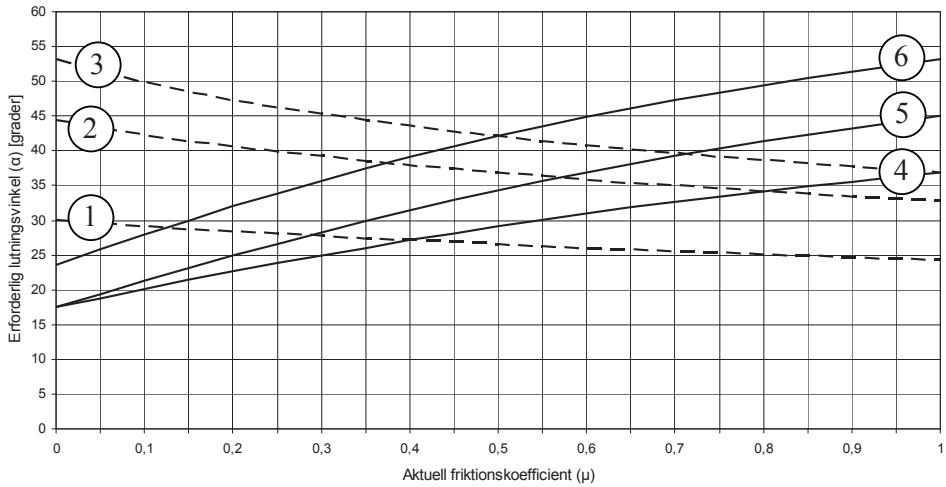

Tvärskeppsled		Långskeppsled	
<i>Kurva</i>	<i>Farvatten</i>	<i>Kurva</i>	<i>Farvatten</i>
1	A	4	A
2	B	5	B
3	C	6	C

LÄMPLIGHETSKRAV FÖR BULKFARTYG

Bulkfartyg som anlöper terminaler i medlemsstaterna för att lasta eller lossa fasta bulkklaster ska uppfylla följande krav:

1. De ska vara försedda med lastrum och lucköppningar av tillräcklig storlek och av en sådan konstruktion att den fasta bulklasten kan lastas, stuvas, trimmas och lossas på ett tillfredsställande sätt.
2. Lastluckorna ska vara försedda med identifieringsnummer som stämmer överens med numren i lastnings- eller lossningsplanen. Dessa nummer ska genom placering, storlek och färg vara väl synliga och identifierbara för den personal som sköter terminalens lastnings- och lossningsutrustning.
3. Lastluckorna, systemen för styrning av lastluckor och säkerhetsanordningarna ska vara i väl fungerande skick och bara användas i avsett syfte.
4. Om lampor som indikerar slagsida har monterats, ska de testas före lastning eller lossning och påvisas vara fungerande.
5. Om det krävs att det ska finnas ett godkänt lastinstrument ombord ska detta vara certifierat och kunna utföra belastningsberäkningar under lastning eller lossning.
6. Framdrivnings- och hjälpmaskineri ska vara väl fungerande.
7. Däcksutrustning som används vid förtöjning ska fungera och vara i gott skick.

LÄMPLIGHETSKRAV FÖR TERMINALER

1. Terminalen ska endast godta bulkfartyg för lastning eller lossning, som på ett säkert sätt kan angöra kajen längs lastnings- eller lossningsanordningen med beaktande av kajplatsens djup, fartygets storlek, förtöjningsanordningar, fendrar, säkert tillträde och möjliga hinder för lastningen eller lossningen.
2. Terminalens lastnings- och lossningsutrustning ska vara korrekt certifierad och hållas i gott skick i enlighet med relevanta regler och normer. Utrustningen får bara skötas av personal som har lämpliga kvalifikationer och erforderliga certifikat.
3. Terminalpersonalen ska utbildas i alla aspekter som rör säker lastning och lossning av bulkfartyg, på ett sätt som är förenligt med vars och ens ansvarsområde. Utbildningen ska vara utformad för att ge kännedom om de allmänna risker som är förknippade med lastning och lossning av fasta bulklaster samt om de negativa följder som felaktiga lastnings- och lossningsförfaranden kan få för fartygets säkerhet.
4. Den terminalpersonal som är delaktig i lastning och lossning ska förseas med och använda personlig skyddsutrustning och ska ges tillfälle till tillräcklig vila för att undvika olyckor till följd av uttrötning.

UPPGIFTER SOM SKA FINNAS MED I EN INFORMATIONSBROSCHYR

Hamninformation

1. Hamnens/terminalens läge.
2. Uppgifter om hamnmyndighet.
3. Radiokommunikation.
4. Uppgifter som ska lämnas i samband med fartygets ankomst.
5. Förfarande vid inklarering.
6. Sjökort och nautiska publikationer.
7. Lotsning.
8. Bogserbåtar.
9. Kajer och ankarplatser.
10. Förfaranden vid nödsituationer.
11. Specifika väderförhållanden.
12. Färskvatten, proviant, bunkers, etc.
13. Största fartyg som hamnen kan ta emot.
14. Maximalt tillåtet djupgående och minsta vattendjup i insegling och hamnområde.
15. Vattnets densitet i hamnen.
16. Maximalt tillåten höjd över vattenytan (air draught).
17. Trim- och djupgåendekrav i insegling och i hamnområde.
18. Tidvatten- och strömförhållanden.
19. Regler för hantering av ballastvatten.
20. Föreskrivna krav angående lasthantering och lastdeklaration.
21. Information om avfallshantering.

Terminalinformation

1. Uppgifter om kontaktpersoner.
2. Tekniska data om kajer och lasthanteringsutrustning.
3. Vattendjup vid kajen.
4. Vattnets densitet vid kajen.
5. Största och minsta storlek på fartyg som terminalen är konstruerad för att kunna ta emot inklusive uppgifter om krav på utrymme mellan däckshus, fartygskranar, etc.
6. Förtöjningsanordningar och passning av förtöjningar.
7. Lasthanteringsutrustningens kapacitet och utrymmeskrav.
8. Lastnings- och lossningsprocedurer.
9. Beräkningar av lastmängd och ”draught survey”.
10. Förutsättningar för att kunna ta emot kombinationsfartyg.
11. Tillträde till och från fartyget och kajer eller pirar.
12. Terminalens förfarande vid nödsituationer.
13. Skador och reglering av skador.
14. Plats på kajen för landgång eller fallrep.
15. Information om avfallshantering.

**INFORMATION SOM BEFÄLHAVAREN
SKA LÄMNA TILL TERMINALEN**

1. Fartygets beräknade ankomsttid till hamnen ska meddelas så tidigt som möjligt. Denna information ska uppdateras efter behov.
2. I samband med att den första ankomsttiden meddelas ska följande upplysningar lämnas:
 - a) Namn, anropssignal, IMO-nummer, flagg, hemmahamn.
 - b) Lastnings- eller lossningsplan med angivande av lastens kvantitet, stuvning per lastrum, lastnings- eller lossningsorder samt den kvantitet som ska lastas ombord i varje omgång eller lossas vid varje steg i lossningen.
 - c) Djupgående vid ankomst och beräknat djupgående vid avgång.
 - d) Tid som krävs för fyllning eller länsning av barlast.
 - e) Fartygets längd över allt och bredd samt lastområdets längd från förkant på luckarmen på det lastrum som är beläget längst för över till akterkant på luckarmen på det lastrum som är beläget längst akter över, i vilka last ska lastas eller lossas.
 - f) Avståndet från vattenlinjen till luckan för det första lastrum som ska lastas eller lossas, samt avståndet från fartygets sida till lucköppningen.
 - g) Placering av fallrepstrappa eller landgång.
 - h) Air draught, dvs. avståndet mellan fartygets högsta punkt och vattenytan.
 - i) Detaljuppgifter om och kapaciteten på fartygets lasthanteringsutrustning, om sådan finns.
 - j) Antal och typ av förtöjningar (trossar, vajrar, etc.).
 - k) Särskilda behov, t.ex. trimning av lasten eller fortlöpande mätning av lastens fukthalt.
 - l) Uppgifter om eventuella, nödvändiga reparationer som kan försena fartygets förtöjning, påbörjandet av lastning eller lossning, eller fartygets avgång efter det att lastning eller lossning genomförts.
 - m) Varje annan upplysning om fartyget som terminalen begär.

BEFÄLHAVARENS FÖRPLIKTELSE FÖRE OCH UNDER LASTNING ELLER LOSSNING

Före och under lastningen eller lossningen ska befälhavaren säkerställa att:

1. lastning eller lossning av last samt fyllning eller länsning av barlastvatten sker under ledning av ansvarigt fartygsbefäl,
2. lastens och barlastvattnets fördelning övervakas under hela lastnings- eller lossningsprocessen för att säkerställa att fartygets konstruktion inte överbelastas,
3. fartyget ligger utan slagsida eller, om slagsida krävs av operationella skäl, att den är så liten som möjligt,
4. fartyget hela tiden är säkert förtöjt med beaktande av väderförhållanden och väderprognoser,
5. ett tillräckligt stort antal befäl och besättningsmän är kvar ombord för att de ska kunna justera förtöjningar eller hantera alla normala situationer eller en nödsituation med beaktande av behovet att ge besättningen tillräckliga viloperioder för att undvika uttrötning,
6. terminalrepresentanten uppmärksammas på krav att trimma lasten i enlighet med förfarandena i Transportstyrelsens föreskrifter (TSFS 2010:166) om transport till sjöss av fast gods i bulk (IMSBC-koden),
7. terminalrepresentanten uppmärksammas på kraven att balansera fyllning eller länsning av barlastvatten mot lastning eller lossning samt varje avvikelser från planen för barlasthanteringen, eller varje annan omständighet som kan påverka lastningen eller lossningen av lasten,
8. barlastvattnet länsas i en takt som stämmer överens med den överenskomna lastningsplanen och inte svämmer över kajen eller intilliggande fartyg; i de fall det inte är praktiskt möjligt för fartyget att fullfölja länsningen av barlastvattnet före lastningsprocessens trimningsfas ska befälhavaren komma överens med terminalrepresentanten om vid vilka tidpunkter och hur länge lastningen kan behöva skjutas upp,
9. det finns en överenskommelse med terminalrepresentanten när det gäller de åtgärder som ska vidtas i händelse av regn eller andra förändringar av väderförhållandena om lasten är av den typen att risker kan uppstå vid sådana förändringar,
10. inget svetsarbete utförs ombord eller i fartygets närhet medan fartyget ligger vid kaj, om inte terminalrepresentanten har gett tillstånd till detta och det utförs i enlighet med eventuella krav från den behöriga myndigheten,

11. noggrann övervakning av lastnings- eller lossningsarbetet samt av fartyget under de avslutande faserna av lastningen eller lossningen,
12. terminalrepresentanten omedelbart underrättas om lastnings- eller lossningsprocessen har orsakat skador, skapat en riskfylld situation eller löper risk att göra detta,
13. terminalrepresentanten informeras när den slutliga trimningen av fartyget måste påbörjas för att lastanläggningens transportanordning ska kunna tömmas,
14. lossningen på babords sida och lossningen på styrbords sida synkroniseras i så hög grad som möjligt i samma lastrum för att undvika att fartyget utsätts för vridpåkänningar, och
15. risken för utsläpp av eventuella brännbara gaser när ett eller flera lastrum fylls med barlast beaktas och försiktighetsåtgärder vidtas innan eventuella svetsarbeten tillåts intill eller ovanför dessa lastrum.

INFORMATION SOM TERMINALEN SKA LÄMNA TILL BEFÄLHAVAREN

1. Namnet på den kaj vid vilken lastning eller lossning ska genomföras och beräknade tidpunkter för förtöjning och avslutad lastning eller lossning.¹
2. Beskrivning av lastnings- eller lossningsutrustningen, inklusive terminalens nominella lastnings- eller lossningstakt och det antal lastnings- eller lossningsenheter som ska användas, liksom hur lång tid som beräknas åtgå för att avsluta varje lastningsomgång, eller hur lång tid som beräknas åtgå för varje steg i lossningen.
3. Uppgifter om kajplatsen eller piren som befälhavaren kan behöva känna till, inklusive placering av fasta och rörliga hinder, fendrar, pollare och förtöjningsanordningar.
4. Minsta vattendjup längs kajen och i inseglsleder.¹
5. Vattendensitet vid kajen.
6. Maximiaavståndet mellan vattenlinjen och högsta punkten på lastluckorna eller luckarmarna, beroende på vilket av dessa avstånd som är relevant för lastningen eller lossningen samt maximalt air draught, dvs. avståndet mellan fartygets högsta punkt och vattenytan.
7. Anordningar för landgångar och tillträde.
8. Vilken av fartygets sidor som ska ligga mot kaj.
9. Högsta tillåtna hastighet vid ingång till kajplatsen samt tillgång till bogserbåtar, inklusive deras typ och största dragkraft.
10. Ordningföljden vid lastning för olika poster av last och varje annan begränsning, om det inte är möjligt att lasta i en ordning eller i ett lastrum som passar fartyget.
11. Uppgifter om varje egenskap som lasten som ska lastas har, som kan medföra risker om lasten kommer i kontakt med last eller lastrester som finns ombord.
12. Förhandsinformation om de föreslagna lastnings- eller lossningsförfarandena eller ändringar av befintliga lastnings- eller lossningsplaner.

¹ Information om beräknade tidpunkter för förtöjning och avgång samt om minsta vattendjup vid kajplatsen ska uppdateras regelbundet och delges befälhavaren vid mottagandet av uppdaterade meddelanden om beräknad ankomsttid. Uppgifter om minsta vattendjup i inseglsleder ska tillhandahållas av antingen terminalen eller den behöriga myndigheten.

13. Om terminalens lastnings- eller lossningsutrustning är fast eller har några begränsningar i fråga om rörlighet.
14. Krav på förtöjningar.
15. Underrättelse om speciella förtöjningsanordningar.
16. Eventuella begränsningar för fyllning eller länsning av barlastvatten.
17. Största djupgående som den behöriga myndigheten tillåter.
18. Varje annan upplysning som befälhavaren begär om terminalen.

TERMINALREPRESENTANTENS FÖRPLIKTELSE FÖRE OCH UNDER LASTNING ELLER LOSSNING

Före och under lastningen eller lossningen ska terminalrepresentanten:

1. informera befälhavaren om namn och förfaranden för att kontakta den terminalpersonal eller den avlastares agent som kommer att ansvara för lastningen eller lossningen, och med vilka befälhavaren kommer att stå i kontakt,
2. vidta alla försiktighetsåtgärder för att undvika att lastnings- eller lossningsutrustningen orsakar skador på fartyget samt, om skador uppstår, informera befälhavaren,
3. säkerställa att fartyget ligger utan slagsida eller, om slagsida krävs av operationella skäl för att lastnings- eller lossningsarbetet ska kunna utföras, att den är så liten som möjligt,
4. säkerställa att lossningen på babords sida synkroniseras med lossningen på styrbords sida när lossningen sker från samma lastrum för att undvika att fartyget utsätts för vridpåkänningar,
5. om det rör sig om laster med hög bulkdensitet eller om enskilda skoplaster är stora, varsko befälhavaren att det kan förekomma höga lokala belastningar på fartygskonstruktionen till dess att tanktaket helt täcks av last, särskilt i det fall det är tillåtet att släppa last från hög höjd, och att särskild försiktighet iakttas när lastningen av varje lastrum påbörjas,
6. säkerställa att det finns en överenskommelse mellan befälhavaren och terminalrepresentanten beträffande alla faser och aspekter av lastningen eller lossningen och att befälhavaren informeras om varje ändring av den överenskomna lastningstakten samt, vid fullbordandet av varje lastningsomgång, den vikt som lastats ombord,
7. protokollföra vikten hos och fördelningen av den last som lastas eller lossas samt säkerställa att lastvikten i lastrummen inte avviker från den överenskomna lastnings- eller lossningsplanen,
8. säkerställa att lasten vid lastning eller lossning har trimmats i enlighet med befälhavarens krav,
9. säkerställa att den lastkvantitet som krävs för att uppnå erforderligt djupgående och trim inför avgången gör det möjligt att tömma lastanläggningens transportanordning när lastningen avslutas; i detta syfte ska terminalrepresentanten informera befälhavaren om den nominella vikten på last som finns i transportanordningen och om eventuella krav på tömning av transportanordningen då lastningen avslutas,

10. vid lossning, i god tid informera befälhavaren när man avser öka eller minska antalet använda lossningsenheter samt underrätta befälhavaren om när lossningen av varje lastrum anses vara avslutad, och
11. säkerställa att inget svetsarbete utförs ombord eller i fartygets närhet medan fartyget ligger vid kaj, förutom med befälhavarens tillstånd och i enlighet med eventuella krav från den behöriga myndigheten.

**CHECKLISTA FARTYG/HAMN FÖR SÄKERHETEN
VID LASTNING ELLER LOSSNING AV BULKFARTYG**

Terminal: Datum Hamn
Terminal/Kaj
Tillgängligt vattendjup vid kajplats
Min. höjd över vattenytan (air draught)¹

Fartyg: Fartygets namn
Djupgående vid ankomst (avläst/beräknat)
Höjd över vattenytan vid ankomst (air draught)
Beräknat djupgående vid avgång
Höjd över vattenytan vid avgång (air draught)

För säker lasthantering krävs att alla frågor besvaras jakande och rutorna kryssas. Om detta inte är möjligt, ska anledningen anges och överenskommelse träffas om vilka försiktighetsåtgärder som ska vidtas mellan fartyg och terminal. Om en fråga inte anses tillämplig skrivs "N/A" (eng. Not Applicable) med förklaring varför, om så är lämpligt.

		Fartyg	Terminal
1.	Är vattendjupet vid kajplatsen och fartygets högsta punkt över vattenytan (air draught) anpassade för lasthanteringen?	<input type="checkbox"/>	<input type="checkbox"/>
2.	Är förtöjningsarrangemangen anpassade för all påverkan på platsen i form av tidvatten, strömmar, väder, trafik och farkoster som befinner sig långsides fartyget?	<input type="checkbox"/>	<input type="checkbox"/>
3.	Kan fartyget i en nödsituation lämna kajen när som helst?	<input type="checkbox"/>	<input type="checkbox"/>
4.	Är förbindelsen mellan fartyg och kaj säker? <i>Vaktas av fartyget</i> <input type="checkbox"/> <i>Terminalen</i> <input type="checkbox"/> (kryssa i lämplig ruta)	<input type="checkbox"/>	<input type="checkbox"/>
5.	Är överenskommet kommunikationssystem mellan fartyg och terminal i drift? <i>Kommunikationsmetod</i> <i>Språk</i> <i>Radiokanaler/telefonnummer</i>	<input type="checkbox"/>	<input type="checkbox"/>
6.	Är kontaktpersonerna för förbindelsen under lastning/lossning säkert identifierade? <i>Kontaktpersoner på fartyget</i> <i>Kontaktperson(er) i land</i> <i>Plats</i>	<input type="checkbox"/>	<input type="checkbox"/>
7.	Finns lämplig personal ombord och i terminalen för en nödsituation?	<input type="checkbox"/>	<input type="checkbox"/>
8.	Finns någon information eller överenskommelse om att fartyget skall hantera bunkers?	<input type="checkbox"/>	<input type="checkbox"/>

¹Termen *höjd över vattenytan* (air draught) ska tolkas med försiktighet: Om fartyget är i en flod eller en flodmynning avses vanligen maximal masthöjd för passage under broar, medan det vid kajplats vanligen avses den höjd som finns att tillgå eller är nödvändig under lastare eller lossare.

		Fartyg	Terminal
9.	Har några planerade reparationer på kajen eller fartyget aviserats och avtalats medan fartyget ligger vid kaj?	<input type="checkbox"/>	<input type="checkbox"/>
10.	Har någon procedur avtalats för rapportering och registrering av skada vid lasthantering?	<input type="checkbox"/>	<input type="checkbox"/>
11.	Har fartyget fått kopior av hamn- och terminalbestämmelser inklusive krav gällande säkerhet och förorening samt information om service vid nödsituationer?	<input type="checkbox"/>	<input type="checkbox"/>
12.	Har avlastaren till befälhavaren lämnat information om lastens egenskaper i enlighet med kraven i kapitel VI i 1974 års SOLAS-konvention?	<input type="checkbox"/>	<input type="checkbox"/>
13.	Är atmosfären säker i lastrum och slutna utrymmen till vilka åtkomst kan behövas, har laster som avger gas identifierats och har behovet av övervakning av atmosfären överenskommit mellan fartyget och terminalen?	<input type="checkbox"/>	<input type="checkbox"/>
14.	Har lasthanteringskapaciteten och ev. rörelsebegränsningar för varje lastare/lossare lämnats till fartyget/terminalen? <i>Lastare/lossare</i> <i>Lastare/lossare</i> <i>Lastare/lossare</i>	<input type="checkbox"/>	<input type="checkbox"/>
15.	Har en lastnings- eller lossningsplan räknats fram för alla stadier av lastning/ballasttömning eller lossning/ballastfyllning? <i>Kopia lämnad till</i>	<input type="checkbox"/>	<input type="checkbox"/>
16.	Är de lastrum som skall lastas/lossas klart identifierade i lastnings- eller lossningsplanen? Framgår turordning i arbetet samt typ och lastmängd som skall förflyttas varje gång lastrummet lastas/lossas?	<input type="checkbox"/>	<input type="checkbox"/>
17.	Har behovet av trimning av last i lastrummen diskuterats och har metod och omfattning avtalats?	<input type="checkbox"/>	<input type="checkbox"/>
18.	Förstår och accepterar både fartyg och terminal att om ballasthanteringen kommer ur fas med lasthanteringen så är det nödvändigt att göra ett uppehåll i lasthanteringen till dess ballasthanteringen har kommit ifatt?	<input type="checkbox"/>	<input type="checkbox"/>
19.	Har tänkta tillvägagångssätt för att vid lossning ta bort lastrester som finns i lastrummen förklarats och accepterats av fartyget?	<input type="checkbox"/>	<input type="checkbox"/>
20.	Har tillvägagångssättet för att justera slutligt trim av det lastande fartyget beslutats och överenskommit? <i>Lastmängd som finns i terminalens transportbandsystem</i>	<input type="checkbox"/>	<input type="checkbox"/>
21.	Har terminalen aviserats om den tid som behövs efter avslutad lasthantering för att göra fartyget sjöklart innan avgång?	<input type="checkbox"/>	<input type="checkbox"/>

OVANSTÅENDE HAR ÖVERENSKOMMITT

Tid Datum

För fartyget För terminalen

Befattning Befattning/Titel

RIKTLINJER VID IFYLLANDE AV CHECKLISTA FÖR FARTYG-/HAMNSÄKERHET

1. *Är vattendjupet vid kajplatsen och fartygets högsta punkt över vattenytan² (air draught) anpassade för lasthanteringen?*

Vattendjupet bör beräknas för hela den yta som fartyget kommer att uppta, och terminalen bör vara medveten om fartygets högsta höjd ovan vattenytan (air draught) samt vilket vattendjup som krävs under hanteringen. I fall då djupgåendet med last medför begränsat vattendjup under kölen vid avgång, bör befälhavaren ta hänsyn till och bekräfta att det föreslagna djupgåendet vid avgång är säkert och tillräckligt.

Till fartyget ska all tillgänglig information lämnas om densitet och föroreningar i vattnet vid kaj.

2. *Är förtöjningsarrangemangen anpassade för all påverkan på platsen, i form av tidvatten, strömmar, väder, trafik och farkoster som befinner sig långsides fartyget?*

Behovet av lämplig avfendring bör beaktas. Fartyget ska ligga väl förtöjt. Längs piler och kajer ska fartygsrörelse förhindras genom att förtöjningarna hålls tajta; hänsyn ska tas till fartygets rörelser på grund av tidvatten, strömmar eller passerande fartyg samt av pågående aktiviteter.

Ställinor och fibertrossar ska inte användas tillsammans i samma riktning på grund av skillnader i deras elastiska egenskaper.

3. *Kan fartyget i en nödsituation lämna kajen när som helst?*

Fartyget ska normalt kunna gå av egen maskin med kort varsel, om inte avtal träffats med terminalrepresentant, och hamnmyndighet där detta är tillämpligt, om att fartyget får immobiliseras.

I en nödsituation kan ett antal faktorer hindra ett fartyg att lämna kajen med kort varsel. Det kan vara ebb, kraftigt trim eller lågt vatten, brist på bogserbåtar, omöjligt att navigera nattetid, stoppad huvudmaskin, etc. Både fartyget och terminalen bör känna till om någon av dessa faktorer gäller, så att extra försiktighetsåtgärder kan vidtas vid behov.

Överenskommelse bör träffas om vilken metod som ska användas för lossläggning vid en nödsituation med hänsyn till inbegripna risker. Om behov skulle uppstå av nödbogsering, ska överenskommelse göras om linornas position och metod för fastsättning.

4. *Är förbindelsen mellan fartyg och kaj säker?*

Utrustningen för förbindelsen mellan fartyg och kaj måste vara säker och uppfylla gällande regelverk och kan bevakas antingen av fartyget eller av terminalen. Den ska bestå av en lämplig landgång eller fallrepstrappa med

²Termen höjd över vattenytan (air draught) ska tolkas med försiktighet: Om fartyget är i en flod eller en flodmyning avses vanligen maximal masthöjd för passage under broar, medan det vid kajplats vanligen avses den höjd som finns att tillgå eller är nödvändig under lastare eller lossare.

ett ordentligt fastgjort underliggande säkerhetsnät. Förbindelsen måste vaktas, eftersom den kan bli skadad p.g.a. varierande höjd och vattendjup; fartyg och terminal måste komma överens om vilka personer som är ansvariga för tillsyn av den. Dessa ska också registreras i checklistan.

Landgången ska placeras så att den inte ligger under det stråk där lastning eller lossning pågår. Den ska vara väl upplyst i mörker. En livboj med kastlina ska finnas ombord på fartyget nära landgången eller fallrepstrappan.

5. *Är överenskommet kommunikationssystem mellan fartyg och terminal i drift?*

Kommunikation mellan vakthavande befäl på fartyget och den ansvarige i land ska upprätthållas på det mest effektiva sättet. Notering ska göras i checklistan om valt kommunikationssystem och vilket språk som ska användas, liksom också nödvändiga telefonnummer och/eller radiokanaler.

6. *Är kontaktpersonerna för förbindelsen under lastning/lossning säkert identifierade?*

Kontrollpersonalen på fartyget och i terminalen måste upprätthålla en effektiv kommunikation med varandra och sina respektive arbetsledare. Deras namn och var de kan kontaktas vid behov ska noteras i checklistan.

7. *Finns lämplig personal ombord och i terminalen för en nödsituation?*

Det är inte möjligt eller önskvärt att specificera alla situationer, men det är viktigt att tillräckligt mycket personal finns ombord på fartyget och i terminalen under fartygets liggetid för att en nödsituation ska kunna hanteras.

De signaler som ska användas i händelse av en nödsituation i land eller ombord ska klart förstås av all personal som är inblandad i lasthantering.

8. *Finns någon information eller överenskommelse om att fartyget ska hantera bunkers?*

Det ska fastställas vilken person ombord som är ansvarig för bunkring, liksom också tid, leveranssätt (slang från kajen, bunkerpråm, etc.) och placering av bunkeranslutningen ombord. Bunkring bör samordnas med lastningsaktiviteterna. Terminalen bör godkänna förfarandet.

9. *Har några planerade reparationer på kajen eller fartyget aviserats och avtalats medan fartyget ligger vid kaj?*

Varmbearbetning (hot work), som inkluderar svetsning, värmning eller öppen låga, oavsett om det är på fartyget eller på kajen, kan kräva tillstånd. Samordning bör ske om arbete på däck kan komma i konflikt med lasthantering.

Om fartyget är ett kombinationsfartyg ska det finnas ett certifikat om gasfritt fartyg, utfärdat i enlighet med Arbetarskyddsstyrelsens kungörelse med föreskrifter (AFS 1986:26) om vissa arbeten på fartyg samt allmänna råd om tillämpningen av föreskrifterna.

10. *Har någon procedur avtalats för rapportering och registrering av skada vid lasthantering?*

Skador på fartyget kan förväntas vid denna typ av hantering. För att undvika konflikt måste man komma överens om en procedur för registrering av sådana skador innan lasthanteringen påbörjas. En ansamling av småskador på stålkonstruktionen kan resultera i betydande förlust av hållfasthet i fartyget, så det är nödvändigt att skada noteras för att möjliggöra snabb reparation.

11. *Har fartyget fått kopior av hamn- och terminalbestämmelser inklusive krav gällande säkerhet och förorening samt information om service vid nödsituationer?*

Fastän mycket information normalt lämnas av fartygets agent bör ett faktablad med denna information lämnas till fartyget vid ankomsten; det ska inkludera alla lokala regler som styr tömning av ballastvatten och rengöring av lastrum.

12. *Har avlastaren till befälhavaren lämnat information om lastens egenskaper i enlighet med kraven i kapitel VI i 1974 års SOLAS-konvention?*

Avlastaren ska lämna uppgifter till befälhavaren om t.ex. typ av last, partikelstorlek, kvantitet att lasta, stuvningsfaktor och grad av fukt i lasten. Transportstyrelsens föreskrifter (TSFS 2010:166) om transport till sjöss av fast gods i bulk (IMSBC-koden) ger anvisningar om detta.

Fartyget ska få information om allt material som kan kontaminera eller påverka planerad last, och fartyget ska säkerställa att lastrummen är fria från sådant material.

13. *Är atmosfären säker i lastrum och slutna utrymmen till vilka åtkomst kan behövas, har laster som avger gas identifierats och har behovet av övervakning av atmosfären överenskommit mellan fartyget och terminalen?*

Rostbildning på stålkonstruktion eller lastens egenskaper kan förorsaka att en riskabel atmosfär utvecklas. Hänsyn ska tas till följande: syreförbrukning i lastrummen; effekten av gasutveckling antingen från last som lossas eller från last i en silo före lastning, varifrån gas kan medföras ombord tillsammans med lasten utan varning till fartyget; och läckage av gas, giftig eller explosiv, från intilliggande lastrum eller andra utrymmen.

14. *Har lasthanteringskapaciteten och eventuella rörelsebegränsningar för varje lastare/lossare lämnats till fartyget/terminalen?*

Avtal ska träffas om antal lastare eller lossare som ska användas och deras kapacitet ska klargöras för båda parter. Avtalad maximal lastomsättning för varje lastare/lossare ska noteras i checklistan.

Rörelsebegränsningar i lastnings- eller lossningsutrustning ska anges. Detta är väsentlig information vid planering av lasthantering vid kajer där

ett fartyg måste förhalas från en position till en annan p.g.a. lastning. Kontroll ska alltid göras att utrustningen är felfri och att den är fri från förorening från föregående last. Vågars exakthet ska kontrolleras ofta.

15. *Har en lastnings- eller lossningsplan räknats fram för alla stadier av lastning/ballasttömning eller lossning/ballastfyllning?*

Fartyget bör om möjligt göra planen klar före ankomst. I detta syfte bör terminalen lämna den information fartyget begär för planering. På fartyg som behöver beräkningar på långskeppspåkänningar ska planen ta med alla tolererbara högsta värden för böjmoment och tvärkrafter.

Planen ska stämmas av med terminalen och en kopia lämnas över för terminalpersonalens behov. Alla vakthavande befäl ombord och arbetsledare i terminalen ska ha tillgång till en kopia. Ingen avvikelse från planen ska tillåtas utan överenskommelse med befälhavaren.

16. *Är de lastrum som ska lastas/lossas klart identifierade i lastnings- eller lossningsplanen? Framgår turordning i arbetet samt typ och lastmängd som ska förflyttas varje gång lastrummet lastas/lossas?*

Nödändig information ska lämnas i ett formulär enligt bilaga 7 i dessa föreskrifter.

17. *Har behovet av trimning av last i lastrummen diskuterats och har metod och omfattning avtalats?*

En välkänd metod är trimning genom transportör, varigenom ett tillfredsställande resultat vanligen kan nås. I andra metoder används bulldozers, frontlastare, deflektorblad, trimningsmaskiner eller t.o.m. manuell trimning. Graden av trimning beror på lastens beskaffenhet och måste vara i enlighet med Transportstyrelsens föreskrifter (TSFS 2010:166) om transport till sjöss av fast gods i bulk (IMSBC-koden).

18. *Förstår och accepterar både fartyg och terminal att om ballasthanteringen kommer ur fas med lasthanteringen så är det nödvändigt att göra ett uppehåll i lasthanteringen till dess ballasthanteringen har kommit ifatt?*

Alla parter föredrar att om möjligt lasta och lossa utan avbrott. Befälhavaren måste dock beordra stopp i lasthanteringen om last- eller ballastprogrammen inte är i fas, vilket måste accepteras av terminalen för att undvika alltför stora påkänningar i fartygskonstruktionen.

En lasthanteringsplan anger ofta kontrollpunkter då möjlighet ges att säkerställa att last- och ballasthantering ligger i fas.

Om den högsta hastighet vid vilken fartyget säkert kan ta emot lasten är lägre än terminalens kapacitet att hantera lasten, kan det vara nödvändigt att komma överens om uppehåll i lastningsprogrammet eller för terminalen att köra utrustningen under maximal kapacitet.

I områden där man kan räkna med extremt kallt väder ska möjligheten till frusen ballast eller ballastledning beaktas.

19. *Har tänkta tillvägagångssätt för att vid lossning ta bort lastrester som finns i lastrummen förklarats och accepterats av fartyget?*

Användningen av bulldozers, frontlastare eller pneumatiska/hydrauliska hammare för att skaka loss material ska utnyttjas med försiktighet, eftersom felaktig hantering kan skada eller förändra fartygets stålkonstruktion.

Avtal i förväg om behovet och tänkt metod, tillsammans med lämplig övervakning av operatörerna, kan göra att senare krav på skadeersättning eller försvagning av fartygskonstruktionen elimineras.

20. *Har tillvägagångssättet för att justera slutligt trim av det lastande fartyget beslutats och överenskommit?*

De lastmängder som föreslås i början av lastningen för att justera fartygets trim kan endast bli preliminära och ska inte tillmätas alltför stor betydelse. Avsikten är att se till att kravet inte förbises eller ignoreras. De verkliga kvantiteterna och positionerna för att nå fartygets slutliga trim beror på de föreslagna värden som avläses alldeles innan lastningen avslutas. Fartyget bör informeras om lastmängd i transportbandsystemet, eftersom den kvantiteten kan vara stor men ändå måste lossas när ordern ”stoppa lastning” ges. Denna siffra ska noteras i checklistan.

21. *Har terminalen aviserats om den tid som behövs efter avslutad lasthantering för att göra fartyget sjöklart innan avgång?*

Processen att göra sjöklart före avgång är alltid lika viktig och ska inte nonchaleras. Lastluckorna ska fortlöpande säkras efter avslutad lasthantering så att endast en eller två återstår att stänga när lasthanteringen är avslutad.

Moderna djupvattenterminaler för stora fartyg kan ha mycket korta passager innan öppet vatten nås. Den tid som behövs för att säkra kan därför variera mellan dag eller natt, sommar eller vinter, bra eller dåligt väder. Terminalen måste aviseras i god tid om liggetiden behöver förlängas.

MSC 59/33

ANNEX 35

RESOLUTION MSC.23(59)

(adopted on 23 May 1991)

ADOPTION OF THE INTERNATIONAL CODE FOR THE
SAFE CARRIAGE OF GRAIN IN BULK

THE MARITIME SAFETY COMMITTEE,

RECALLING Article 28(b) of the Convention on the International Maritime Organization concerning the functions of the Committee,

NOTING part C of revised chapter VI of the International Convention for the Safety of Life at Sea, 1974 (SOLAS 74), adopted by resolution MSC.22(59) which, *inter alia*, makes the provisions of the International Code for the Safe Carriage of Grain in Bulk mandatory under that Convention,

HAVING CONSIDERED the text of the proposed Code,

1. ADOPTS the International Code for the Safe Carriage of Grain in Bulk, the text of which is set out in the Annex to the present resolution;
2. DECIDES that the Code shall take effect on 1 January 1994*; and
3. REQUESTS the Secretary-General to transmit to the Members of the Organization and all Contracting Governments to SOLAS 74 certified copies of the present resolution and the Code.

* Date of entry into force of amendments to SOLAS chapter VI.

ANNEX

PART A

SPECIFIC REQUIREMENTS

1 APPLICATION

1.1 This Code applies to ships regardless of size, including those of less than 500 tons gross tonnage, engaged in the carriage of grain in bulk, to which part C of chapter VI of the 1974 SOLAS Convention, as amended, applies.

1.2 For the purpose of this Code:

the expression "ships constructed" means "ships the keels of which are laid or which are at a similar stage of construction";

2 DEFINITIONS

2.1 The term "grain" covers wheat, maize (corn), oats, rye, barley, rice, pulses, seeds and processed forms thereof, whose behaviour is similar to that of grain in its natural state.

2.2 The term "filled compartment, trimmed", refers to any cargo space in which, after loading and trimming as required under A 10.2, the bulk grain is at its highest possible level.

2.3 The term "filled compartment, untrimmed", refers to a cargo space which is filled to the maximum extent possible in way of the hatch opening but which has not been trimmed outside the periphery of the hatch opening either by the provisions of A 10.3.1 for all ships, A 10.3.2 for specially suitable compartments.

2.4 The term "partly filled compartment" refers to any cargo space wherein the bulk grain is not loaded in the manner prescribed in A 2.2 or A 2.3.

2.5 The term "angle of flooding" (θ_1) means the angle of heel at which openings in the hull, superstructures or deckhouses, which cannot be closed weathertight, immerse. In applying this definition, small openings through which progressive flooding cannot take place need not be considered as open.

2.6 The term "stowage factor", for the purposes of calculating the grain heeling moment caused by a shift of grain, means the volume per unit weight of the cargo as attested by the loading facility, i.e. no allowance shall be made for lost space when the cargo space is nominally filled.

2.7 The term "specially suitable compartment" refers to a cargo space which is constructed with at least two vertical or sloping, longitudinal, grain-tight divisions which are coincident with the hatch side girders or are so positioned as to limit the effect of any transverse shift of grain. If sloping, the divisions shall have an inclination of not less than 30° to the horizontal.

3 DOCUMENT OF AUTHORIZATION

3.1 A document of authorization shall be issued for every ship loaded in accordance with the regulations of this Code either by the Administration or an organization recognized by it or by a Contracting Government on behalf of the Administration. It shall be accepted as evidence that the ship is capable of complying with the requirements of these regulations.

3.2 The document shall accompany or be incorporated into the grain loading manual provided to enable the master to meet the requirements of A 7. The manual shall meet the requirements of A 6.3.

3.3 Such a document, grain loading stability data and associated plans may be drawn up in the official language or languages of the issuing country. If the language used is neither English nor French, the text shall include a translation into one of these languages.

3.4 A copy of such a document, grain loading stability data and associated plans shall be placed on board in order that the master, if so required, shall produce them for the inspection of the Contracting Government of the country of the port of loading.

3.5 A ship without such a document of authorization shall not load grain until the master demonstrates to the satisfaction of the Administration, or of the Contracting Government of the port of loading acting on behalf of the Administration, that, in its loaded condition for the intended voyage, the ship complies with the requirements of this Code. See also A 8.3 and A 9.

4 EQUIVALENTS

Where an equivalent accepted by the Administration in accordance with regulation I/5 of the International Convention for the Safety of Life at Sea, 1974, as amended, is used, particulars shall be included in the document of authorization or in the grain loading manual.

5 EXEMPTIONS FOR CERTAIN VOYAGES

The Administration, or a Contracting Government on behalf of the Administration, may, if it considers that the sheltered nature and conditions of the voyage are such as to render the application of any of the requirements of this Code unreasonable or unnecessary, exempt from those particular requirements individual ships or classes of ships.

6 INFORMATION REGARDING SHIP'S STABILITY AND GRAIN LOADING

6.1 Information in printed booklet form shall be provided to enable the master to ensure that the ship complies with this Code when carrying grain in bulk on an international voyage. This information shall include that which is listed in A 6.2 and A 6.3.

6.2 Information which shall be acceptable to the Administration or to a Contracting Government on behalf of the Administration shall include:

- .1 ship's particulars;
- .2 lightship displacement and the vertical distance from the intersection of the moulded base line and midship section to the centre of gravity (KG);

- .3 table of liquid free surface corrections;
- .4 capacities and centres of gravity;
- .5 curve or table of angle of flooding, where less than 40°, at all permissible displacements;
- .6 curves or tables of hydrostatic properties suitable for the range of operating drafts; and
- .7 cross curves of stability which are sufficient for the purpose of the requirements in A 7 and which include curves at 12° and 40°.

6.3 Information which shall be approved by the Administration or by a Contracting Government on behalf of the Administration shall include:

- .1 curves or tables of volumes, vertical centres of volumes, and assumed volumetric heeling moments for every compartment, filled or partly filled, or combination thereof, including the effects of temporary fittings;
- .2 tables or curves of maximum permissible heeling moments for varying displacements and varying vertical centres of gravity to allow the master to demonstrate compliance with the requirements of A 7.1;

this requirement shall apply only to ships the keels of which are laid on or after the entry into force of this Code;
- .3 details of the scantlings of any temporary fittings and, where applicable, the provisions necessary to meet the requirements of A 7, A 8 and A 9;
- .4 loading instructions in the form of notes summarizing the requirements of this Code;
- .5 a worked example for the guidance of the master; and
- .6 typical loaded service departure and arrival conditions and where necessary intermediate worst service conditions*.

7 STABILITY REQUIREMENTS

7.1 The intact stability characteristics of any ship carrying bulk grain shall be shown to meet, throughout the voyage, at least the following criteria after taking into account in the manner described in part B of this Code and, in figure A 7, the heeling moments due to grain shift:

* It is recommended that loading conditions be provided for three representative stowage factors, e.g. 1.25, 1.50, and 1.75 cubic metres per tonne.

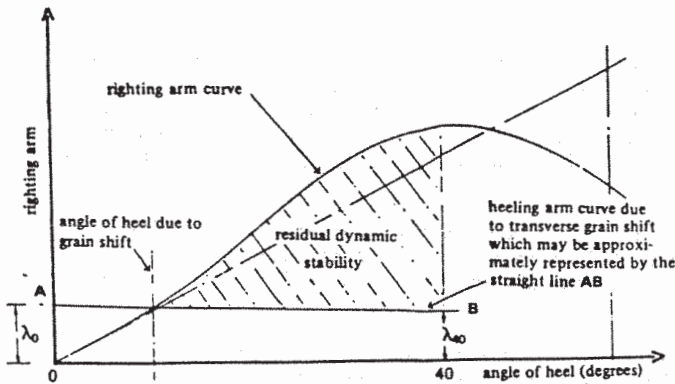

Figure A7

Notes on figure A7:

(1) Where:

$$\lambda_0 = \frac{\text{assumed volumetric heeling moment due to transverse shift}}{\text{stowage factor} \times \text{displacement}}$$

$$\lambda_{40} = 0.8 \times \lambda_0;$$

Stowage factor = volume per unit weight of grain cargo;

Displacement = weight of ship, fuel, fresh water, stores etc. and cargo.

(2) The righting arm curve shall be derived from cross-curves which are sufficient in number to accurately define the curve for the purpose of these requirements and shall include cross-curves at 12° and 40°.

- .1 the angle of heel due to the shift of grain shall not be greater than 12° or in the case of ships constructed on or after 1 January 1994 the angle at which the deck edge is immersed, whichever is the lesser;
- .2 in the statical stability diagram, the net or residual area between the heeling arm curve and the righting arm curve up to the angle of heel of maximum difference between the ordinates of the two curves, or 40° or the angle of flooding (θ_1), whichever is the least, shall in all conditions of loading be not less than 0.075 metre-radians; and
- .3 the initial metacentric height, after correction for the free surface effects of liquids in tanks, shall be not less than 0.30 m.

7.2 Before loading bulk grain the master shall, if so required by the Contracting Government of the country of the port of loading, demonstrate the ability of the ship at all stages of any voyage to comply with the stability criteria required by this section.

7.3 After loading, the master shall ensure that the ship is upright before proceeding to sea.

8 STABILITY REQUIREMENTS FOR EXISTING SHIPS

8.1 For the purposes of this section the term "existing ship" means a ship, the keel of which is laid before 25 May 1980.

MSC 59/33
ANNEX 35
Page 6

8.2 An existing ship loaded in accordance with documents previously approved under regulation 12 of chapter VI of SOLAS 1960, IMO resolutions A.184(VI) or A.264(VIII) shall be considered to have intact stability characteristics at least equivalent to the requirements of A 7 of this Code. Documents of authorization permitting such loadings shall be accepted for the purposes of A 7.2.

8.3 Existing ships not having on board a document of authorization issued in accordance with A 3 of this Code may apply the provisions of A 9 without limitation of the deadweight which may be used for the carriage of bulk grain.

9 OPTIONAL STABILITY REQUIREMENTS FOR SHIPS WITHOUT DOCUMENTS OF AUTHORIZATION CARRYING PARTIAL CARGOES OF BULK GRAIN

9.1 A ship not having on board a document of authorization issued in accordance with A 3 of this Code may be permitted to load bulk grain provided that:

- .1 the total weight of the bulk grain shall not exceed one third of the deadweight of the ship;
- .2 all "filled compartments, trimmed" shall be fitted with centreline divisions extending, for the full length of such compartments, downwards from the underside of the deck or hatch covers to a distance below the deck line of at least one eighth of the maximum breadth of the compartment or 2.4 m, whichever is the greater except that saucers constructed in accordance with A 14 may be accepted in lieu of a centreline division in and beneath a hatchway except in the case of linseed and other seeds having similar properties;
- .3 all hatches to "filled compartments, trimmed" shall be closed and covers secured in place;
- .4 all free grain surfaces in partly filled cargo space shall be trimmed level and secured in accordance with A 16, A 17 or A 18;
- .5 throughout the voyage the metacentric height after correction for the free surface effects of liquids in tanks shall be 0.3 m or that given by the following formula whichever is the greater:

$$GM_R = \frac{L B V_d (0.25 B - 0.645 \sqrt{V_d B})}{SF \times \Delta \times 0.0875}$$

Where:

L = total combined length of all full compartments (metres)

B = moulded breadth of the vessel (metres)

SF = stowage factor (cubic metres per tonne)

V_d = calculated average void depth calculated in accordance with B.1 (metres - Note: not millimetres)

Δ = displacement (tonnes); and

- .6 the master demonstrates to the satisfaction of the Administration or the Contracting Government of the port of loading on behalf of the Administration that the ship in its proposed loaded condition will comply with the requirements of this section.

) STOWAGE OF BULK GRAIN

- .1 All necessary and reasonable trimming shall be performed to level all free grain surfaces and to minimize the effect of grain shifting.
- .2 In any "filled compartment, trimmed", the bulk grain shall be trimmed as to fill all spaces under the decks and hatch covers to the maximum extent possible.
- .3 In any "filled compartment, untrimmed" the bulk grain shall be filled to the maximum extent possible in way of the hatch opening but may be at its natural angle of repose outside the periphery of the hatch opening. A "filled compartment" may qualify for this classification if it falls into one of the following categories:
 - .1 the Administration issuing the document of authorization may, under B 6, grant dispensation from trimming in those cases where the underdeck void geometry resulting from free flowing grain into a compartment, which may be provided with feeder ducts, perforated decks or other similar means, is taken into account when calculating the void depths; or
 - .2 the compartment is "specially suitable" as defined in A 2.7, in which case dispensation may be granted from trimming the ends of that compartment.
- .4 If there is no bulk grain or other cargo above a lower cargo space containing grain, the hatch covers shall be secured in an approved manner having regard to the mass and permanent arrangements provided for securing such covers.
- .5 When bulk grain is stowed on top of closed 'tween-deck hatch covers which are not grain-tight, such covers shall be made grain-tight by taping the joints, covering the entire hatchway with tarpaulins or separation cloths, or other suitable means.
- .6 After loading, all free grain surfaces in "partly filled compartments" shall be level.
- .7 Unless account is taken of the adverse heeling effect due to the grain shift according to this Code, the surface of the bulk grain in any partly filled compartment" shall be secured so as to prevent a grain shift by overstowing as described in A 16. Alternatively, in "partly filled compartments", the bulk grain surface may be secured by strapping or lashing as described in A 17 or A 18.
- .8 Lower cargo spaces and 'tween-deck spaces in way thereof may be loaded as one compartment provided that, in calculating transverse heeling moments, proper account is taken of the flow of grain into the lower spaces.

MSC 59/33

ANNEX 35

Page 8

10.9 In "filled compartments, trimmed", "filled compartments, untrimmed", and "partly filled compartments", longitudinal divisions may be installed as a device to reduce the adverse heeling effect of grain shift provided that:

- .1 the division is grain-tight;
- .2 the construction meets the requirements of A 11, A 12 and A 13; and
- .3 in 'tween-decks the division extends from deck to deck and in other cargo spaces the division extends downwards from the underside of the deck or hatch covers, as described in B 2.8.2, note (2), B 2.9.2, note (3), or B 5.2, as applicable.

11 STRENGTH OF GRAIN FITTINGS

11.1 Timber

All timber used for grain fittings shall be of good sound quality and of a type and grade which has been proved to be satisfactory for this purpose. The actual finished dimensions of the timber shall be in accordance with the dimensions specified below. Plywood of an exterior type bonded with waterproof glue and fitted so that the direction of the grain in the face plies is perpendicular to the supporting uprights or binder may be used provided that its strength is equivalent to that of solid timber of the appropriate scantlings.

11.2 Working stresses

When calculating the dimensions of divisions loaded on one side, using tables A 13-1 to A 13-6, the following working stresses should be adopted:

For divisions of steel 19.6 kN/cm^2

For divisions of wood 1.57 kN/cm^2

(1 newton is equivalent to 0.102 kilograms)

11.3 Other materials

Materials other than wood or steel may be approved for such divisions provided that proper regard has been paid to their mechanical properties.

11.4 Uprights

- .1 Unless means are provided to prevent the ends of uprights being dislodged from their sockets, the depth of housing at each end of each upright shall be not less than 75 mm. If an upright is not secured at the top, the uppermost shore or stay shall be fitted as near thereto as is practicable.
- .2 The arrangements provided for inserting shifting boards by removing a part of the cross-section of an upright shall be such that the local level of stresses is not unduly high.

- .3 The maximum bending moment imposed upon an upright supporting a division loaded on one side shall normally be calculated assuming that the ends of the uprights are freely supported. However, if an Administration is satisfied that any degree of fixity assumed will be achieved in practice, account may be taken of any reduction in the maximum bending moment arising from any degree of fixity provided at the ends of the upright.

11.5 Composite section

Where uprights, binders or any other strength members are formed by two separate sections, one fitted on each side of a division and interconnected by through bolts at adequate spacing, the effective section modulus shall be taken as the sum of the two moduli of the separate sections.

11.6 Partial division

Where divisions do not extend to the full depth of the cargo space such divisions and their uprights shall be supported or stayed so as to be as efficient as those which do extend to the full depth of the cargo space.

12 DIVISIONS LOADED ON BOTH SIDES

12.1 Shifting boards

- .1 Shifting boards shall have a thickness of not less than 50 mm and shall be fitted grain-tight and where necessary supported by uprights.
- .2 The maximum unsupported span for shifting boards of various thicknesses shall be as follows:

Thickness	Maximum unsupported span
50 mm	2.5 m
60 mm	3.0 m
70 mm	3.5 m
80 mm	4.0 m.

If thicknesses greater than these are provided the maximum unsupported span will vary directly with the increase in thickness.

- .3 The ends of all shifting boards shall be securely housed with 75 mm minimum bearing length.

12.2 Other materials

Divisions formed by using materials other than wood shall have a strength equivalent to the shifting boards required in A 12.1.

12.3 Uprights

- .1 Steel uprights used to support divisions loaded on both sides shall have a section modulus given by

$$W = a \times W_1$$

Where:

W = section modulus in cubic centimetres;
a = horizontal span between uprights in metres.

The section modulus per metre span W_1 shall be not less than that given by the formula:

$$W_1 = 14.8(h_1 - 1.2)cm^3/m$$

Where:

h_1 is the vertical unsupported span in metres and shall be taken as the maximum value of the distance between any two adjacent stays or between a stay and either end of the upright. Where this distance is less than 2.4 m the respective modulus shall be calculated as if the actual value were 2.4 m.

- .2 The moduli of wood uprights shall be determined by multiplying by 12.5 the corresponding moduli for steel uprights. If other materials are used their moduli shall be at least that required for steel increased in proportion to the ratio of the permissible stresses for steel to that of the material used. In such cases attention shall be paid also to the relative rigidity of each upright to ensure that the deflection is not excessive.
- .3 The horizontal distance between uprights shall be such that the unsupported spans of the shifting boards do not exceed the maximum span specified in A 12.1.3.

12.4 Shores

- .1 Wood shores, when used, shall be in a single piece and shall be securely fixed at each end and heeled against the permanent structure of the ship except that they shall not bear directly against the side plating of the ship.
- .2 Subject to the provisions of A 12.4.3 and A 12.4.4, the minimum size of wood shores shall be as follows:

Length of shore in metres	Rectangular section mm	Diameter of circular section mm
Not exceeding 3 m	150 x 100	140
Over 3 m but not exceeding 5 m	150 x 150	165
Over 5 m but not exceeding 6 m	150 x 150	180
Over 6 m but not exceeding 7 m	200 x 150	190
Over 7 m but not exceeding 8 m	200 x 150	200
Exceeding 8 m	200 x 150	215

Shores of 7 m or more in length shall be securely bridged at approximately mid-length.

- .3 When the horizontal distance between the uprights differs significantly from 4 m the moments of inertia of the shores may be changed in direct proportion.
- .4 Where the angle of the shore to the horizontal exceeds 10° the next larger shore to that required by A 12.4.2 shall be fitted provided that in no case shall the angle between any shore and the horizontal exceed 45°.

12.5 Stays

Where stays are used to support divisions loaded on both sides, they shall be fitted horizontally or as near thereto as practicable, well secured at each end and formed of steel wire rope. The sizes of the wire rope shall be determined assuming that the divisions and upright which the stay supports are uniformly loaded at 4.9 kN/m². The working load so assumed in the stay shall not exceed one third of its breaking load.

13 DIVISIONS LOADED ON ONE SIDE ONLY

13.1 Longitudinal divisions

The load (P) in newtons per metre length of the divisions shall be taken as follows:

.1 Table A 13-1

B (m)								
a (m)	2	3	4	5	6	7	8	10
1.50	8.336	8.826	9.905	12.013	14.710	17.358	20.202	25.939
2.00	13.631	14.759	16.769	19.466	22.506	25.546	28.733	35.206
2.50	19.466	21.182	23.830	26.870	30.303	33.686	37.265	44.473
3.00	25.644	27.900	30.891	34.323	38.099	41.874	45.797	53.740
3.50	31.823	34.568	37.952	41.727	45.895	50.014	54.329	63.008
4.00	38.148	41.286	45.013	49.180	53.691	58.202	62.861	72.275
4.50	44.473	47.955	52.073	56.584	61.488	66.342	71.392	81.542
5.00	50.847	54.623	59.134	64.037	69.284	74.531	79.924	90.810
6.00	63.498	68.009	73.256	78.894	84.877	90.859	96.988	109.344

Where: h = height of grain in metres from the bottom of the division. When the cargo space is filled, the height (h) shall be taken to the overhead deck in way of the division. In a hatchway or where the distance from a division to a hatchway is 1 m or less, the height (h) shall be taken to the level of the grain in the hatchway.

B = transverse extent of the bulk grain in metres.

- .2 Linear interpolation within table A 13-1 may be used for intermediate values of B and for intermediate values of h when h is equal to or less than 6.0 m.
- .3 For values of h exceeding 6.0 m the load (P) in newtons per metre length of the divisions may be determined from table A 13-2 by entering with the ratio B/h and utilizing the formula:

$$P = f \times h^2$$

- .4 Table A 13-2

B/h	f	B/h	f
0.2	1.687	2.0	3.380
0.3	1.742	2.2	3.586
0.4	1.809	2.4	3.792
0.5	1.889	2.6	3.998
0.6	1.976	2.8	4.204
0.7	2.064	3.0	4.410
0.8	2.159	3.5	4.925
1.0	2.358	4.0	5.440
1.2	2.556	5.0	6.469
1.4	2.762	6.0	7.499
1.6	2.968	8.0	9.559
1.8	3.174		

13.2 Transverse divisions

The load (P) in newtons per metre length of the divisions shall be taken as follows:

.1 Table A 13-3

L (m)											
h(m)	2	3	4	5	6	7	8	10	12	14	16
1.50	6.570	6.767	7.159	7.649	8.189	8.728	9.169	9.807	10.199	10.297	10.297
2.00	10.199	10.787	11.474	12.209	12.994	13.729	14.416	15.445	16.083	16.279	16.279
2.50	14.318	15.347	16.426	17.456	18.437	19.417	20.349	21.673	22.408	22.604	22.604
3.00	18.878	20.251	21.624	22.948	24.222	25.399	26.429	27.900	28.684	28.930	28.930
3.50	23.781	25.546	27.164	28.733	30.155	31.430	32.558	34.127	35.010	35.255	35.255
4.00	28.930	30.989	32.901	34.667	36.187	37.559	38.736	40.403	41.286	41.531	41.580
4.50	34.274	36.530	38.638	40.501	42.120	43.542	44.767	46.582	47.562	47.856	47.905
5.00	39.717	42.218	44.473	46.434	48.151	49.622	50.897	52.809	53.839	54.182	54.231
6.00	50.749	53.593	56.094	58.301	60.164	61.782	63.204	65.263	66.440	66.832	66.930

Where: h = height of grain in metres from the bottom of the division. When the cargo space is filled, the height (h) shall be taken to the overhead deck in way of the division. In a hatchway, or where the distance from a division to a hatchway is 1 m or less, the height (h) shall be taken to the level of the grain in the hatchway.

L = longitudinal extent of the bulk grain in metres.

.2 Intermediate values of L and intermediate values of h when h is equal to or less than 6.0 m may be determined by linear interpolation using table A 13-3.

.3 For values of h exceeding 6.0 m the load (P) in newtons per metre length of the divisions may be determined from table A 13-4 by entering with the ratio L/h and utilizing the formula:

$$P = f \times h^2$$

.4 Table A 13-4

L/h	f	L/h	f
0.2	1.334	2.0	1.846
0.3	1.395	2.2	1.853
0.4	1.444	2.4	1.857
0.5	1.489	2.6	1.859
0.6	1.532	2.8	1.859
0.7	1.571	3.0	1.859
0.8	1.606	3.5	1.859
1.0	1.671	4.0	1.859
1.2	1.725	5.0	1.859
1.4	1.769	6.0	1.859
1.6	1.803	8.0	1.859
1.8	1.829		

13.3 The total load per unit length of divisions shown in tables A 13-1 to A 13-4 inclusive may, if considered necessary, be assumed to have a trapezoidal distribution with height. In such cases, the reaction loads at the upper and lower ends of a vertical member or upright are not equal. The reaction loads at the upper end expressed as percentages of the total load supported by the vertical member or upright may be taken to be those shown in tables A 13-5 and A 13-6.

.1 Table A 13-5: Longitudinal divisions loaded on one side only

Bearing reaction at the upper end of upright as a percentage of load from A 13.1

B (m)								
h (m)	2	3	4	5	6	7	8	10
1.5	43.3	45.1	45.9	46.2	46.2	46.2	46.2	46.2
2	44.5	46.7	47.6	47.8	47.8	47.8	47.8	47.8
2.5	45.4	47.6	48.6	48.8	48.8	48.8	48.8	48.8
3	46.0	48.3	49.2	49.4	49.4	49.4	49.4	49.4
3.5	46.5	48.8	49.7	49.8	49.8	49.8	49.8	49.8
4	47.0	49.1	49.9	50.1	50.1	50.1	50.1	50.1
4.5	47.4	49.4	50.1	50.2	50.2	50.2	50.2	50.2
5	47.7	49.4	50.1	50.2	50.2	50.2	50.2	50.2
6	47.9	49.5	50.1	50.2	50.2	50.2	50.2	50.2
7	47.9	49.5	50.1	50.2	50.2	50.2	50.2	50.2
8	47.9	49.5	50.1	50.2	50.2	50.2	50.2	50.2
9	47.9	49.5	50.1	50.2	50.2	50.2	50.2	50.2
10	47.9	49.5	50.1	50.2	50.2	50.2	50.2	50.2

B = transverse extent of the bulk grain in metres

For other values of h or B the reaction loads shall be determined by linear interpolation or extrapolation as necessary.

.2 Table A 13-6: Transverse divisions loaded on one side only

Bearing reaction at the upper end of upright as a percentage of load from A 13.2

L (m)											
h(m)	2	3	4	5	6	7	8	10	12	14	16
1.5	37.3	38.7	39.7	40.6	41.4	42.1	42.6	43.6	44.3	44.8	45.0
2	39.6	40.6	41.4	42.1	42.7	43.1	43.6	44.3	44.7	45.0	45.2
2.5	41.0	41.8	42.5	43.0	43.5	43.8	44.2	44.7	45.0	45.2	45.2
3	42.1	42.8	43.3	43.8	44.2	44.5	44.7	45.0	45.2	45.3	45.3
3.5	42.9	43.5	43.9	44.3	44.6	44.8	45.0	45.2	45.3	45.3	45.3
4	43.5	44.0	44.4	44.7	44.9	45.0	45.2	45.4	45.4	45.4	45.4
5	43.9	44.3	44.6	44.8	45.0	45.2	45.3	45.5	45.5	45.5	45.5
6	44.2	44.5	44.8	45.0	45.2	45.3	45.4	45.6	45.6	45.6	45.6
7	44.3	44.6	44.9	45.1	45.3	45.4	45.5	45.6	45.6	45.6	45.6
8	44.3	44.6	44.9	45.1	45.3	45.4	45.5	45.6	45.6	45.6	45.6
9	44.3	44.6	44.9	45.1	45.3	45.4	45.5	45.6	45.6	45.6	45.6
10	44.3	44.6	44.9	45.1	45.3	45.4	45.5	45.6	45.6	45.6	45.6

L = longitudinal extent of the bulk grain in metres

For other values of h or L the reaction loads shall be determined by linear interpolation or extrapolation as necessary.

- .3 The strength of the end connections of such vertical members or uprights may be calculated on the basis of the maximum load likely to be imposed at either end. These loads are as follows:

Longitudinal divisions

Maximum load at the top 50% of the appropriate total load from A 13.1

Maximum load at the bottom 55% of the appropriate total load from A 13.1

Transverse divisions

Maximum load at the top 45% of the appropriate total load from A 13.2

Maximum load at the bottom 60% of the appropriate total load from A 13.2

- .4 The thickness of horizontal wooden boards may also be determined having regard to the vertical distribution of the loading represented by tables A 13-5 and A 13-6 and in such cases

$$t = 10a \sqrt{\frac{p \times k}{h \times 2091.8}}$$

Where:

- t = thickness of board in millimetres
- a = horizontal span of the board, i.e. distance between uprights in metres
- h = head of grain to the bottom of the division in metres
- p = total load per unit length derived from the tables in newtons
- k = factor dependent upon vertical distribution of the loading.

When the vertical distribution of the loading is assumed to be uniform, i.e. rectangular, k shall be taken as equal to 1.0. For a trapezoidal distribution

$$k = 1.0 + 0.06 (50 - R)$$

Where:

R is the upper end bearing reaction taken from table A 13-5 or A 13-6.

.5 Stays or shores

The sizes of stays and shores shall be so determined that the loads derived from tables A 13-1 to A 13-4 inclusive shall not exceed one third of the breaking loads.

14 SAUCERS

14.1 For the purpose of reducing the heeling moment a saucer may be used in place of a longitudinal division in way of a hatch opening only in a "filled, trimmed" compartment as defined in A 2.2, except in the case of linseed and other seeds having similar properties, where a saucer may not be substituted for a longitudinal division. If a longitudinal division is provided, it shall meet the requirements of A 10.9.

14.2 The depth of the saucer, measured from the bottom of the saucer to the deck line, shall be as follows:

- .1 For ships with a moulded breadth of up to 9.1 m, not less than 1.2 m.
- .2 For ships with a moulded breadth of 18.3 m or more, not less than 1.8 m.
- .3 For ships with a moulded breadth between 9.1 m and 18.3 m, the minimum depth of the saucer shall be calculated by interpolation.

14.3 The top (mouth) of the saucer shall be formed by the underdeck structure in way of the hatchway, i.e. hatch side girders or coamings and hatch end beams. The saucer and hatchway above shall be completely filled with bagged grain or other suitable cargo laid down on a separation cloth or its equivalent and stowed tightly against adjacent structure so as to have a bearing contact with such structure to a depth equal to or greater than one half of the depth specified in A 14.2. If hull structure to provide such bearing surface is not available, the saucer shall be fixed in position by steel wire rope, chain, or double steel strapping as specified in A 17.1.4 and spaced not more than 2.4 m apart.

15 BUNDLING OF BULK

As an alternative to filling the saucer in a "filled, trimmed" compartment with bagged grain or other suitable cargo a bundle of bulk grain may be used provided that:

- .1 The dimensions and means for securing the bundle in place are the same as specified for a saucer in A 14.2 and A 14.3.
- .2 The saucer is lined with a material acceptable to the Administration having a tensile strength of not less than 2,687 N per 5 cm strip and which is provided with suitable means for securing at the top.
- .3 As an alternative to A 15.2, a material acceptable to the Administration having a tensile strength of not less than 1,344 N per 5 cm strip may be used if the saucer is constructed as follows:
 - .3.1 Athwartship lashings acceptable to the Administration shall be placed inside the saucer formed in the bulk grain at intervals of not more than 2.4 m. These lashings shall be of sufficient length to permit being drawn up tight and secured at the top of the saucer.
 - .3.2 Dunnage not less than 25 mm in thickness or other suitable material of equal strength and between 150 mm and 300 mm in width shall be placed fore and aft over these lashings to prevent the cutting or chafing of the material which shall be placed thereon to line the saucer.
- .4 The saucer shall be filled with bulk grain and secured at the top except that when using material approved under A 15.3 further dunnage shall be laid on top after lapping the material before the saucer is secured by setting up the lashings.
- .5 If more than one sheet of material is used to line the saucer they shall be joined at the bottom either by sewing or by a double lap.
- .6 The top of the saucer shall be coincidental with the bottom of the beams when these are in place and suitable general cargo or bulk grain may be placed between the beams on top of the saucer.

MSC 59/33

ANNEX 35

Page 18

16 OVERSTOWING ARRANGEMENTS

16.1 Where bagged grain or other suitable cargo is utilized for the purpose of securing "partly filled" compartments, the free grain surface shall be level and shall be covered with a separation cloth or equivalent or by a suitable platform. Such platform shall consist of bearers spaced not more than 1.2 m apart and 25 mm boards laid thereon spaced not more than 100 mm apart. Platforms may be constructed of other materials provided they are deemed by the Administration to be equivalent.

16.2 The platform or separation cloth shall be topped off with bagged grain tightly stowed and extending to a height of not less than one sixteenth of the maximum breadth of the free grain surface or 1.2 m, whichever is the greater.

16.3 The bagged grain shall be carried in sound bags which shall be well filled and securely closed.

16.4 Instead of bagged grain, other suitable cargo tightly stowed and exerting at least the same pressure as bagged grain stowed in accordance with A 16.2 may be used.

17 STRAPPING OR LASHING

When, in order to eliminate heeling moments in partly filled compartments, strapping or lashing is utilized, the securing shall be accomplished as follows:

- .1 The grain shall be trimmed and levelled to the extent that it is very slightly crowned and covered with burlap separation cloths, tarpaulins or the equivalent.
- .2 The separation cloths and/or tarpaulins shall overlap by at least 1.8 m.
- .3 Two solid floors of rough 25 mm by 150 mm to 300 mm lumber shall be laid with the top floor running longitudinally and nailed to an athwartships bottom floor. Alternatively, one solid floor of 50 mm lumber, running longitudinally and nailed over the top of a 50 mm bottom bearer not less than 150 mm wide, may be used. The bottom bearers shall extend the full breadth of the compartment and shall be spaced not more than 2.4 m apart. Arrangements utilizing other materials and deemed by the Administration to be equivalent to the foregoing may be accepted.
- .4 Steel wire rope (19 mm diameter or equivalent), double steel strapping (50 mm x 1.3 mm and having a breaking load of at least 49 kN), or chain of equivalent strength, each of which shall be set tightly by means of a 32 mm turnbuckle, may be used for lashings. A winch tightener, used in conjunction with a locking arm, may be substituted for the 32 mm turnbuckle when steel strapping is used, provided suitable wrenches are available for setting up as necessary. When steel strapping is used, not less than three crimp seals shall be used for securing the ends. When wire is used, not less than four clips shall be used for forming eyes in the lashings.

- .5 Prior to the completion of loading the lashing shall be positively attached to the framing at a point approximately 450 mm below the anticipated final grain surface by means of either a 25 mm shackle or beam clamp of equivalent strength.
- .6 The lashings shall be spaced not more than 2.4 m apart and each shall be supported by a bearer nailed over the top of the fore and aft floor. This bearer shall consist of lumber of not less than 25 mm by 150 mm or its equivalent and shall extend the full breadth of the compartment.
- .7 During the voyage the strapping shall be regularly inspected and set up where necessary.

18 SECURING WITH WIRE MESH

When, in order to eliminate grain heeling moments in "partly filled" compartments, strapping or lashing is utilized, the securing may, as an alternative to the method described in A 17, be accomplished as follows:

- .1 The grain shall be trimmed and levelled to the extent that it is very slightly crowned along the fore and aft centreline of the compartment.
- .2 The entire surface of the grain shall be covered with burlap separation cloths, tarpaulins, or the equivalent. The covering material shall have a tensile strength of not less than 1,344 N per 5 cm strip.
- .3 Two layers of wire reinforcement mesh shall be laid on top of the burlap or other covering. The bottom layer is to be laid athwartships and the top layer is to be laid longitudinally. The lengths of wire mesh are to be overlapped at least 75 mm. The top layer of mesh is to be positioned over the bottom layer in such a manner that the squares formed by the alternate layers measure approximately 75 mm by 75 mm. The wire reinforcement mesh is the type used in reinforced concrete construction. It is fabricated of 3 mm diameter steel wire having a breaking strength of not less than 52 kN/cm², welded in 150 mm x 150 mm squares. Wire mesh having mill scale may be used but mesh having loose, flaking rust may not be used.
- .4 The boundaries of the wire mesh, at the port and starboard side of the compartment, shall be retained by wood planks 150 mm x 50 mm.
- .5 Hold-down lashings, running from side to side across the compartment, shall be spaced not more than 2.4 m apart except that the first and the last lashing shall not be more than 300 mm from the forward or after bulkhead, respectively. Prior to the completion of the loading, each lashing shall be positively attached to the framing at a point approximately 450 mm below the anticipated final grain surface by means of either a 25 mm shackle or beam clamp of equivalent strength. The lashing shall be led from this point over the top of the boundary plank described in A 18.1.4, which has the function of distributing the downward pressure exerted by the lashing. Two layers of 150 mm x 25 mm planks shall be laid athwartships centred beneath each lashing and extending the full breadth of the compartment.

- .6 The hold-down lashings shall consist of steel wire rope (19 mm diameter or equivalent), double steel strapping (50 mm x 1.3 mm and having a breaking load of at least 49 kN), or chain of equivalent strength, each of which shall be set tight by means of a 32 mm turnbuckle. A winch tightener, used in conjunction with a locking arm, may be substituted for the 32 mm turnbuckle when steel strapping is used, provided suitable wrenches are available for setting up as necessary. When steel strapping is used, not less than three crimp seals shall be used for securing the ends. When wire rope is used, not less than four clips shall be used for forming eyes in the lashings.

- .7 During the voyage the hold-down lashings shall be regularly inspected and set up where necessary.

PART B

CALCULATION OF ASSUMED HEELING MOMENTS
 AND GENERAL ASSUMPTIONS

1 GENERAL ASSUMPTIONS

1.1 For the purpose of calculating the adverse heeling moment due to a shift of cargo surface in ships carrying bulk grain it shall be assumed that:

- .1 In filled compartments which have been trimmed in accordance with A 10.2, a void exists under all boundary surfaces having an inclination to the horizontal less than 30° and that the void is parallel to the boundary surface having an average depth calculated according to the formula:

$$Vd = Vd_1 + 0.75 (d - 600) \text{ mm}$$

Where:

Vd = average void depth in millimetres:

Vd₁ = standard void depth from table B 1-1 below:

d = actual girder depth in millimetres.

In no case shall Vd be assumed to be less than 100 mm.

Table B 1-1

Distance from hatch end or hatch side to boundary of compartment	Standard void depth Vd.
metres	millimetres
0.5	570
1.0	530
1.5	500
2.0	480
2.5	450
3.0	440
3.5	430
4.0	430
4.5	430
5.0	430
5.5	450
6.0	470
6.5	490
7.0	520
7.5	550
8.0	590

Notes on table B 1-1:

- (1) For boundary distances greater than 8.0 m the standard void depth (Vd_1) shall be linearly extrapolated at 80 mm increase for each 1.0 m increase in length.
 - (2) In the corner area of a compartment the boundary distance shall be the perpendicular distance from the line of the hatch side girder or the line of the hatch end beam to the boundary of the compartment, whichever is the greater. The girder depth (d) shall be taken to be the depth of the hatch side girder or the hatch end beam, whichever is the less.
 - (3) Where there is a raised deck clear of the hatchway the average void depth measured from the underside of the raised deck shall be calculated using the standard void depth in association with a girder depth of the hatch end beam plus the height of the raised deck.
- .2 Within filled hatchways and in addition to any open void within the hatch cover there is a void of average depth of 150 mm measured down to the grain surface from the lowest part of the hatch cover or the top of the hatch side coaming, whichever is the lower.
 - .3 In a "filled compartment, untrimmed" which is exempted from trimming outside the periphery of the hatchway by the provisions of A 10.3.1, it shall be assumed that the surface of the grain after loading will slope into the void space underdeck, in all directions, at an angle of 30° to the horizontal from the edge of the opening which establishes the void.
 - .4 In a "filled compartment, untrimmed" which is exempted from trimming in the ends of the compartment under the provisions of A 10.3.2, it shall be assumed that the surface of the grain after loading will slope in all directions away from the filling area at an angle of 30° from the lower edge of the hatch end beam. However, if feeding holes are provided in the hatch end beams in accordance with table B 1-2, then the surface of the grain after loading shall be assumed to slope in all directions, at an angle of 30° from a line on the hatch end beam which is the mean of the peaks and valleys of the actual grain surface as shown in figure B 1.

Table B 1-2

Diameter (mm) Minimum	Area (cm ²)	Spacing (metres) Maximum
90	63.6	.60
100	78.5	.75
110	95.0	.90
120	113.1	1.07
130	133.0	1.25
140	154.0	1.45
150	177.0	1.67
160	201.0	1.90
170 or above	227.0	2.00 maximum

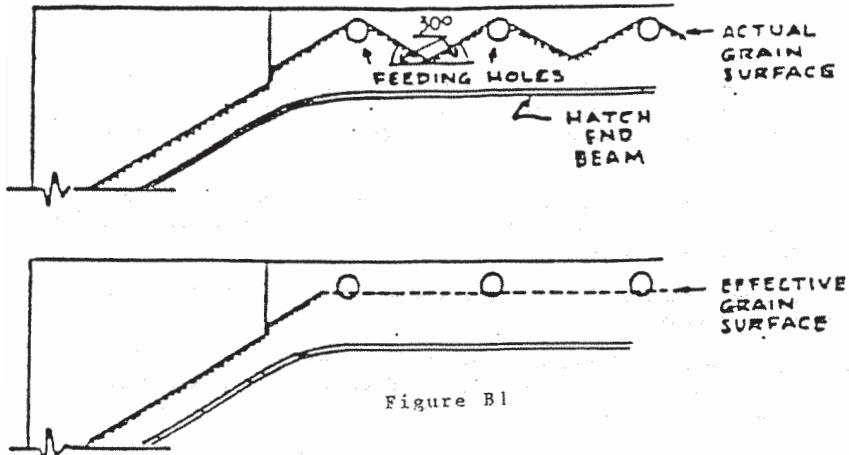

1.2 The description of the pattern of grain surface behaviour to be assumed in partly filled compartments is contained in B 5.

1.3 For the purpose of demonstrating compliance with the stability criteria in A 7, the ship's stability calculations shall normally be based upon the assumption that the centre of gravity of cargo in a "filled compartment, trimmed" is at the volumetric centre of the whole cargo space. In those cases where the Administration authorizes account to be taken of the effect of assumed underdeck voids on the vertical position of the centre of gravity of the cargo in "filled compartments, trimmed" it will be necessary to compensate for the adverse effect of the vertical shift of grain surfaces by increasing the assumed heeling moment due to the transverse shift of grain as follows:

$$\text{total heeling moment} = 1.06 \times \text{calculated transverse heeling moment.}$$

In all cases the weight of cargo in a "filled compartment, trimmed" shall be the volume of the whole cargo space divided by the stowage factor.

1.4 The centre of gravity of cargo in a "filled compartment, untrimmed" shall be taken to be the volumetric centre of the whole cargo compartment with no account being allowed for voids. In all cases the weight of cargo shall be the volume of the cargo (resulting from the assumptions stated in B 1.1.3 or B 1.1.4) divided by the stowage factor.

1.5 In partly filled compartments the adverse effect of the vertical shift of grain surfaces shall be taken into account as follows:

$$\text{total heeling moment} = 1.12 \times \text{calculated transverse heeling moment.}$$

1.6 Any other equally effective method may be adopted to make the compensation required in B 1.3 and B 1.5.

MSC 59/33
ANNEX 35
Page 24

2 ASSUMED VOLUMETRIC HEELING MOMENT OF A FILLED COMPARTMENT, TRIMMED

General

2.1 The pattern of grain surface movement relates to a transverse section across the portion of the compartment being considered and the resultant heeling moment should be multiplied by the length to obtain the total moment for that portion.

2.2 The assumed transverse heeling moment due to grain shifting is a consequence of final changes of shape and position of voids after grain has moved from the high side to the low side.

2.3 The resulting grain surface after shifting shall be assumed to be at 15° to the horizontal.

2.4 In calculating the maximum void area that can be formed against a longitudinal structural member, the effects of any horizontal surfaces, e.g. flanges or face bars, shall be ignored.

2.5 The total areas of the initial and final voids shall be equal.

2.6 Longitudinal structural members which are grain-tight may be considered effective over their full depth except where they are provided as a device to reduce the adverse effect of grain shift, in which case the provisions of A 10.9 shall apply.

2.7 A discontinuous longitudinal division may be considered effective over its full length.

Assumptions

In the following paragraphs it is assumed that the total heeling moment for a compartment is obtained by adding the results of separate consideration of the following portions:

2.8 Before and abaft hatchways:

- .1 If a compartment has two or more main hatchways through which loading may take place, the depth of the underdeck void for the portion or portions between such hatchways shall be determined using the fore and aft distance to the midpoint between the hatchways.

- .2 After the assumed shift of grain the final void pattern shall be as shown in figure B 2-1.

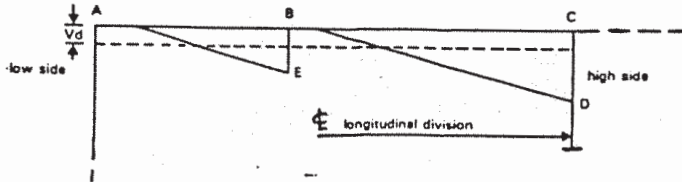

Figure B 2-1

Notes on figure B 2-1

- (1) If the maximum void area which can be formed against the girder at B is less than the initial area of the void under AB, i.e. $AB \times V_d$, the excess area shall be assumed to transfer to the final void on the high side.
- (2) If, for example, the longitudinal division at C is one which has been provided in accordance with A 10.9, it shall extend to at least 0.6 m below D or E whichever gives the greater depth.

2.9.

- .1 In and abreast of hatchways without longitudinal division:

After the assumed shift of grain the final void pattern shall be as shown in figure B 2-2 or figure B 2-3:

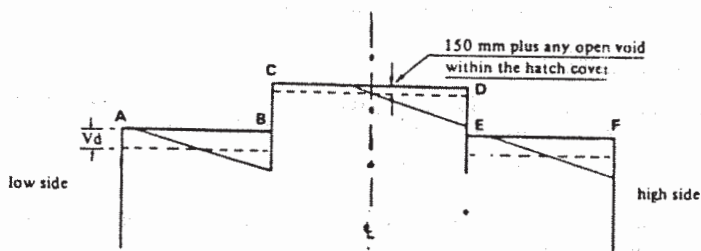

Figure B 2-2

Notes on figure B 2-2:

- (1) AB Any area in excess of that which can be formed against the girder at B shall transfer to the final void area in the hatchway.
- (2) CD Any area in excess of that which can be formed against the girder at E shall transfer to the final void area on the high side.

.2 In and abreast of hatchways with longitudinal division:

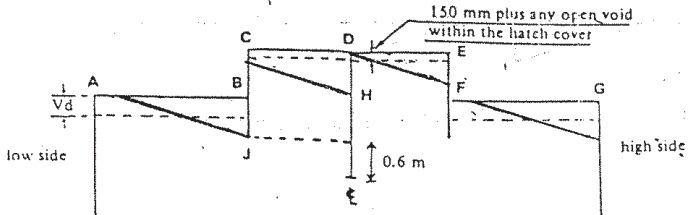

Figure B 2-3

Notes on figure B 2-3:

- (1) The excess void area from AB shall transfer to the low side half of the hatchway in which two separate final void areas will be formed viz. one against the centreline division and the other against the hatch side coaming and girder on the high side.
- (2) If a bagged saucer or bulk bundle is formed in a hatchway it shall be assumed for the purpose of calculating the transverse heeling moment that such a device is at least equivalent to the centreline division.
- (3) If the centreline division is one which has been provided in accordance with A 10.9, it shall extend to at least 0.6 m below H or J whichever gives the greater depth.

Compartments loaded in combination

The following paragraphs describe the pattern of void behaviour which shall be assumed when compartments are loaded in combination:

2.10 Without effective centreline divisions:

- .1 Under the upper deck - as for the single deck arrangement described in B 2.8.2 and B 2.9.1.
- .2 Under the second deck - the area of void available for transfer from the low side, i.e. original void area less area against the hatch side girder, shall be assumed to transfer as follows:

one half to the upper deck hatchway and one quarter each to the high side under the upper and second deck.
- .3 Under the third and lower decks - the void areas available for transfer from the low side of each of these decks shall be assumed to transfer in equal quantities to all the voids under the decks on the high side and the void in the upper deck hatchway.

2.11 With effective centreline divisions which extend into the upper deck hatchway:

- .1 At all deck levels abreast of the division the void areas available for transfer from the low side shall be assumed to transfer to the void under the low side half of the upper deck hatchway.
- .2 At the deck level immediately below the bottom of the division the void area available for transfer from the low side shall be assumed to transfer as follows:

one half to the void under the low side half of the upper deck hatchway and the remainder in equal quantities to the voids under the decks on the high side.
- .3 At deck levels lower than those described in B 2.11.1 or B 2.11.2, the void area available for transfer from the low side of each of those decks shall be assumed to transfer in equal quantities to the voids in each of the two halves of the upper deck hatchway on each side of the division and the voids under the decks on the high side.

2.12 With effective centreline divisions which do not extend into the upper deck hatchway:

Since no horizontal transfer of voids may be assumed to take place at the same deck level as the division, the void area available for transfer from the low side at this level shall be assumed to transfer above the division to voids on the high side in accordance with the principles of B 2.10 and B 2.11.

3 ASSUMED VOLUMETRIC HEELING MOMENT OF A FILLED COMPARTMENT, UNTRIMMED

3.1 All the provision for "filled compartments, trimmed" set forth in B 2 shall also apply to "filled compartments, untrimmed" except as noted below.

3.2 In "filled compartments, untrimmed" which are exempted from trimming outside the periphery of the hatchway under the provisions of A 10.3.1:

- .1 the resulting grain surface after shifting shall be assumed to be at an angle of 25° to the horizontal. However, if in any section of the compartment, forward, aft, or abreast of the hatchway the mean transverse area of the void in that section is equal to or less than the area which would obtain by application of B 1.1, then the angle of grain surface after shifting in that section shall be assumed to be 15° to the horizontal; and
- .2 the void area at any transverse section of the compartment shall be assumed to be the same both before and after the grain shift, i.e. it shall be assumed that additional feeding does not occur at the time of the grain shift.

3.3 In "filled compartments, untrimmed" which are exempted from trimming in the ends, forward and aft of the hatchway, under the provisions of A 10.3.2:

- .1 the resulting grain surface abreast of the hatchway after shifting shall be assumed to be at an angle of 15° to the horizontal; and
- .2 the resulting grain surface in the ends, forward and aft of the hatchway after shifting shall be assumed to be at an angle of 25° to the horizontal.

4 ASSUMED VOLUMETRIC HEELING MOMENTS IN TRUNKS

After the assumed shift of grain the final void pattern shall be as shown in figure B 4:

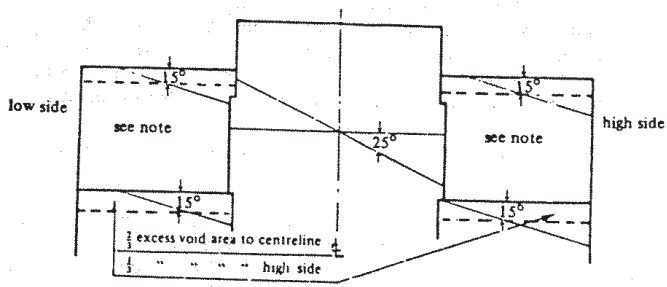

Figure B 4

Note on figure B 4:

If the wing spaces in way of the trunk cannot be properly trimmed in accordance with A 10, it shall be assumed that a 25° surface shift takes place.

5 ASSUMED VOLUMETRIC HEELING MOMENT OF A PARTLY FILLED COMPARTMENT

5.1 When the free surface of the bulk grain has not been secured in accordance with A 16, A 17 or A 18, it shall be assumed that the grain surface after shifting shall be at 25° to the horizontal.

5.2 In a partly filled compartment, a division, if fitted, shall extend from one eighth of the maximum breadth of the compartment above the level of the grain surface and to the same distance below the grain surface.

MSC 59/33
ANNEX 35
Page 29

5.3 In a compartment in which the longitudinal divisions are not continuous between the transverse boundaries, the length over which any such divisions are effective as devices to prevent full width shifts of grain surfaces shall be taken to be the actual length of the portion of the division under consideration less two sevenths of the greater of the transverse distances between the division and its adjacent division or ship's side. This correction does not apply in the lower compartments of any combination loading in which the upper compartment is either a filled compartment or a partly filled compartment.

6 OTHER ASSUMPTIONS

An Administration or a Contracting Government on behalf of an Administration may authorize departure from the assumptions contained in this Code in those cases where it considers this to be justified having regard to the provisions for loading or the structural arrangements provided the stability criteria in A 7 are met. Where such authorization is granted under this regulation, particulars shall be included in the document of authorization or grain loading data.
